

# HARKEN®

## MKIV JIB REEFING & FURLING

### Unit 0

Installation Manual – Intended for specialized personnel or expert users

4416 v2.06/23



#### Preassembly

Safety Precautions/Parts Descriptions	2
Sizing Check	3
Parts	4
Rigging Parts Check/Tools	5
Dimensions/Sailmaker's Instructions	6
Toggle Deductions/Stay Into Foil Options	7
Top Foil Length	8
Short Top Foil	9
Confirm Foil Length	10

#### Assembly

Foils/Connectors	11–17
Halyard Swivel	17
Drum Assembly	18
Rod Rigging	19
Turnbuckle/Toggle	20
Final/Feeder	21–22

#### Commissioning

Turnbuckle	23
Line to Cockpit	24
Halyard Wrap/Prevent Halyard Wrap	25
Pendant/Halyard Restrainer/ Halyard Tension	26

#### Operation

Spinnaker Halyards/Headstay Tension	27
Raise Sails	28
Furl/Reef	28–29
Secure Sail	29
Race Conversion	30

#### Maintenance

Clean/Inspect	31
Replace Line	31
Storage/Remove Furler	31

#### Troubleshooting 32

#### Warranty 32

#### Appendix 33–34

Please read these instructions carefully before installing, servicing, or operating the equipment. This manual may be modified without notice. See: [www.harken.com/manuals](http://www.harken.com/manuals) for updated versions.

PLEASE SAVE THESE INSTRUCTIONS

## Introduction

This manual gives technical information on installation and service. This information is **destined exclusively** for specialized personnel or expert users. Installation, disassembling, and reassembling by personnel who are not experts may cause serious damage to property or injury to users and those in the vicinity of the product. If you do not understand an instruction contact Harken.

The user must have appropriate training in order to use this product.

Harken accepts no responsibility for damage or harm caused by not observing the safety requirements and instructions in this manual. See limited warranty, general warnings, and instructions in [www.harken.com/manuals](http://www.harken.com/manuals).

## Purpose

Harken® Jib Reefing and Furling is designed for rolling sails on sailboats to reduce sail size or to completely roll so wind has little effect on the sail. Use of this product for other than normal sailboat applications is not covered by the limited warranty.

## Safety Precautions



**WARNING!** This symbol alerts you to potential hazards that may result in death or serious injury if instructions are not followed. The message gives guidance on how to reduce the chance of injury. Strictly follow all instructions to avoid potential hazards that can result in death or serious injury. See [www.harken.com/manuals](http://www.harken.com/manuals) for general warnings and instructions.



**CAUTION!** This symbol alerts you to potential hazards that may result in serious injury if these instructions are not followed. The message gives guidance on how to reduce the chance of injury.

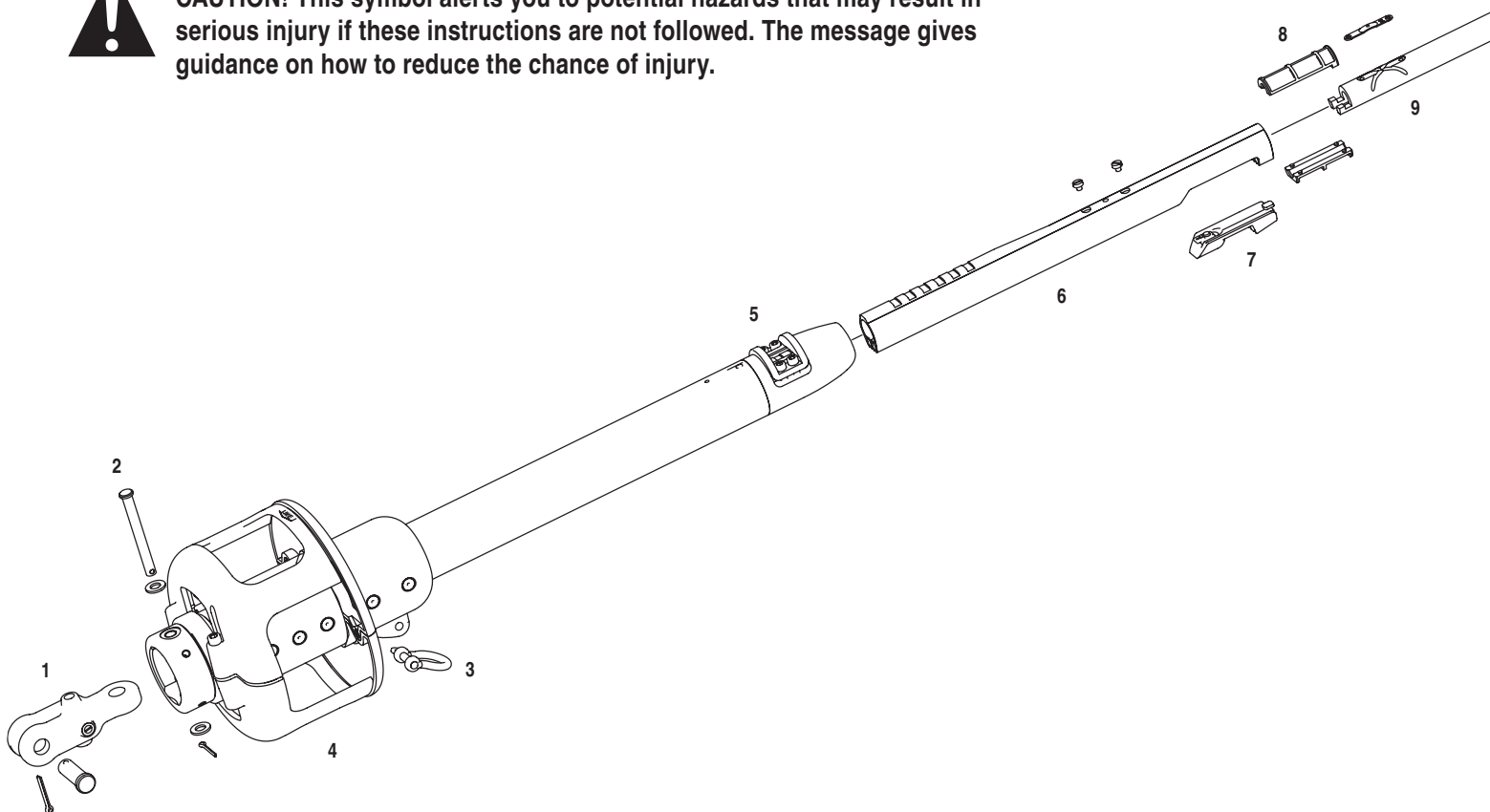

## Parts Descriptions

- |                  |                            |                      |                     |
|------------------|----------------------------|----------------------|---------------------|
| 1) Toggle        | 5) Foil Clamp              | 9) Bottom Connector  | 13) Connector       |
| 2) Pin           | 6) 2' (610 mm) Bottom Foil | 10) 7' (2.13 m) Foil | 14) Halyard Swivel  |
| 3) Shackle       | 7) Feeder                  | 11) Connector Screws | 15) Trim Cap        |
| 4) Drum Assembly | 8) Connector Bushing       | 12) Connector Wedge  | 16) Trim Cap Screws |

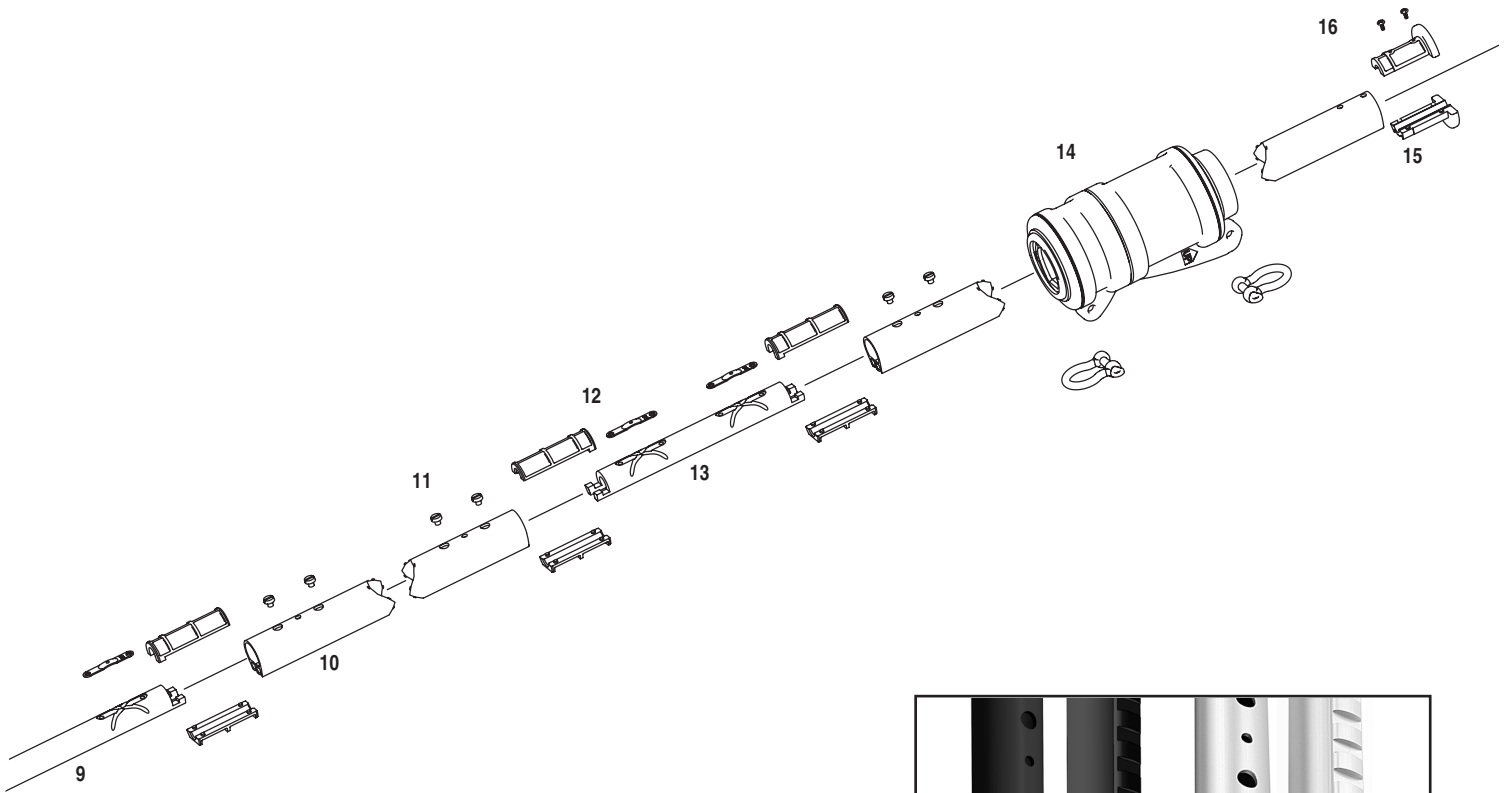

### Size Check

1. Check headstay and clevis pin dimensions in chart below.



**WARNING!** Do not drill boat's chainplate or toggle. This may result in rig failure. Use the correct size toggle and clevis pin.

2. Harken does not recommend drilling boat's chainplate or toggle. In some cases bushings are available to fit boats with smaller clevis pin sizes.
3. Will drum fit on bow? See Page 6. If necessary, use an additional toggle to slightly raise unit.

Sizing Check			
Unit Part No.	Description	Wire Sizes	
7410.10	MKIV Unit 0 <b>Note: Black foils standard.</b> <b>Silver foils available.</b>	3/16", 7/32"	5 mm, 6 mm
		Rod Sizes	
		-4, -6	4.37 mm, 5.03 mm
Toggle Part No.	Description	Chainplate Clevis Pin Size	
7410.20 5/16	Eye/jaw reversible	5/16"	7.9 mm
7410.20 3/8	Eye/jaw reversible	3/8"	9.5 mm
7410.20 7/16	Eye/jaw reversible	7/16"	11.1 mm

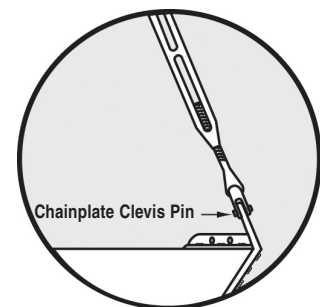



**Main Components**

Part No.	Quantity	Description
HFG290	1	Drum assembly with foil clamp
H-39923	1	Halyard swivel

**Foils (Standard Package)**

Part No.	Quantity	Description
7410.30.BLACK	5	7' (2.13 m) Foils, black anodized
7410.33.BLACK	1	2' (610 mm) Bottom foil, back anodized

**Foils (Special Order)**

Part No.	Quantity	Description
7410.30.CLEAR	5	7' (2.13 m) Foil
7410.33.CLEAR	1	2' (610 mm) Bottom foil

**Line (Standard Package)**

Part No.	Quantity	Description
HFG594	55' (16.7 m)	7 mm double braid polyester

**Tools**

Quantity	Description
1 Each	2.5, 3, 5 mm Hex keys

**Other Components**

Part No.	Quantity	Description
7410.31	4	6.5" (165 mm) Connector
7410.32	1	10" (254 mm) Bottom Connector
HFG294	1	Connector bushing set (10-H-42067/10-H-42068)
HFG298	1	Plastic connector wedge set (12-H-39625)
HFG341	1	Foil screw set (26-HFS1105)
HFG679	1	Trim cap set (H-37335/H-37336)
HFG629	1	Trim cap screw set (3-HFS1126)
947	1	Prefeeder
H-39713	1	Feeder with screw and tab
2110	3	6 mm Bow shackle
HFG739	2	Red Loctite® (for foil screws)
HFG725	1	Injector, 1 oz. 5200 Adhesive (HFG722)

1. Harken toggle assembly required. Sold separately.
2. Mating turnbuckle components must be purchased separately.
3. Headstay may require cutting and shortening to fit Harken toggle. Headstay may remain uncut by replacing lower stud of turnbuckle with stud/eye thus eliminating extra toggle.
4. Rod rigging requires Harken rod adapter stud.
5. Order Harken 7404 Lead Block Kit. Fits 1" (25 mm) stanchions.



**WARNING!** A stay that is old or damaged may break suddenly, causing an accident. Headstay condition should be checked by a professional rigger before reusing.

**ALL UNITS  
Harken Toggle  
(Sold Separately)**



7410.20 5/16  
7410.20 3/8  
7410.20 7/16  
Eye/Jaw Toggle

**ROD RIGGING  
Harken Rod Adapter  
Stud Required  
(Sold Separately)**



7420 -4  
7421 -6  
Rod Adapter Stud

**7404 Lead Block Kit  
(Sold Separately)**



Includes 3 x 7403; 1 x 7401;  
1 x 7402; 1 Horn Cleat

**Tools Required**



1. Long tape measure	6. Side cutters	11. Center punch
2. Short tape measure	7. Rat-tail file	12. Rigging or black tape
3. Power drill	8. Hex keys (provided)	13. Scissors
4. Drill bit — 1/8" (3 mm)	9. Slotted/Phillips screwdrivers	14. Metal straight edge
5. Hacksaw	10. Needle-nose pliers	15. Hammer

**Adhesive Alert**

MKIV Furlers are shipped with 3M 5200 adhesive. Use adhesives on dry connectors and foils using the special injection system described in the assembly section. Parts may immediately be exposed to rain. Cure is best at 70°F (22°C) with 50% humidity. Do not apply at temperatures below 40°F (5°C) and above 100°F (38°C).

Although adhesive has not cured it will remain in place on foil joints whether they are left on the ground or raised up on boat. Foils can be raised immediately after assembly and sails fitted.

**Note:** A small amount of adhesive may bulge out of injection ports. If possible let system sit for a couple days before sailing. If adhesive gets on sails remove using acetone. For faster-curing adhesive, purchase 4200 Fast Cure.

**Note:** Damaged foils can be repaired. Use a hand-held propane torch to heat joints until foils can be pulled apart.

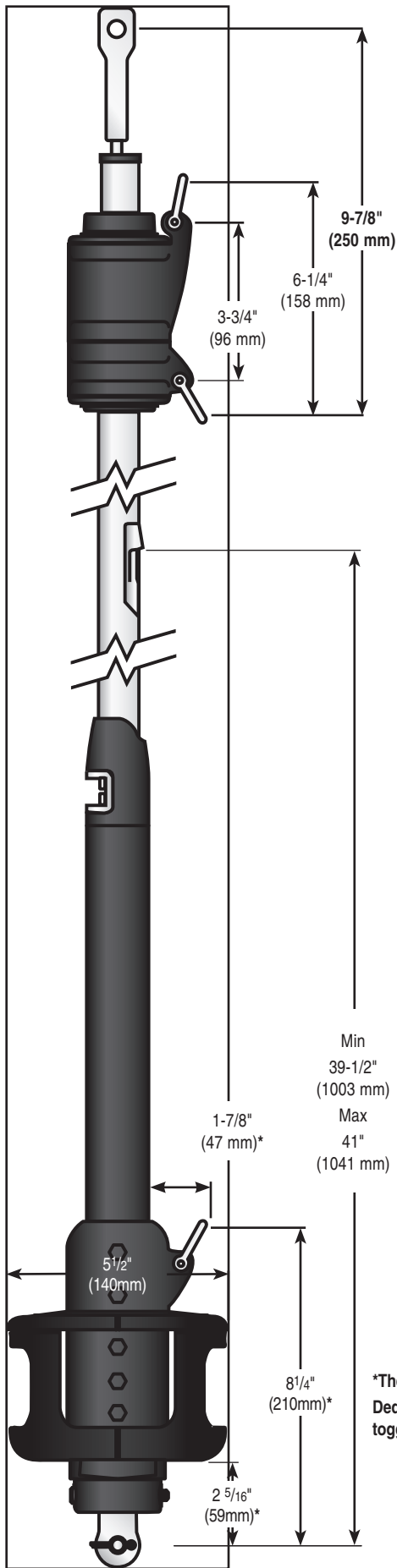

### Luff Length

Note offsets above and below the sail.

A shorter luff may be required if a halyard restrainer is necessary (page 26) or a toggle or long toggle assembly is used to raise drum.

If the luff of sail is not long enough to put the halyard swivel near the top of the headstay foil, a pendant must be added (see page 26).

### Tack Setback

Note setback for the tack shackle and cut the sail accordingly.

### Luff Tape Size

Unit 0 requires #6 (6/32" or 5 mm) luff tape.

### Luff Tape Length

Cut off top of luff tape so it is 18" to 24" (450 to 600 mm) below head of sail. This allows head to lag behind rest of sail to help flatten sail. It will also help head to roll more smoothly.

Note feeder height and extend the bottom of the luff tape downwards so it is below the feeder. This will prevent the luff tape from catching in the feeder as the sail is lowered.

### Tack and Head Shackles

Make sure tack and head shackles fit the sail rings. The minimum inside dimensions of the standard head and tack shackles are:

(A) 1-1/16" (27 mm)

(B) 1/2" (13 mm)

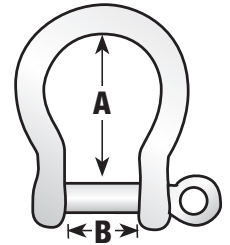

### Sun Cover

Sun cover may be installed on either side of the sail. However, make sure you match other sails in the customer's inventory.

Min  
39-1/2"  
(1003 mm)  
Max  
41"  
(1041 mm)

1-7/8"  
(47 mm)\*

5 1/2"  
(140mm)

8 1/4"  
(210mm)\*

2 5/16"  
(59mm)\*

\*These three dimensions are for the 7/16" (11.1 mm) toggle.  
Deduct 5/16" (8 mm) from these dimensions for smaller  
toggles: 5/16" (7.9 mm) or 3/8" (9.5 mm)

Use dimensions of Harken toggle below to build stay to correct length.

**Tip:** Turnbuckles should be 1/2 to 2/3 open to allow shortening for new wire stretch and for fine-tuning mast rake.

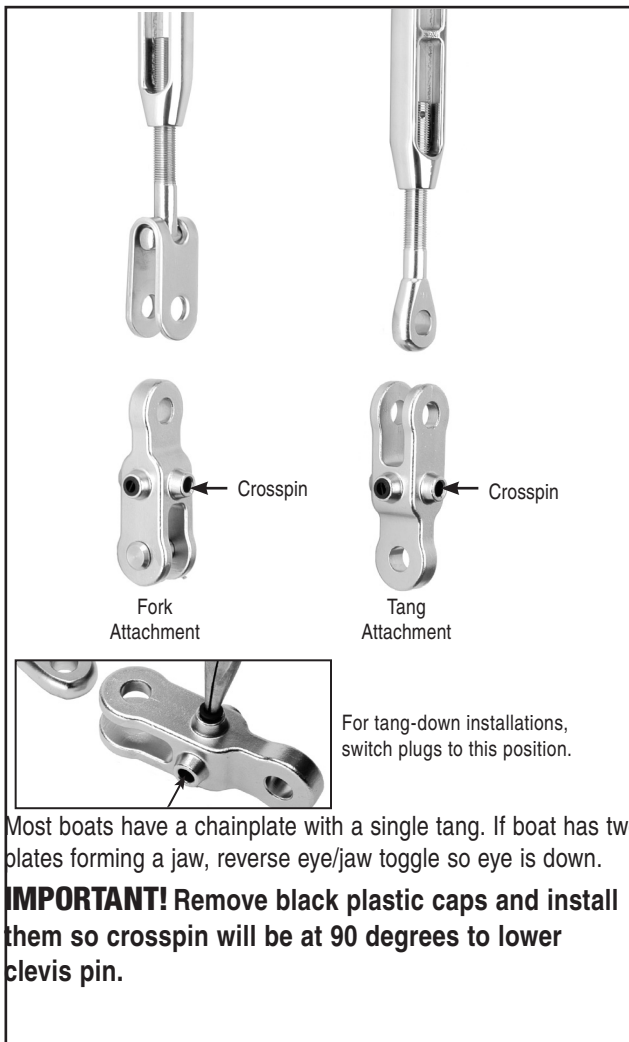

Most boats have a chainplate with a single tang. If boat has two plates forming a jaw, reverse eye/jaw toggle so eye is down.

**IMPORTANT!** Remove black plastic caps and install them so crosspin will be at 90 degrees to lower clevis pin.

Options for Snaking Stay into Foils

1. Swage stud at end of wire.
2. Open end of wire and install Norseman or Sta-Lok® stud after foil is assembled.
3. Rod adapter nosepiece for Harken rod adapter stud: Threaded nosepiece must have a positive lock as well as adhesive. Use Harken stud with cotter pins (see page 19).



**WARNING!** Using a threaded nosepiece with only adhesive at the upper rod eye terminal may result in headstay system failure. Make sure there is a mechanical lock.



Measure A and add to this chart and length chart below		
	Inches	mm
A		
B	.4	10
E*	24.0	610
F	16.25	413
G		
<b>Total A+B+E+F+G</b>		

Make sure upper measurement points of A and pin-to-pin are the same.

Alternate Measurement Point

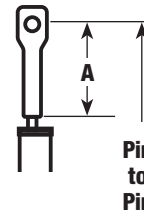

**TOP FOIL LENGTH WORKSHEET**

1	Pin-to-Pin Length	
2	Subtract ABEFG	-
3	<b>Result (Pin-to-Pin — ABEFG)</b>	
4	Subtract D	-
To find "D" pick number from chart below that is closest to, but not greater than total from step 3.		
	<b>Inches</b>	<b>mm</b>
	3 X 84 = 252	3 x 2133.6 = 6400.8
	4 X 84 = 336	4 x 2133.6 = 8534.4
	5 x 84 = 420	5 x 2133.6 = 10668
	6 x 84 = 504	6 x 2133.6 = 12801.6
<b>Example—If result from Step 3 is:</b>		
500 inches "D" = 420 inches    12,000 mm "D" = 10668 mm		
5	<b>Result (C) Top Foil Length</b>	

\*Add 1" (25 mm) if halyard deflector is used (see Page 10).

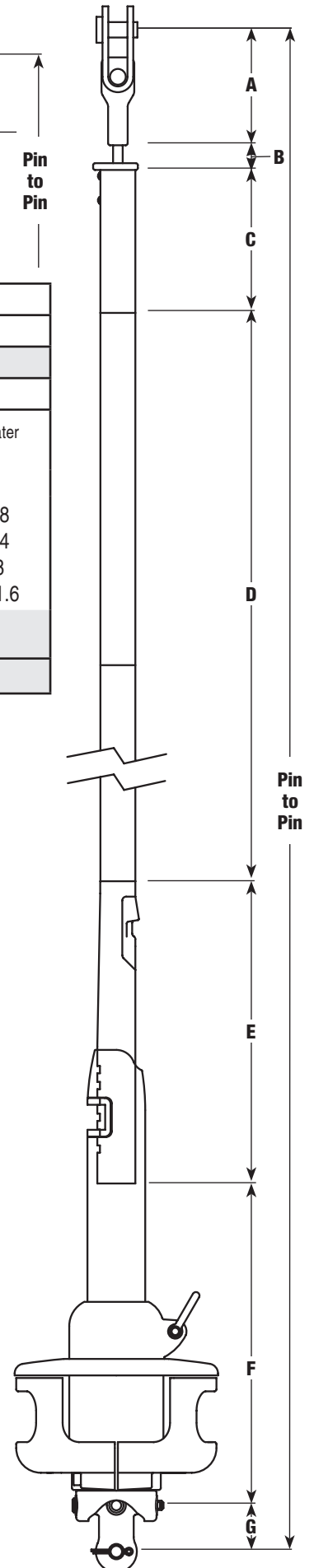

**Length Check**

After completing worksheet above fill in A, C, D, and G below. Add "A" through "G" to confirm total equals your pin-to-pin measurement.

Length Chart		
Dimensions	Inches	mm
A Center of Pin to Bottom of Terminal		
B Bottom of Terminal to Top of Foil	0.4	10
C Top Foil Length		
D Number of Foils _____ x 84" (2133.6 mm)		
E Bottom Foil	24.00	610
F Bottom of Foil to Crosspin	16.25	413
G Crosspin to Clevis Pin		
<b>Pin-to-Pin Length</b>		

G Toggle Distance from Lower Clevis Pin to Crosspin Hole					
Toggle Part No.	Type	Clevis Pin		G Distance	
7410.20 5/16	Eye/Jaw	5/16"	7.9 mm	1.1"	27 mm
7410.20 3/8	Eye/Jaw	3/8"	9.5 mm	1.1"	28 mm
7410.20 7/16	Eye/Jaw	7/16"	11.1 mm	1.4"	37 mm



If top foil is shorter than 7" (177.8 mm), use one of the following special techniques to ensure sufficient bearing surface for the foil in the area of the halyard swivel.

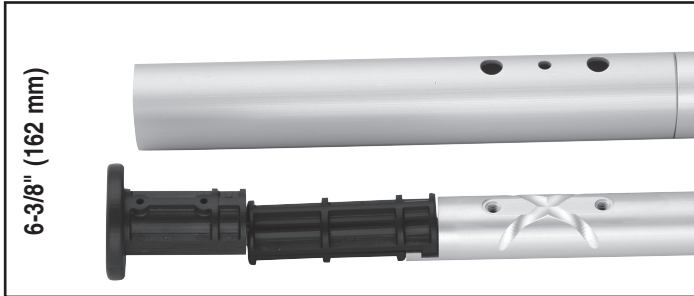

6-3/8" (162 mm) No special treatment required.

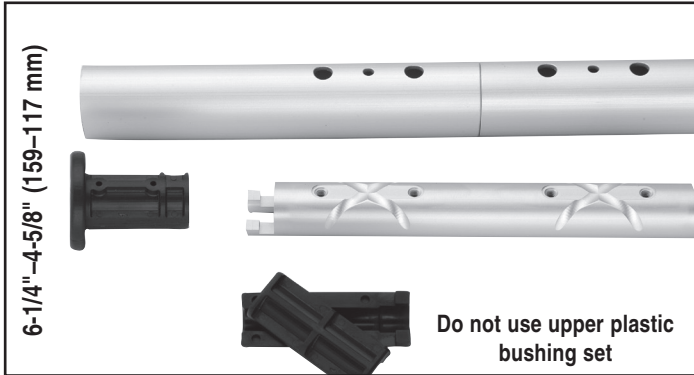

6-1/4"–4-5/8" (159–117 mm) Do not use plastic bushing above top connector. Use plastic bushing below connector.

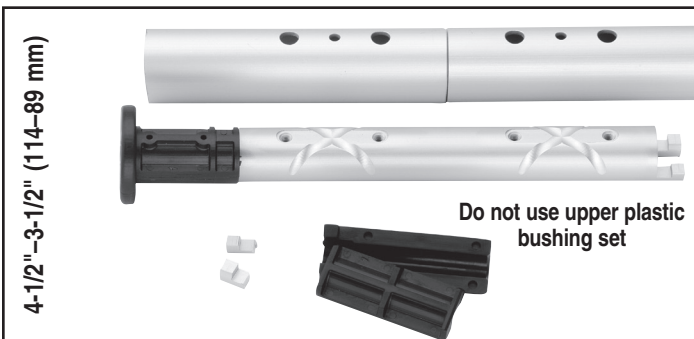

4-1/2"–3-1/2" (114–89 mm) Do not use plastic bushing above top connector. Shorten top of connector and shorten trim cap as needed. Use plastic bushing below connector.

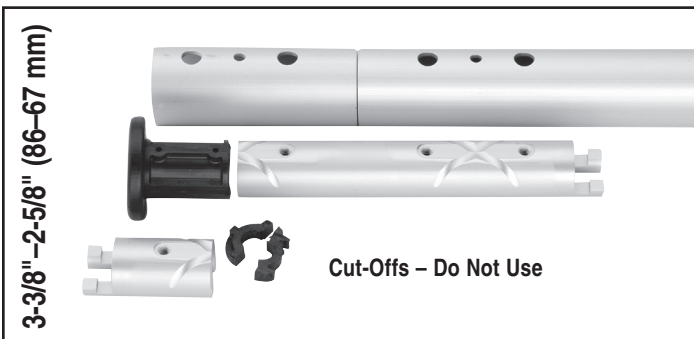

3-3/8"–2-5/8" (86–67 mm) Do not use plastic bushing above top connector. Cut connector right at cross formed by glue dispersion channels. Use single foil screw in top foil only. Use plastic bushing below connector.

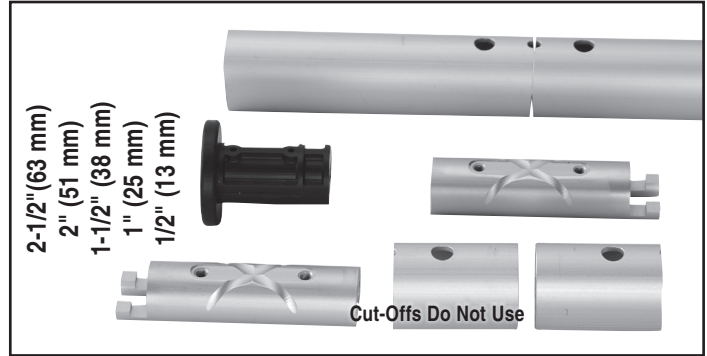

2-1/2"–1/2" (63–13 mm) Shorten top foil and adjoining full length foil so two screws are used to assemble joint instead of four. Do not use plastic bushings above top connector. Use plastic bushing below connector.

Top Foil Length from Worksheet	1. Initial top foil cut length	2. Cut through middle hole in top foil.*  Resulting Top Foil Length	3. Shorten full length adjoining foil by cutting through middle hole.*	4. Shorten connector  Length	5. Shorten trim cap
2-1/2" (63 mm)	5-5/8" (143 mm)	4-1/16" (103 mm)		3-1/4" (83 mm)	No
2" (51 mm)	5-1/8" (130 mm)	3-9/16" (90 mm)		3-1/4" (83 mm)	No
1-1/2" (38 mm)	4-5/8" (117 mm)	3-1/16" (78 mm)		3-1/4" (83 mm)	No
1" (25 mm)	4-1/8" (105 mm)	2-9/16" (65 mm)		3" (76 mm)	Yes
1/2" (13 mm)	3-5/8" (92 mm)	2-1/16" (52 mm)		2-3/4" (70 mm)	Yes

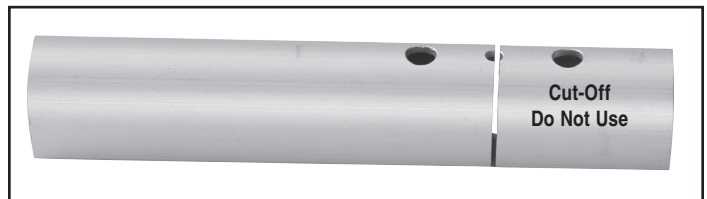

\*To allow for saw cut, position blade so upper half of middle hole is preserved.

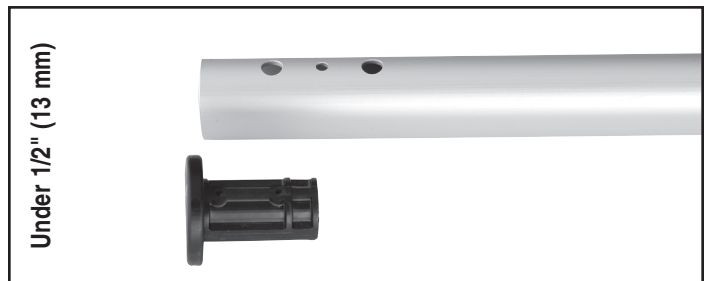

Under 1/2" (13 mm) Eliminate top foil and run foil higher in drum assembly.

Confirm foil length by laying foils alongside stay with turnbuckle components.

Pull stay out so it is straight. Attach Harken toggle to bottom of stay. Make sure toggle straps are straight. Adjust turnbuckle so that length of stay with Harken toggle will fit boat. Ideally turnbuckle will be half to two-thirds open to allow for rig adjustment.

Line up drum assembly so holes below drum line up with holes in Harken toggle. Make sure toggle is tensioned when measuring.

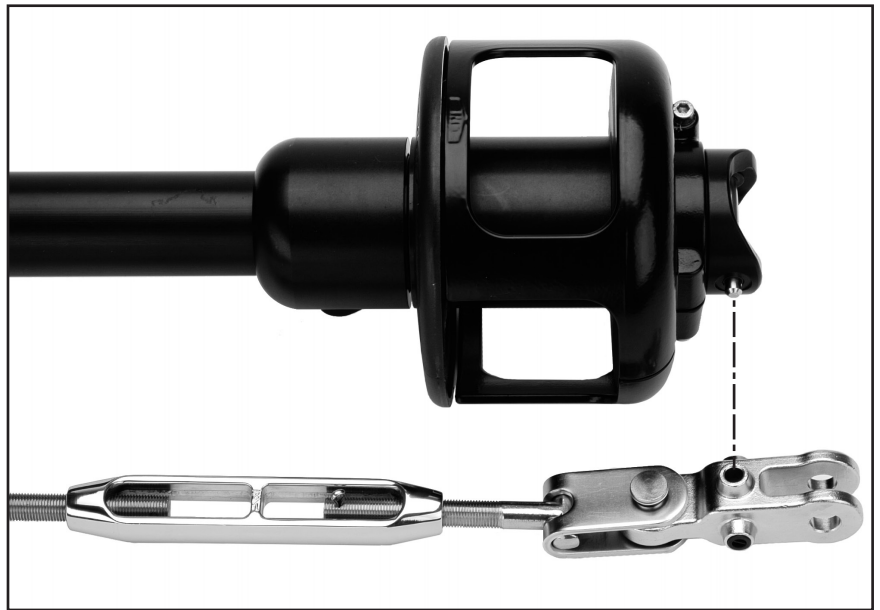

Line up bottom foil so foil clamp is just above or below center of notches in bottom foil.

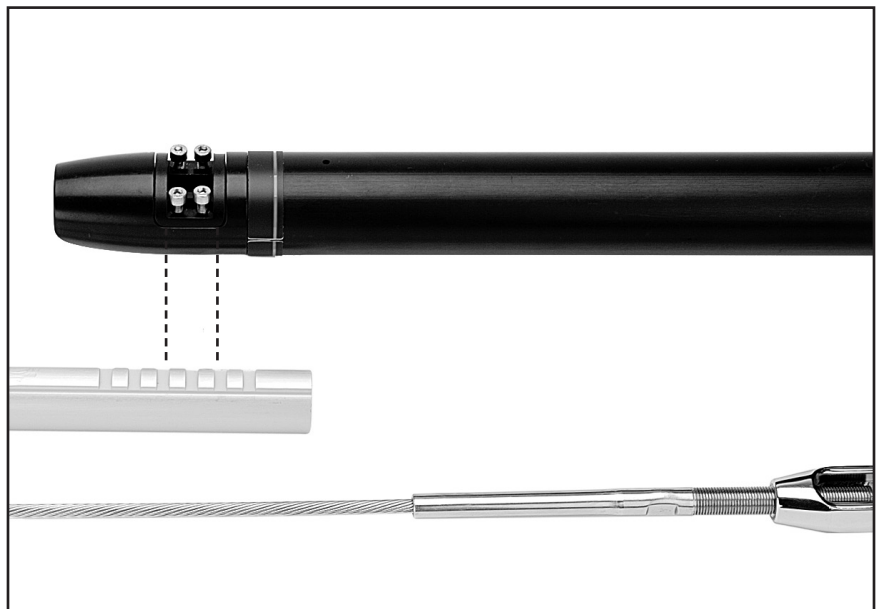

Note: Position top foil so that with top cap the foil will ride 7/16" (11 mm) below terminal. If wire fitting at top of stay is swage, foil must ride just below shoulder of swage. Mark cut line on foil. Wrap tape around foil as a guide so cut is straight.

No halyard deflector — 7/16" (11 mm)

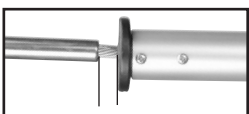

With halyard deflector 1 7/16" (37mm)

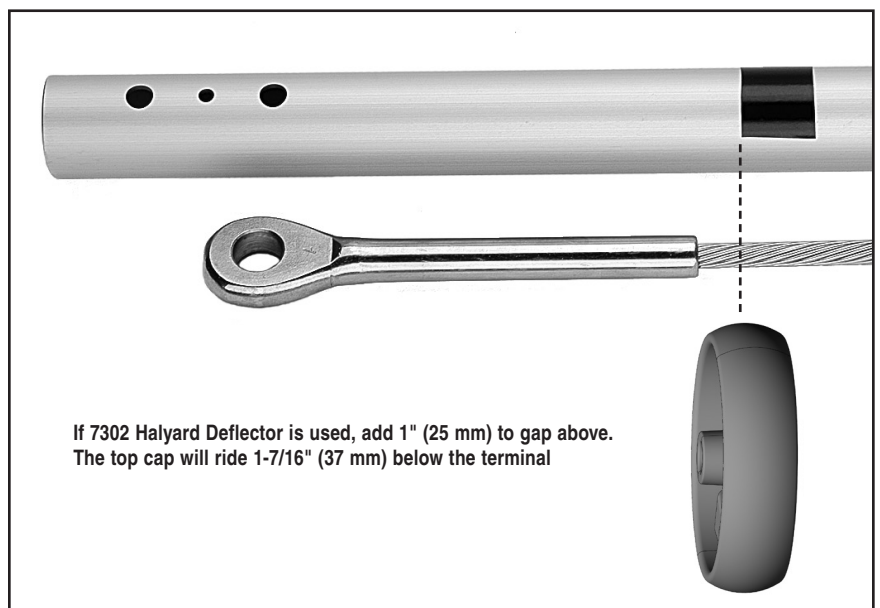
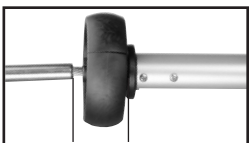

Cut foil to length using a hacksaw.



Deburr inside edge using a rat-tail file.

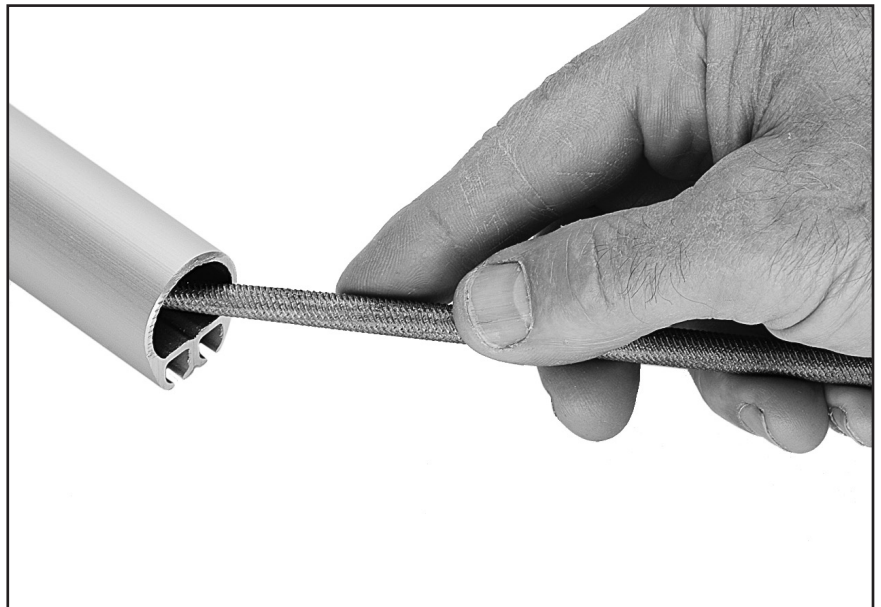

Prepare top foil for drilling.

**Tip: Mark top foil to distinguish from cut-off piece.**

Scribe line on top of foil to mark drill holes. Lay top foil alongside cut-off piece and use a flat metal object (e.g., metal ruler) to scribe top line of foil.

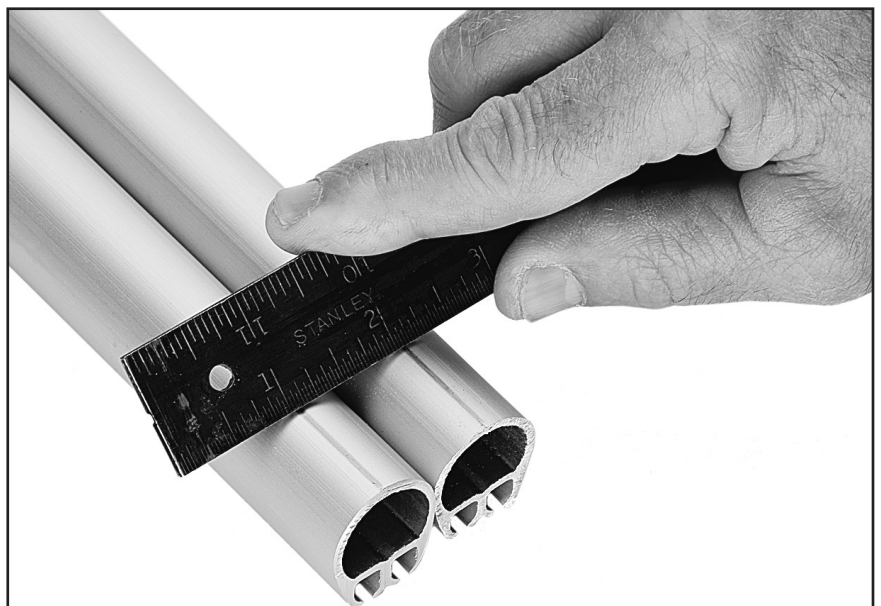

Cut out template at right. Line template up with top of foil and scribed line. Tape in place. Use a center punch to mark holes.

Check center punch marks to confirm they are 3/16" (5 mm) and .8" or 13/16" (20 mm) from top of foil.

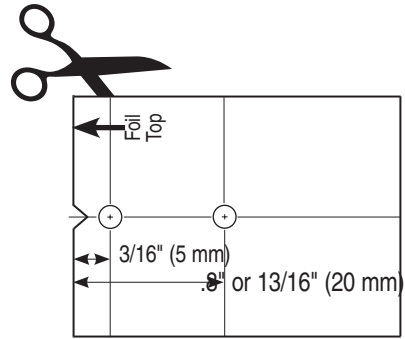

Drill two (2) 1/8" (3.2 mm) holes for trim cap.



Lay top foil in line with others. Slide stay into top foil and down the line of foils or slide each foil up stay.



Install trim cap. Place each side over wire. Assemble halyard deflector if used.

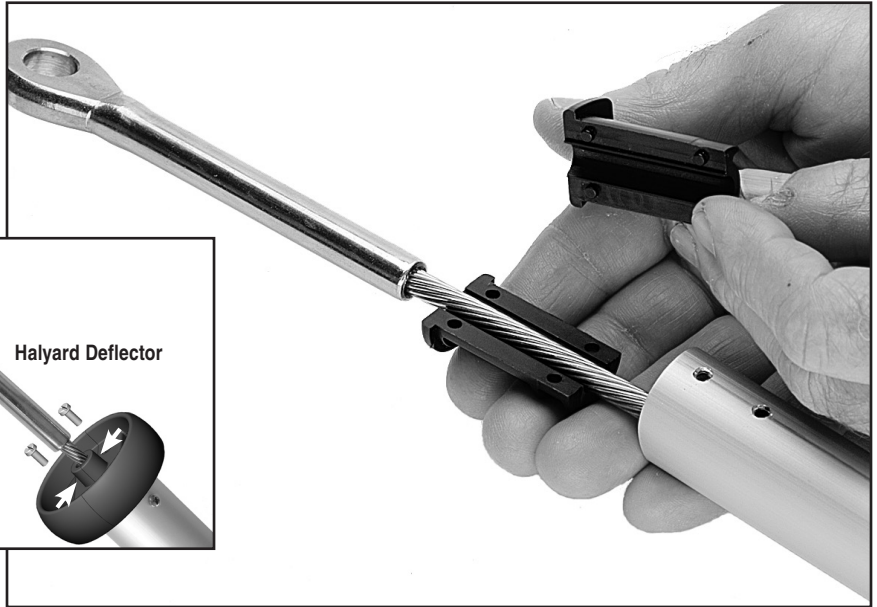
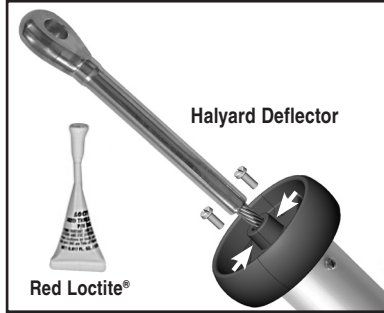

Push trim cap into foil to start then tap in using hammer.  
Install trim cap screws.



Place halves of plastic bushings on stay so hooked part of longer section faces out.  
Tip: With foil screw holes up as shown below, place longer half of isolator with hook on upper half.

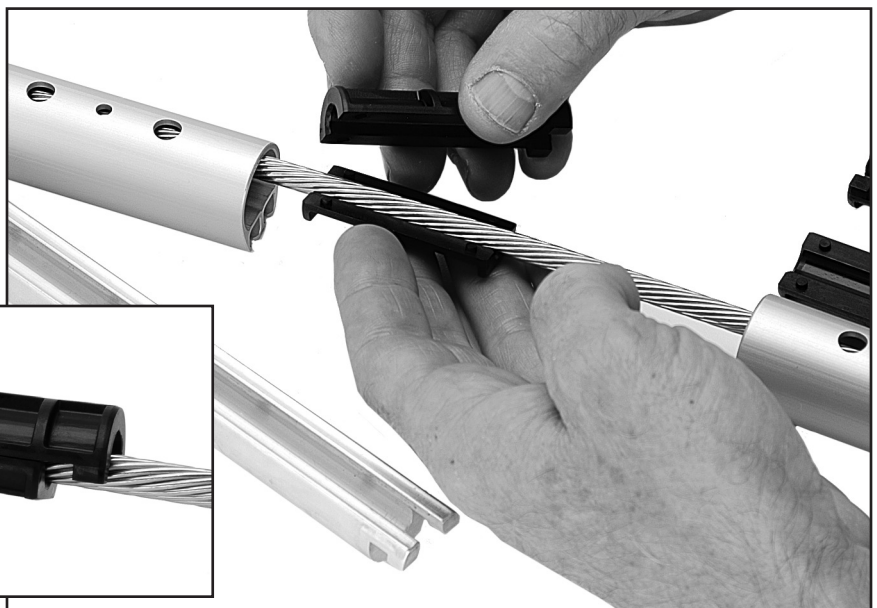

Slip 6.5" (165 mm) connector on wire, mating hook of plastic bushing with connector.



Put a drop of red Loctite® into screw holes.

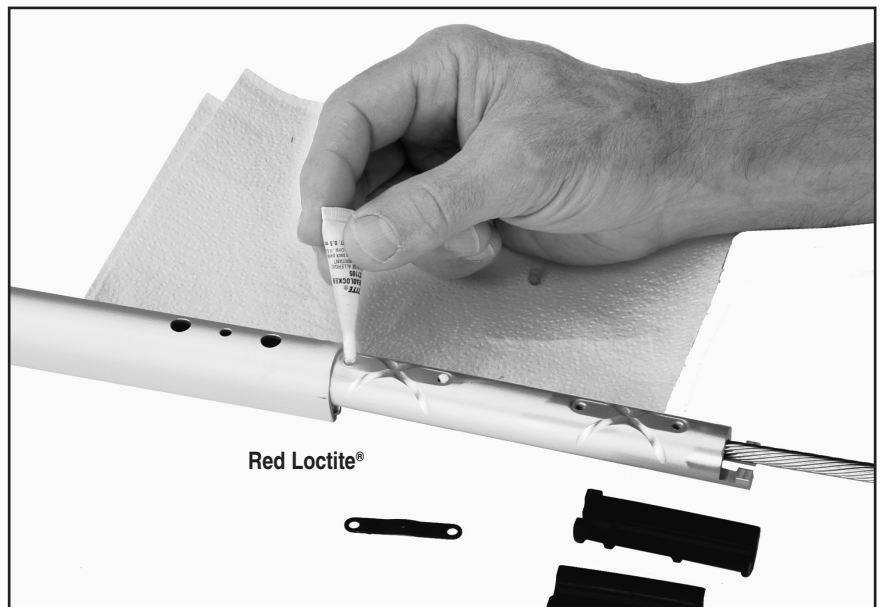

Hold plastic wedge in place with thumb as you insert into foil. Line foil holes with connector screw holes.



**Loading Injector with Adhesive**

**Tip: In cooler weather, keep sealed adhesive in pocket to keep warm.**  
**Use instructions below to fill injector less than half way; you will only use a small amount of adhesive.**  
**Refill if needed but do not keep open sealant for long periods.**  
**Use adhesive within 3 hours.**

Use cap of adhesive to break seal. Remove injector tip cap and plunger. Hold injector at an angle with applicator tip facing down. Squeeze adhesive into tube so lower half of injector is full as shown. Keep tip free of sealant to let air inside.

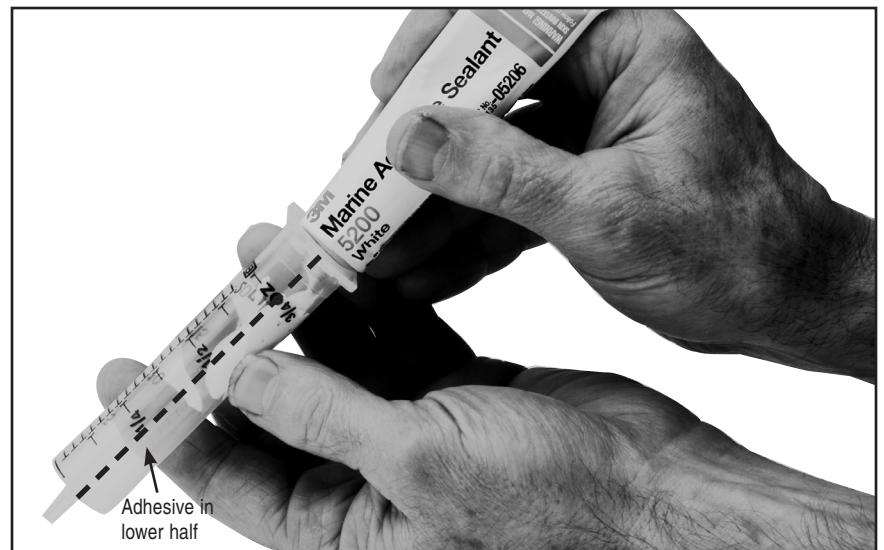

Start plunger into injector and immediately hold upright so plunger is down and applicator tip is up. As sealant runs down towards plunger an air pocket will form near tip. Push plunger to evacuate air. You are now ready to begin injecting adhesive.

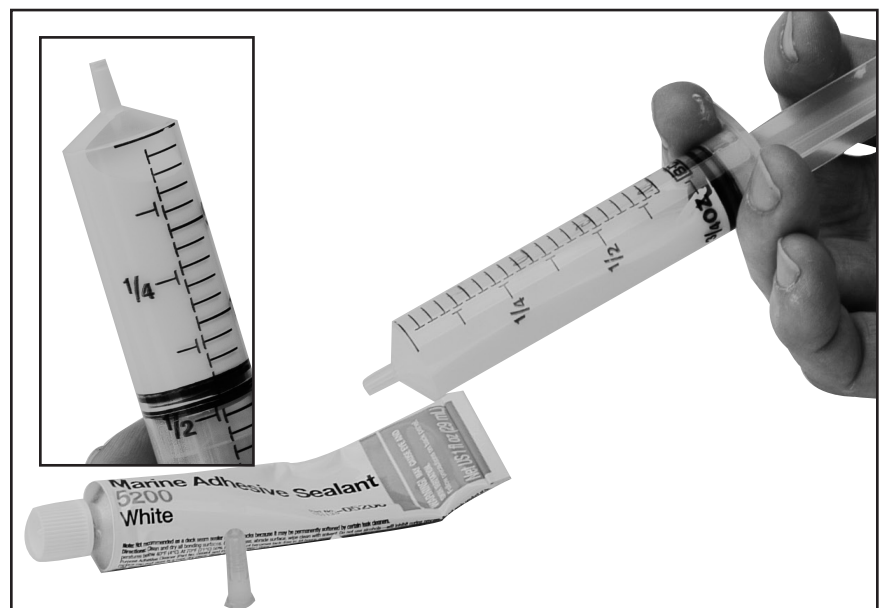

Inject only a small amount. A Unit 0 will only take 1/4 to 1/3 of a graduation mark.

**Tip: When you see a small amount of adhesive enter one of the screw holes, stop—you have applied enough adhesive.**

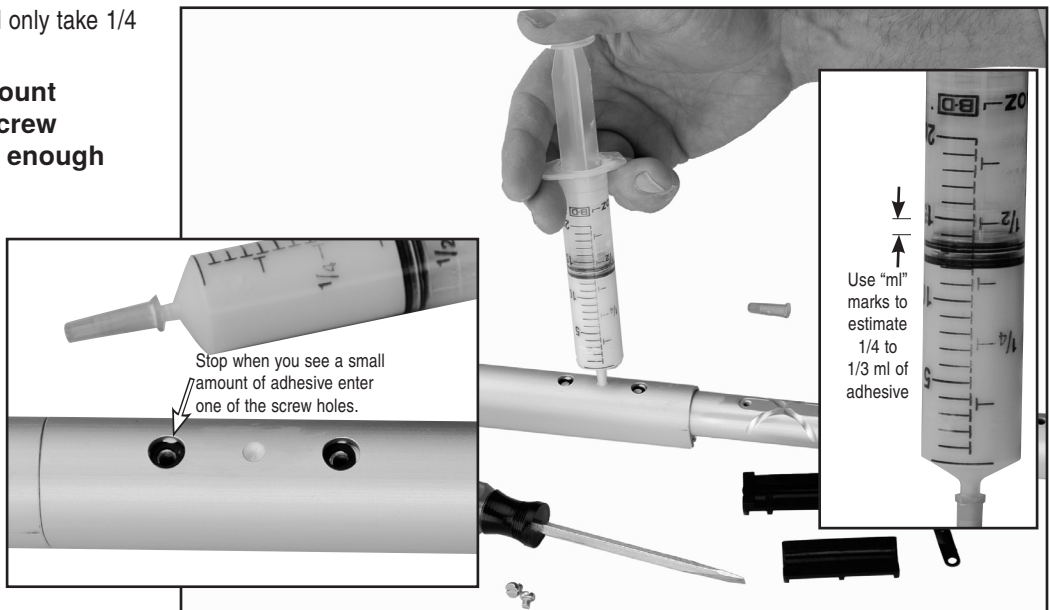

Tighten screws into connector holes. Make sure a drop of red Loctite® entered each screw hole. If not, apply to screw.

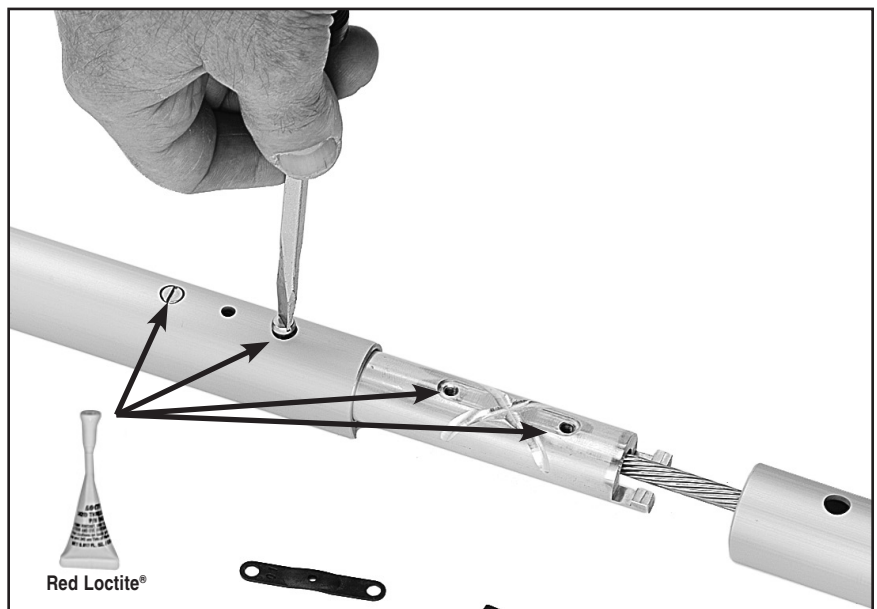

Use bushings, connector, wedge, and red Loctite® in other screw holes and insert into other foil. Then inject 1/4–1/3 ml of adhesive.





Continue installing connectors and wedges.  
Make sure to use red Loctite® in screw holes.

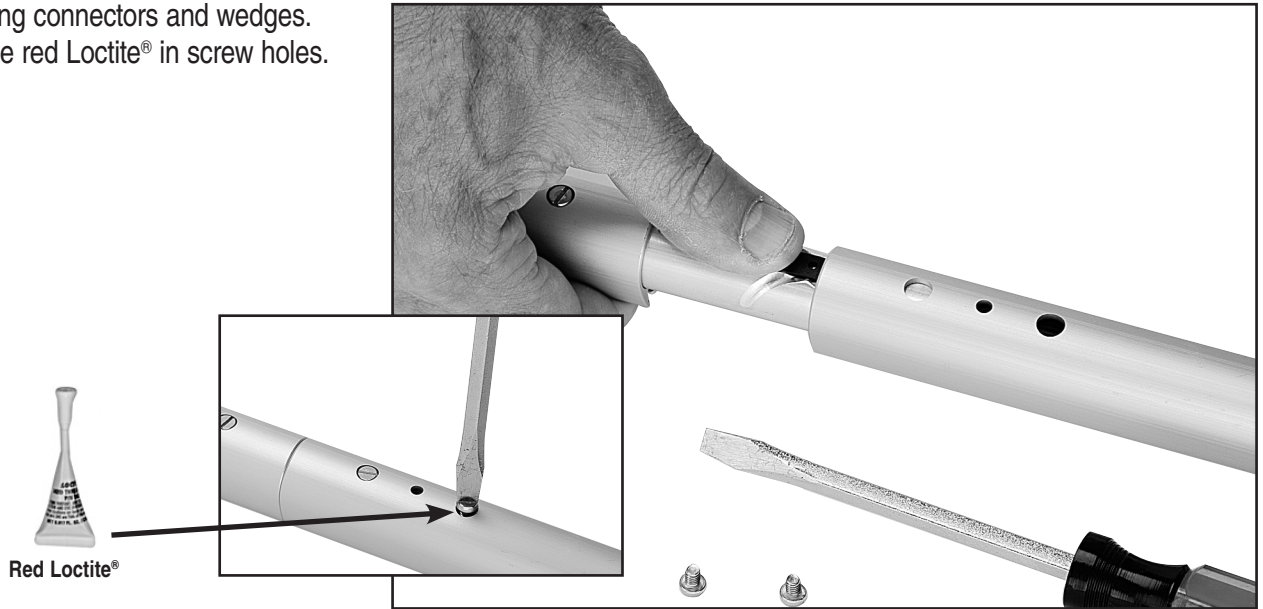

Continue assembly. Use 10" (254 mm)  
bottom connector to assemble bottom foil.

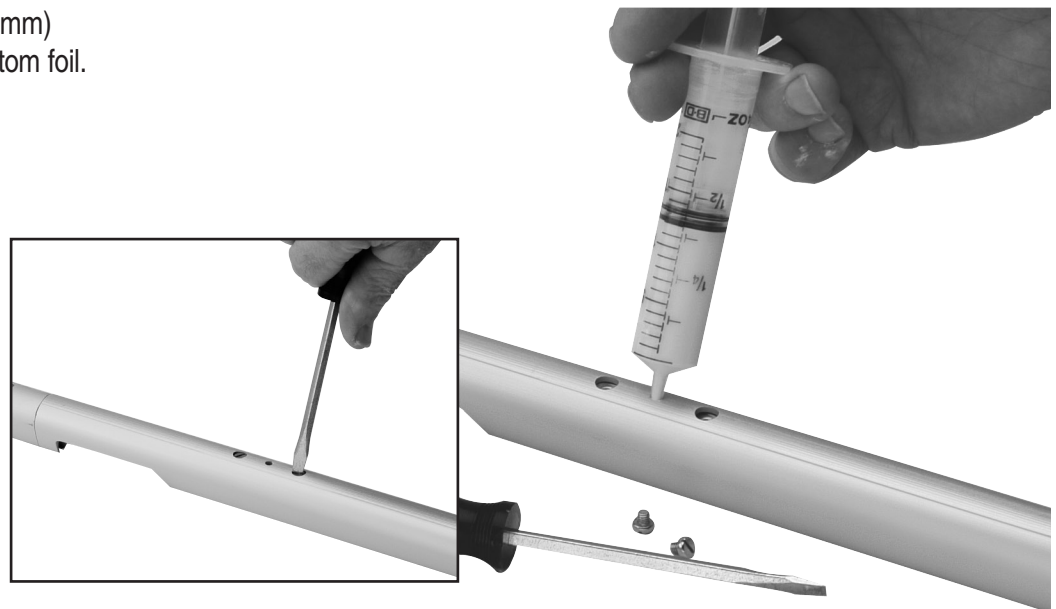

Slide halyard swivel onto foil above feeder window.  
Make sure taller "half" is up as shown.



Loosen foil clamp screws at top of lower unit.



Slide drum assembly onto foils.

**Tip: Face clamp downward so it clears foil notches when installing.**



ROD RIGGING

Apply a few drops of red Loctite® to threads of nosepiece.

Screw main threaded stud portion onto bronze nosepiece until flats align with two cotter pin holes in terminal body.

**Tip: Turn nosepiece completely into threaded stud portion. Flats will be close and may only require a small half turn to align with cotter pin holes.**

Insert two cotter pins and spread. Clean excess Loctite® from terminal body using special care to ensure no red Loctite® is on threaded stud.



Assemble turnbuckle and attach Harken toggle.

**Note:** If using Sta-Lok® or Norseman® stud, you must use a washer above stud as shown below.

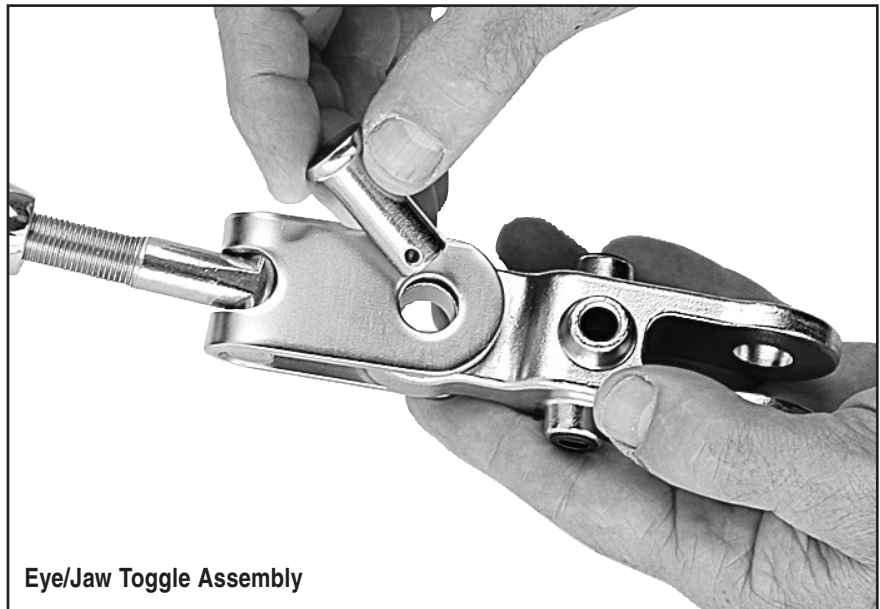
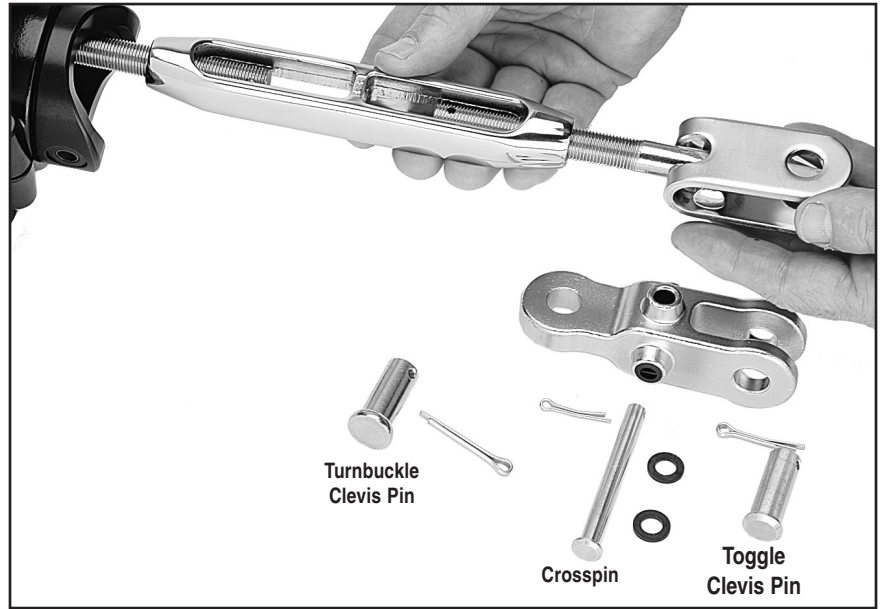
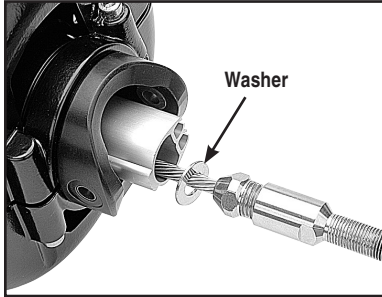

If stay length is set, use side cutters or needle nose pliers to bend cotter pin to secure turnbuckle.



Slide lower unit down over turnbuckle and attach using long crosspin.  
Use plastic bushings provided.

**WARNING!** Crosspin must be at 90 degrees to clevis pin that attaches unit to boat. If pins run same direction toggle will fatigue and could break suddenly.

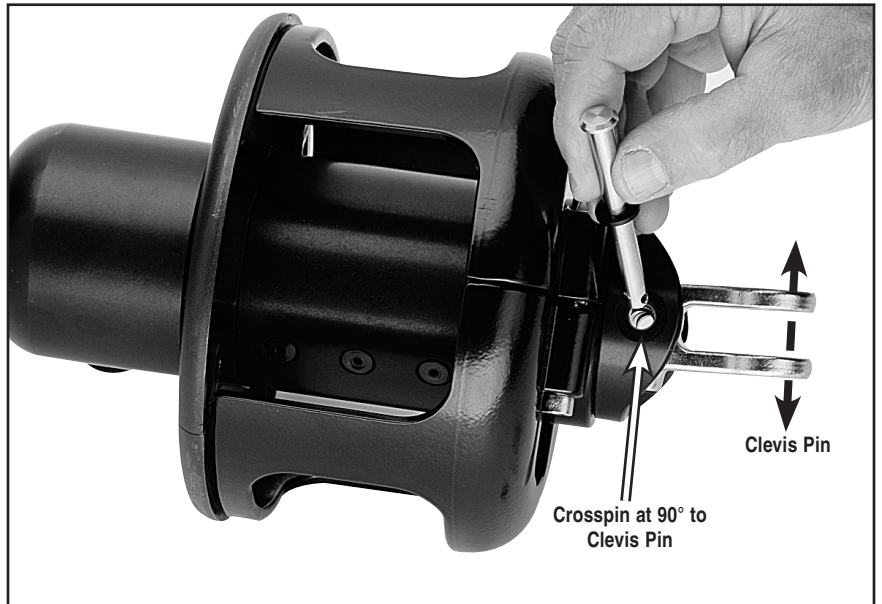

Check foil height at top, set and secure using hex key.  
See tip on next page.



**Tip:** Do not remove foil clamp screws to adjust foil. Loosen screws, hold foils, and bring clamp away from foils. Adjust and reclamp.



Slide halyard swivel above feeder. Place feeder in foil recess. Push screw down so tab catches under foil. Tighten screw.

**Note:** Screw will turn with some difficulty. It is plastic coated to prevent loosening due to vibration.

**IMPORTANT!** When removing screw, loosen no more than one full turn. Slide screw up and remove feeder.



Have extra cotter pins on hand to replace used ones at base of unit and for turnbuckle.

Hold foils and loosen drum assembly screws until you can pull clamp out to lower foils.

Remove crosspin holding drum assembly to turnbuckle.

Raise drum assembly and use halyard to lift and hold it about 5' (1.5 m). Raise foils using second halyard and secure. **Allow room above for turnbuckle take up.**



**CAUTION!** Make sure drum assembly and foils are securely lifted using a halyard before adjusting turnbuckle. Foils can drop suddenly causing injury to hands.

Adjust turnbuckle.

Replace used cotter pins. Lower drum assembly and install clevis pin and new cotter pin.

Lift foils so top is 3/8" (10 mm) below upper terminal.



**WARNING!** Stay must attach to toggle using clevis pin. Do not attach stay to crosspin at drum assembly because crosspin will fatigue and break.

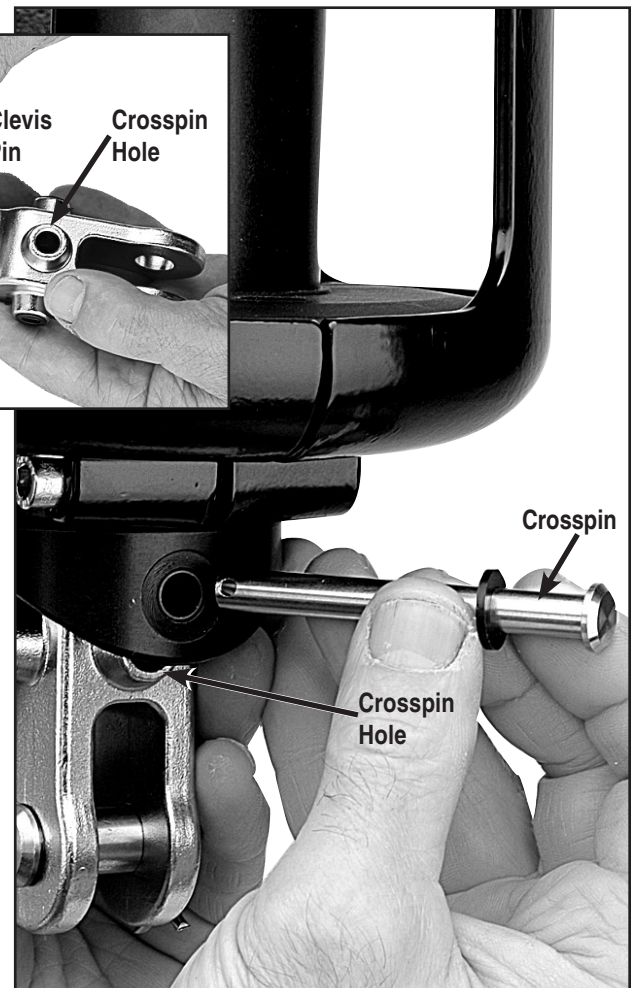
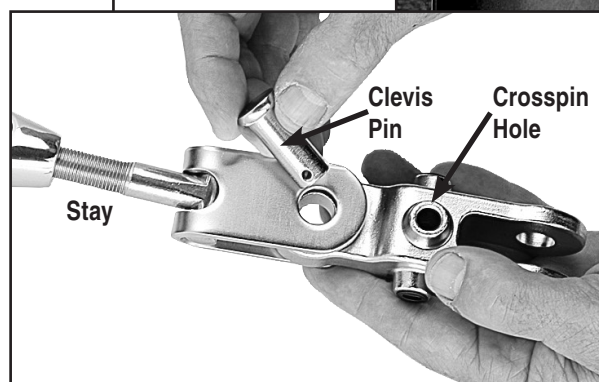
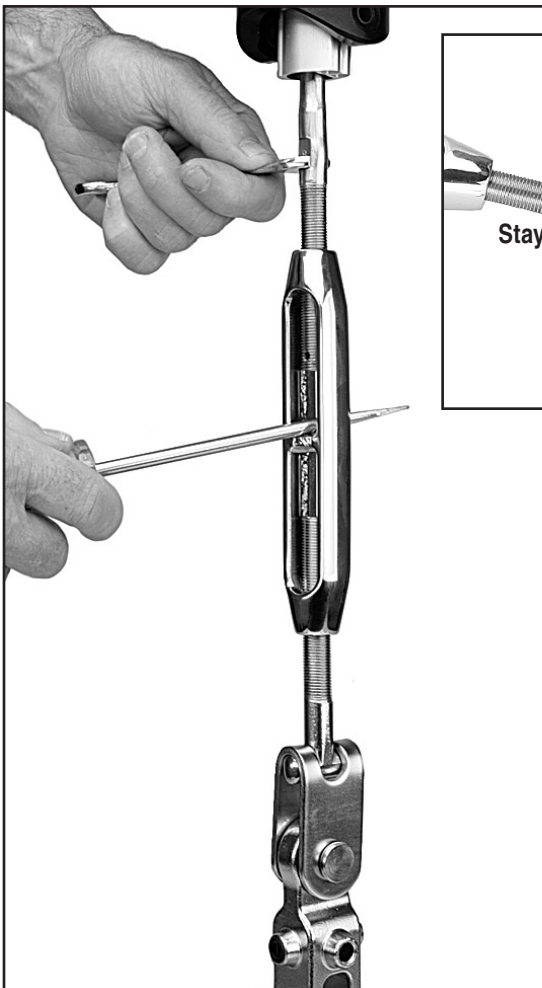

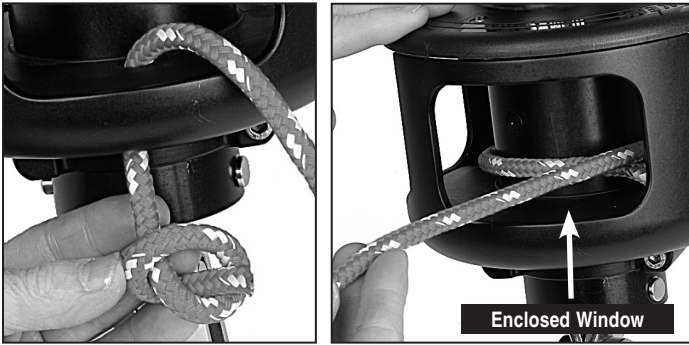

Run line through enclosed window in guard and into hole in bottom plate of spool. Tie a small overhand knot and pull it up under drum assembly.



**WARNING!** Lead line through enclosed window. If line is led through opening between two enclosed windows it can ride above lineguard and jam furler which can cause loss of control of boat.

Note location of sun cover. Charge system by rotating furler to wrap line on drum.

**Tip: Sun cover to starboard—turn clockwise to charge. Sun cover to port—turn counter-clockwise. Tension line while charging.**

**Mount Lead Blocks**

Furling line can be led down either side of boat. If boat is in slip, consider mounting opposite dock.

Remove four screws on stanchion blocks. Clamp blocks to stanchions. See instructions below.

**Tip: Start all four screws before tightening.**

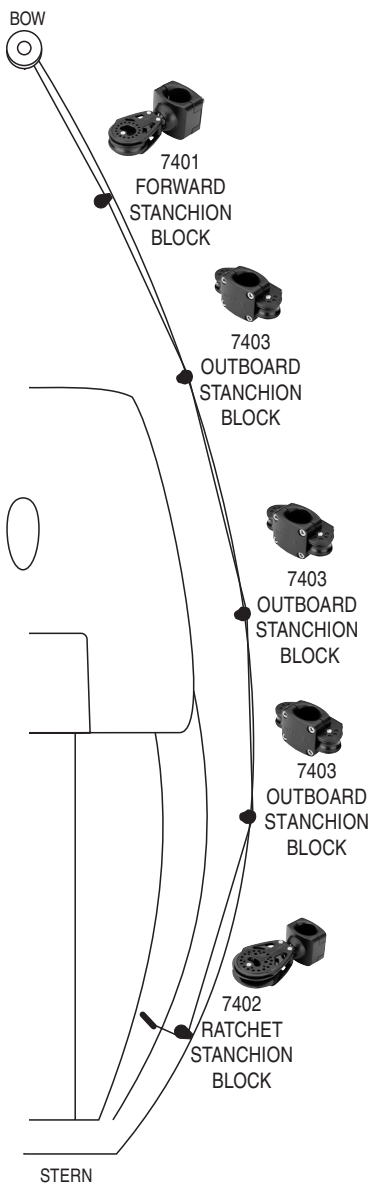

**7401 Forward Stanchion Block**

Position 7401 Forward Stanchion Block so line enters drum at right angles to headstay and centers vertically in opening. Install so line is inside stanchion.

**Tip: Correct block position is critical to even line spooling and ease of furling.**

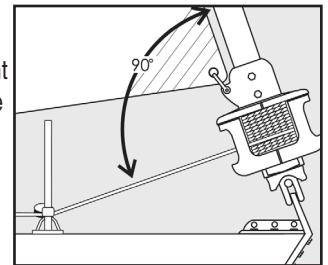

**7403 Outboard Stanchion Blocks**

Install 7403 Outboard Stanchion Blocks so line is outside stanchions.

Number and placement of leads depends on boat length and number/configuration of stanchions.



**7402 Ratchet Stanchion Block**

Mount 7402 Ratchet Stanchion Block as furthest-aft lead to prevent line overrides in drum when unfurling. Position ratchet block so line turns at least 90°.

Install so line is inside stanchion.

**Lead line through block so ratchet makes clicking sound when pulling line to furl sail.**

**Tip: Make sure ratchet sail switch is in "ON" position. If there is no clicking sound, lead line through block in opposite direction.**

Lead line to Furling Line Cleat in cockpit.



**HCP168 Furling Line Cleat**

Install so line is angled as shown. Use #10 (5 mm) fasteners.

**Note:** As furling line lead changes, make sure line doesn't chafe against line guard. Rotate line guard if necessary.

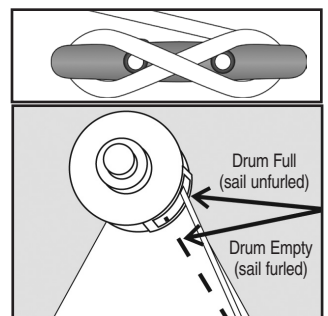



### Halyard Wrap

The most serious problem with furling systems occurs when the jib halyard wraps around the headstay foil. Halyard wraps will keep you from furling or unfurling and may cause serious damage to the unit and the halyard.



**WARNING!** In severe cases, a halyard wrap can cause loss of control of boat and/or headstay can break suddenly. Make sure halyard is clear of top foil before using system.

### If Halyard Wraps

If halyard wraps, do not force unit to turn. Attempt to open sail by carefully furling in and out a little at a time. If sail will unfurl, lower it by releasing jib halyard. Severe halyard wraps can only be cleared by a professional going aloft and freeing halyard.

If sail will not furl or unfurl, try to remove jib sheets and manually wrap sail around headstay.



**WARNING!** Do not go aloft on boat's halyards if there has been a halyard wrap. Do not use boat. Damage to halyard, headstay, stay terminals, or connections as a result of a halyard wrap may cause these parts to break suddenly causing mast to fall down while person is aloft. Sailing or motoring with boat after a wrap can result in the headstay breaking and mast falling down. Before using boat, have a professional rigger inspect and replace parts as necessary using following methods.

A professional rigger must carefully inspect the masthead area using a secure hoisting method. Inform rigger that there has been a halyard wrap so they can avoid an accident by relying on standing rigging or halyards. Inspection must be done while rigger is suspended from a separate crane or mast must be lowered to perform inspection. Some professionals may rig a new line through internal masthead sheaves to serve as a temporary headstay to hold mast in place. Wire, rod rigging, terminals, toggles, clevis pins, or cotter pins must be inspected and replaced if they show any signs of damage.

### Prevent Halyard Wrap

To prevent wraps, the halyard must exert a slight pull to the rear. This allows the foils to turn while halyard remains stationary.



**WARNING!** Sail must be fitted to foil length before using to prevent halyard wraps and possible headstay loss.

1. Halyard swivel should be within top 4–6" (100–152 mm) of foil unless a halyard restrainer is used.
2. Halyard must pull slightly to rear (8–10°).
3. Halyard must be snug, but not too tight.

**Tip:** Test furler at dock, but if water is smooth an incorrect lead angle may not be apparent. Halyard wraps usually occur in wave action when lead angle is not correct. The 8–10° angle shown at right is critical.

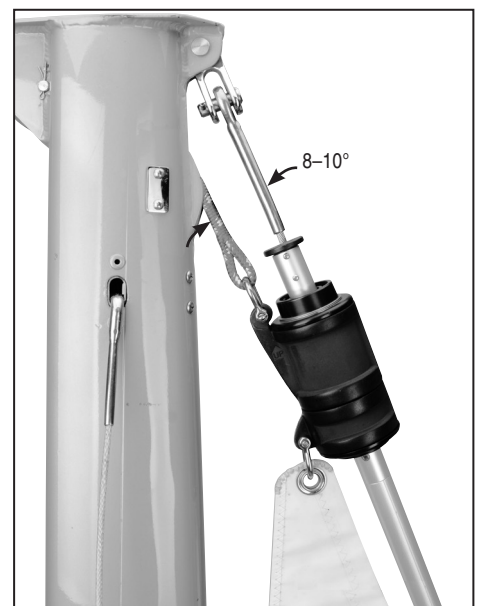

**Pendants**

If the your sail luff is not long enough to position halyard swivel high enough to create an 8–10° angle as shown, you must add a pendant. Pendants should be made of plastic-coated wire and be permanently attached so sail height will be correct. Adjustable-length pendants are not acceptable, as they might not be adjusted correctly during a sail change.

1. Raise sail, but do not attach tack shackle.
2. Position halyard swivel correctly near top of headstay.
3. Secure halyard.
4. Tie a piece of rope to sail tack.
5. Lead line through tack shackle on furling drum.
6. Tension sail.
7. Measure distance from tack shackle to sail tack and permanently attach pendant of this length to head of sail.
8. Repeat procedure for every jib in your sail inventory.

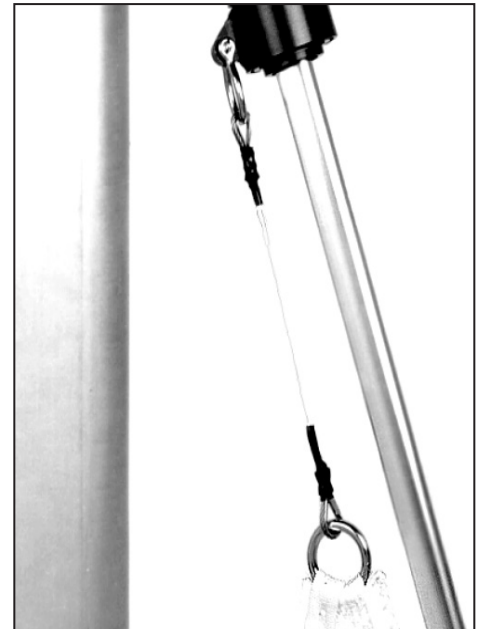

**Halyard Deflector / Halyard Restrainer**

To prevent wraps, jib halyard must pull slightly to rear. On most boats, halyard lead angle is acceptable if halyard swivel is raised to top of foil.

On some boats halyard sheaves are located too close to headstay and a halyard deflector or halyard restrainer must be used.

Halyard restrainers should be used only when required by masthead geometry. Restrainers tend to limit sail luff length and may cause problems if not installed properly.

If your boat needs a halyard deflector, use part number 7301 or halyard restrainer, use Harken Part No. 945.

Restrainer should be mounted as high as possible on face of mast. Position restrainer so that foils will not hit it when under load.

The restrainer should deflect halyard as little as possible or you may experience difficulty in tensioning sail luff, friction when furling, and possible damage to foils. To decrease deflection angles, shorten sail luff.

**Tip: Boats used in charter service should have a halyard restrainer, regardless of masthead geometry.**



Halyard Deflector

**Halyard Tension**

The jib halyard should be firm, but not too tight.

**Tip: The luff foil system supports sail along its length so halyard tension is used only to shape sails, not to support them. Use enough halyard tension to remove some wrinkles along luff of sail. Do not tension halyard enough to cause vertical wrinkles in luff of sail. Tension to adjust position of draft in sail to suit sailing conditions. Halyard should be firm but not tight. If in doubt, release halyard tension. To protect sail, ease halyard when boat is not in use.**



Halyard Restrainer

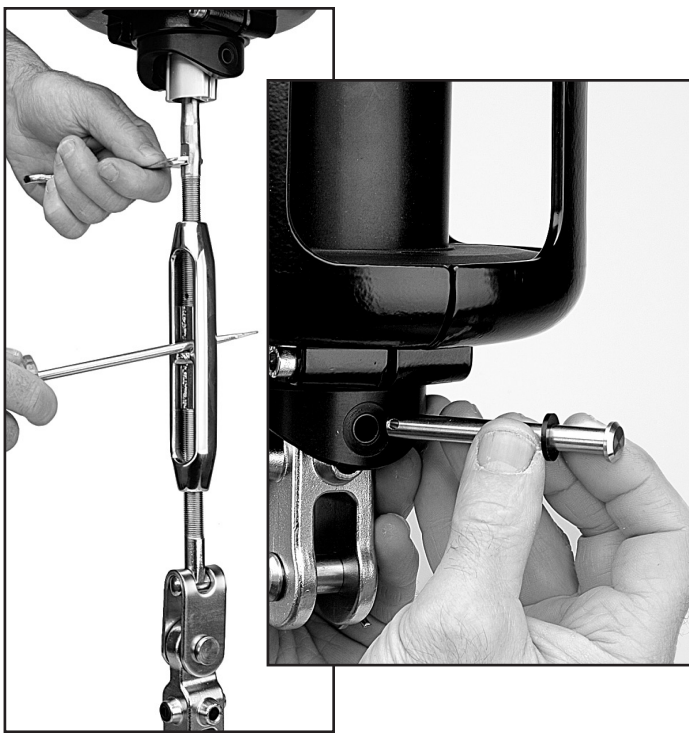
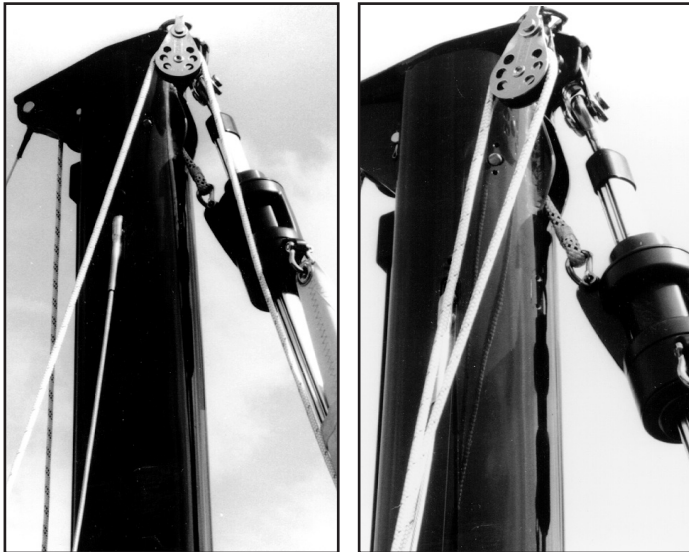

### Backstay Adjuster

Backstay adjusters allow headstay tension to be varied to change sail shape to match conditions. They permit a very tight headstay to be eased when boat is not in use. For best performance, consider adding a backstay adjuster; either a block and tackle, a mechanical adjuster like those offered by Harken, or a hydraulic adjuster.

Remember to keep headstay tight for best performance when furling or reefing.

If your boat is fitted with an adjuster be sure that it is tensioned **before** the halyard is tensioned. If not, backstay adjuster may increase halyard tension and could damage the sail or furling system.

Racing boats often slack the headstay completely when sailing downwind. Check to be sure that foil does not jam against upper headstay terminal when backstay is released. To prevent this, it may be necessary to shorten foil slightly.

### Spinnaker Halyards

Spinnaker halyards occasionally cause problems with furling.



**WARNING!** In severe cases, spinnaker halyards can jam furler causing loss of control of boat. Make sure halyards are clear of top of foils and halyard swivel.

On many boats it will not be possible to attach spinnaker halyard to bow pulpit or it may be "sucked" into jib when furling.

On some boats the spinnaker halyard lays across headstay and will catch on halyard swivel, foils or jib halyard. To prevent problems it may be necessary to install a masthead bail to move spinnaker halyard block forward and to one side.

Boats with external halyards may find it necessary to flip both ends of spinnaker halyard behind spreaders to prevent fouling with furling system.

### Headstay Tension

A furling system will work best if headstay is tight.

A loose headstay is difficult to rotate and can cause unusual wear on foil joints.

To adjust headstay tension, remove sail and furling line from unit and follow instructions on page 23.

**Tip: Before adjusting headstay tension, slack mainsheet and vang.**





### Raise Sails

1. Install prefeeder by securely tying end of line to a deck fitting or to toggle below furler so it is 2' (610 mm) below feeder.
2. Shackle tack of sail to drum. Install shackle so screw pin head is on same side as sun cover.
3. Secure genoa sheets to clew of sail.
4. Attach genoa halyard to halyard swivel.
5. Pass luff tape through prefeeder and feeder into foil groove.
6. Attach head of sail or pendant at head of sail to halyard swivel.
7. Hoist sail.

**Tip: New sails are often stiff and may hang up on prefeeder during raising. Do not force sail when it hangs up—lower and remove twist. Sails "break in" with use and will become easier to raise.**

### Storm Sails

Most people will use one multi-purpose genoa for all their sailing, but it is not good seamanship to go offshore without storm sails.

Heavy-air working jibs and storm sails may be used with your unit. These sails need to have luff tape added to allow them to be raised in headstay foils.

These sails will generally require pendants to ensure that halyard swivel is properly positioned at top of headstay. See page 26.

Remember that heavy-air working jibs and storm jibs may be reefed and furled like any other sail.

### Furl and Reef

To furl or reef, ease the jib sheets and pull furling line.

In very light air, it may be necessary to place some tension on jib sheet to insure a tight furl.

In a breeze, you must **completely** luff sail by **totally** slacking jib sheets before furling.

The furling line should pull readily. The amount of force required is related to amount of wind, but Unit should never require use of a winch to furl. If the sail will not furl, or if furling requires a great deal of effort, there is a problem with system. Consult the Troubleshooting Guide on Page 32. Do not use a winch to force a system to turn. If you are certain that the system is operating properly, you may use a winch to make furling easier.



**Reef**

A sail may be partially furled before you resume sailing. This is known as reefing.

Many sailors find it helpful to place marks on foot of sail so that they can reef to a variety of predetermined jib sizes. This allows marks to be placed on jib lead tracks or toe rail so that lead block position can be changed to correspond to reefed jib.

Sails are generally reefed to balance boat and to reduce heeling moment. Sails may also be reefed to improve visibility or to slow boat while sailing in congested areas or entering or leaving harbors.



**Secure Sail**

When furling the sail completely, make sure sheets and furling line are secured. Check amount of line on the spool compared to the furled sail before using the system.

A furled sail must have:

- a. Two to three wraps of jib sheet wrapped around sail.
- b. Two wraps minimum of line wound on spool.
- c. Furling line securely cleated.
- d. Jib sheets securely wrapped on winch and held in self-tailing jaws.

Furl at dock with tension on sheets to duplicate furling in high wind.

Remember sails furled in light wind and left loosely secured can be a problem if wind increases.

**IMPORTANT! Remove sail from furler if extreme winds are predicted, especially if boat is left unattended.**

**IMPORTANT! Check all points above—a, b, c, and d—when leaving boat to avoid damage to furler or boat.**

A loosely rolled sail can catch wind in a storm. Sheets or furling lines can loosen as winds increase and allow furler to unroll. If no wraps of line are on spool, the line deadend can break the drum when the boat motors through waves.

Be sure mooring lines are not placed across furling line where they may cause chafe.



**If you want to:**

<b>Add more wraps of jibsheet on furled sail.</b>	Untie jib sheets and keep sail completely rolled. Secure with sail tie.	Turn spool to unroll a couple of wraps of line.	Retie sheets.
<b>Add more wraps of line on spool.</b>		Turn spool to add a couple of wraps of line.	

Race conversion allows use of both grooves for sail changes and tacking genoas on deck for use of maximum luff length genoas.

### Halyard Swivel Below Feeder

Use halyard to lift halyard swivel up, away from feeder. Loosen screw **one revolution only**. Slide screw up and hold. Remove feeder carefully—bottom end first. **Don't lose the feeder overboard!** Lower swivel onto torque tube. Replace feeder.

### Remove Feeder



Loosen screw one revolution only.

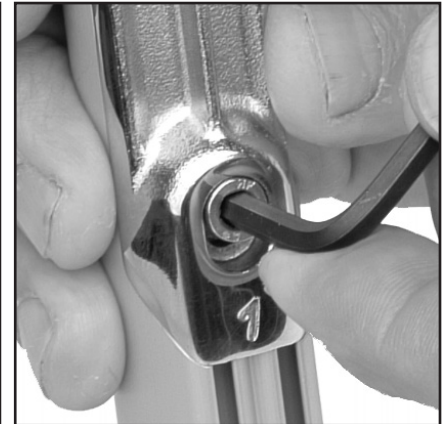

Slide screw up and hold.



Carefully remove feeder—bottom end first. Don't drop the feeder overboard!

### Halyard Swivel Off Furler

Serious racers may want to remove the halyard swivel.

**Note:** It is not possible to remove halyard swivel on a unit with a Norseman/Sta-Lok or rod adapter stud unless you disassemble terminal stud. Make sure you use a new Norseman/Sta-Lok wedge to reassemble Norseman/Sta-Lok fitting.

- 1) Remove drum assembly.
- 2) Rig a secure, temporary headstay.
- 3) Loosen backstay, mainsheet, and vang so that headstay goes slack.
- 4) Remove clevis pin holding furling unit to chainplate.
- 5) See adjusting turnbuckle on Page 23. Remove turnbuckle body and lower unit and slide off halyard swivel.
- 6) Reattach headstay to boat.

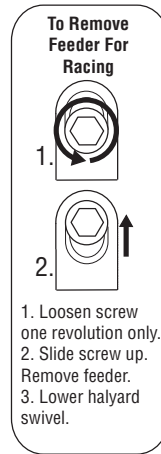

### Removing Drum

- 1) Remove sail and unwind the line from drum. Line can remain attached to drum.
- 2) Use 5 mm hex key provided to remove 2 screws on bottom of guard assembly and remove two halves. Be careful—screws are not captive.
- 3) Use a 2.5 mm hex key to loosen four screws in plastic cover and flange.





### Clean and Lubricate

Keep unit clean. When you wash boat, flush unit with soap and fresh water. Occasionally lower sail and flush halyard swivel with soap and fresh water.

At least twice a year unit should be cleaned more thoroughly by removing line (first note direction of spool) and flushing bearings with soap and fresh water.

Foils may be cleaned by washing with soap and water. A scrap of luff tape may be run up foil to scrub inside grooves. If lubrication is required, spray a thin coat of McLube® SailKote on sail luff tapes away from boat deck.



**WARNING!** Do not spray sail or foil on boat. McLube® will cause slippery decks which may result in loss of footing, falling overboard.



**WARNING!** Periodically inspect items listed below and any others as necessary. Failure to inspect can cause an accident.

### Inspect

Inspect unit for signs of chafe, wear, or damage.

Inspect clevis and cotter pins below and inside drum assembly for signs of loosening. Check headstay tension for signs of loosening.

Inspect swage fitting and lower toggle for signs of stress corrosion.

Inspect Norseman or Sta-Lok terminal or rod terminal for signs of loosening.

Inspect all screws on unit to be sure they have not loosened.

Inspect foil to make sure that it has not dropped into drum assembly.

Periodically inspect wire for signs of wear or unraveling.

### Replace Line

Use Harken HFG594 furling line or source a good-quality, double-braid polyester line with good wear characteristics. Use 9/32" (7 mm) line with break strength exceeding 2500 lbs (1130 kg). Smaller boats or smaller sails may allow 5/16" (8 mm) line. If a larger-diameter line is desired, consult with a rigger about using tapered line with a high strength core and cover removed in forward part of line.

### Storage – Mast Down

In areas where it freezes, do not store system where water can accumulate in foils. When water freezes it will rupture aluminum. Store foils under cover, with grooves facing down or on an angle so water will run out.

### Storage/Transporting

Do not store or transport system with drum assembly extending beyond mast. Remove masthead clevis pin and shift furler up so drum assembly can be strapped securely to mast. Some people remove drum assembly and halyard swivel for storage and transport.

### After Storage or Transport

After storing or transporting unit, clean thoroughly including ball bearings. See instructions above.

### Loosen Foil Clamp Before Slacking Backstay

In order to prevent foils from locking against upper stay terminal when backstay is released, loosen foil clamp screws and lower foil before loosening backstay.



## Troubleshoot

Problem	Probable Cause	Solution
Sail will not furl or is difficult to furl.	Jib halyard is wrapping around headstay because angle between mast and halyard is too shallow	See installation instructions regarding optimal halyard angle. It may be necessary to mount a halyard restrainer on front of your mast to hold halyard to rear.
	Jib halyard is wrapping around the headstay because halyard swivel is too low.	See installation instructions regarding optimal halyard swivel height. A wire pendant may be needed at head of sail to raise halyard swivel to proper height.
	Jib halyard is too tight.	Ease jib halyard.
	Foils riding on turnbuckle.	Raise foils. See adjusting turnbuckle on page 23.
	Foils too high, binding on swage eye.	Lower foils until clear. See adjusting turnbuckle on page 23.
	Spare halyard is wrapping in sail as it furls.	Secure spare halyards away from furling headstay by flipping them behind spreaders
	Salt or dirt in bearings.	Flush bearings frequently with fresh water and a detergent solution.
	Furling line tangled in drum.	Overrides are best prevented by using a 7402 ratchet block as the last furling line lead to maintain proper drag on line while unfurling.
	Stop knot catching.	Make sure knot is a single overhand and is pushed up inside drum.
	Sail full of wind.	Luff completely before furling or reefing.
	Sail flogging too much.	Release a short length of sheet, pull some furling line and repeat.
	Jib sheets are not free.	Free jib sheets.
	Foil out of drum assembly.	Reinstall foil in drum assembly and tighten clamp screws.
	No wraps of furling line on drum.	Remove sheets. Rotate stay wrapping as much furling line on drum as possible.
	Lineguard assembly has slipped down.	Tighten line guard assembly screws securely.
	Line through 7402 ratchet backwards.	Rerun line.
Halyard swivel installed upside down.	Remount swivel correctly.	
Sail will not unfurl or will not unfurl completely.	Jib halyard is wrapping around headstay because angle between mast and halyard is too shallow.	See installation instructions regarding optimal halyard angle. It may be necessary to mount a halyard restrainer on front of your mast to hold halyard to rear.
	Jib halyard is wrapping around the headstay because the halyard swivel is too low.	See installation instructions regarding optimal halyard angle.
	Foils riding on turnbuckle.	Raise foils. See adjusting turnbuckle on page 23.
	Foils too high, binding on swage eye.	Lower foils. See adjusting turnbuckle on page 23.
	Jib halyard is too tight.	Ease jib halyard.
	Spare halyard is wrapping in sail as it furls.	Secure spare halyards away from furling headstay by flipping them behind spreaders
	Salt or dirt in bearings.	Flush bearings frequently with fresh water and a detergent solution.
	Furling line is not free.	Free furling line.
Sail will not furl completely.	Insufficient furling line on drum.	Remove sheets. Rotate stay, wrapping as much furling line on drum as possible.
	Too much line on drum.	Adjust amount of line on drum or change position of forward lead block to allow line to roll evenly on drum.
	Spare halyard catching in sail as it furls.	Move halyards away from furling headsail as above.
Headstay rotates in jerks or elliptically.	Insufficient tension on headstay.	Tighten headstay and/or backstay to eliminate sag in headstay.
Sail does not stay furled.	Sail not furled tightly on stay.	Maintain drag on sheets while furling.
	Furling line not secure.	Secure furling line.
Sail will not go up.	Luff tape will not go into groove.	Check luff tape for fraying. Check luff tape size.
	Sail catching at prefeeder.	Flake sail more loosely on deck.
	Dirt in groove.	Clean groove.
Sail will not raise completely or luff will not tension.	Halyard swivel is hitting end stop.	Luff of sail is too long and must be recut.
	Angle between halyard and mast is too sharp and halyard is pulling too much to the rear.	Halyard must be routed from a point higher on mast. This may require that any halyard turning blocks aloft be replaced or sail shortened.
Sail will not come down.	Halyard is wrapping on headstay.	Angle between headstay and halyard is too shallow and must be optimized per installation instructions.
	Halyard swivel off foil.	Sail luff too long or foil is too short or low and must be lengthened or raised.
Ultraviolet cover rolls up inside of sail.	Furling line is wrapped on drum in wrong direction.	Remove sheets. Pull line to remove all furling line from drum. Turn stay to rewind line on drum in opposite direction. Line guard and cowling alignment may need to be adjusted.
Line jams between guard and plastic spool plate.	Line is not led through windows.	Pull line through enclosed window.

Warranty — Online at [www.harken.com/manuals](http://www.harken.com/manuals) or call, write, email or fax Harken, Inc., Pewaukee, WI USA



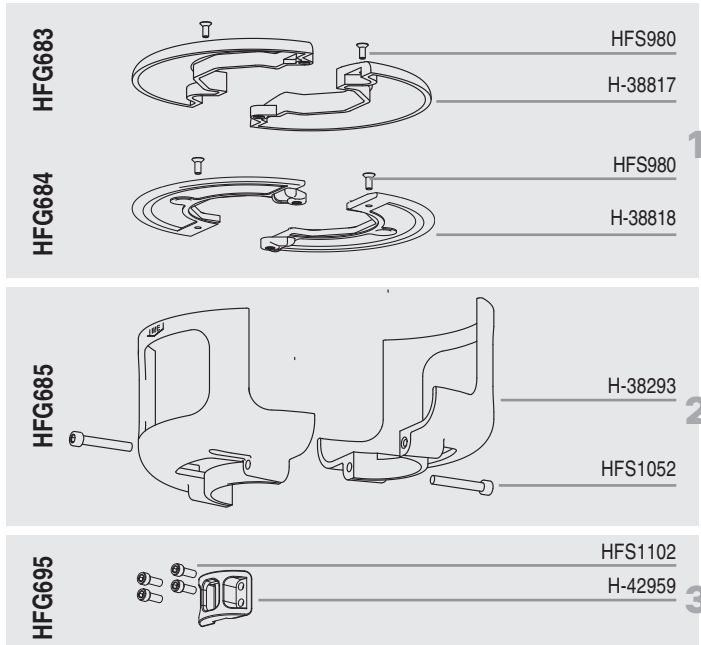

	Description	Order	Part No.
<b>1</b>	<b>Top Cover Assembly w/Screws</b>	<b>1</b>	<b>HFG683</b>
	Top Cover	2	H-38817
	Top Cover Screw	2	HFS980
	<b>Bottom Flange Assembly w/Screws</b>	<b>1</b>	<b>HFG684</b>
	Flange	2	H-38818
	Bottom Flange Screw	2	HFS980
<b>2</b>	<b>Guard Assembly</b>	<b>1</b>	<b>HFG685</b>
	Guard Set	2	H-38293
	Guard Screw	2	HFS1052
<b>3</b>	<b>Clamp with Screws</b>	<b>1</b>	<b>HFG695</b>
	Clamp	1	H-42959
	Clamp Screw	4	HFS1102
	<b>4</b>	<b>Hub Assembly</b>	<b>1</b>
	Ball Plugs	5	H-36865
	Torlon® Ball Bearing	26	MP-126
	Delrin® Ball Bearing	104	MP-122
	Igus® Crosspin Bushing	2	HCP1744

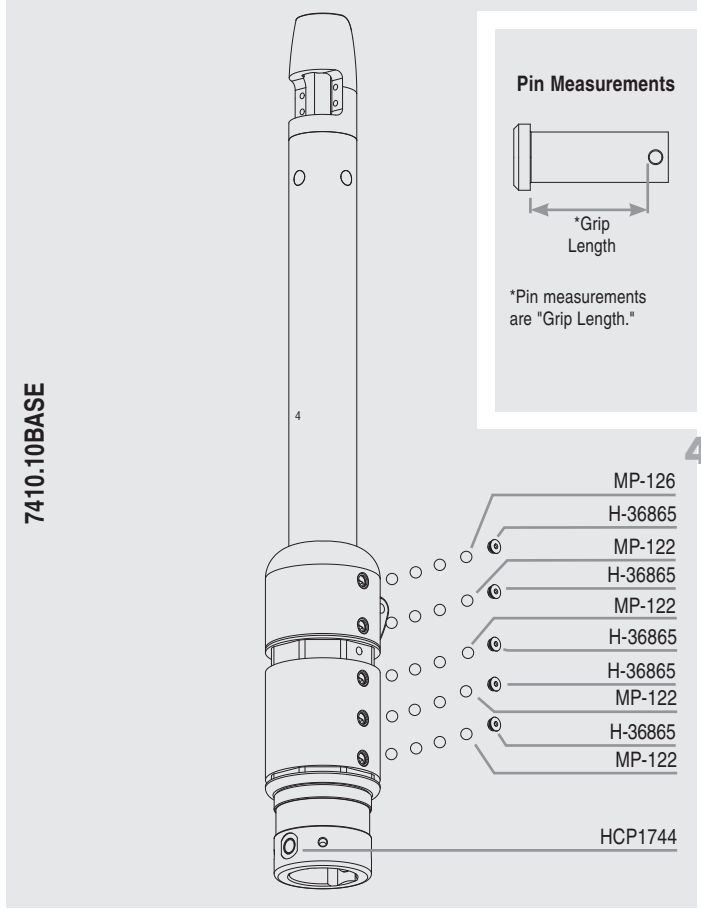

No.	Description	Order	Part No.
<b>5</b>	<b>Eye/Jaw Toggle Reversible 5/16" (7.9 mm) Pin</b>	<b>1</b>	<b>7410.20 5/16</b>
	1 Toggle	1	H-63528
	2 Crosspin (1/4" x 21/8")	1	H-42401
	3 Nylon Washer	2	HFS1108
	4 Cross Hole Plug	2	H-42050
	5 Clevis Pin (5/16" x 13/16")	1	SP-039
	6 Cotter Pin (3/32" x 3/4")	2	HFS181
	<b>Eye/Jaw Toggle Reversible 3/8" (9.5 mm) Pin</b>	<b>1</b>	<b>7410.20 3/8</b>
	1 Toggle	1	H-37687C
	2 Crosspin (1/4" x 21/8")	1	H-42401
	3 Nylon Washer	2	HFS1108
	4 Cross Hole Plug	2	H-42050
	5 Clevis Pin (3/8" x 7/8")	1	H-42400
	6 Cotter Pin (3/32" x 3/4")	2	HFS181
	<b>Eye/Jaw Toggle Reversible 7/16" (11.1 mm) Pin</b>	<b>1</b>	<b>7410.20 7/16</b>
	1 Toggle	1	H-37688C
	2 Crosspin (1/4" x 21/8")	1	H-42401
	3 Nylon Washer	2	HFS1108
	4 Cross Hole Plug	2	H-42050
	5 Clevis Pin (7/16" x 1")	1	H-42399
	6 Cotter Pin (3/32" x 3/4")	2	HFS181

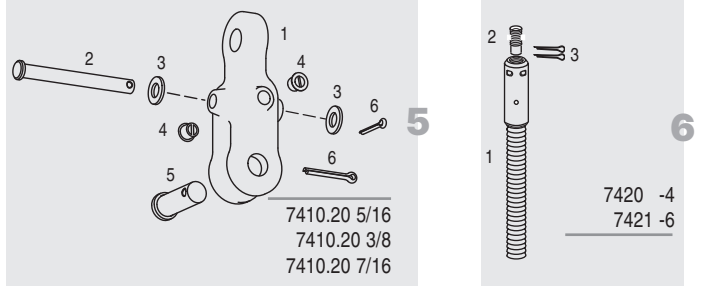

No.	Description	Order	Part No.
<b>6</b>	<b>Rod Adapter Stud (-4) w/Nosepiece</b>	<b>1</b>	<b>7420 -4</b>
	1 Stud (Main Body)	1	H-41707
	2 Nosepiece	1	H-41708
	3 Cotter Pin (3/32" x 3/4")	2	HFS181
	<b>Rod Adapter Stud (-6) w/Nosepiece</b>	<b>1</b>	<b>7421 -6</b>
	1 Stud (Main Body)	1	H-41705
	2 Nosepiece	1	H-41706
	3 Cotter Pin (3/32" x 3/4")	2	HFS181

Torlon is a registered trademark of Solvay Advanced Polymers L.L.C.  
 Delrin is a registered trademark of E. I. du Pont de Nemours and Company or its affiliates.  
 Igus is a registered trademark of Igus GmbH and/or Igus, Inc.

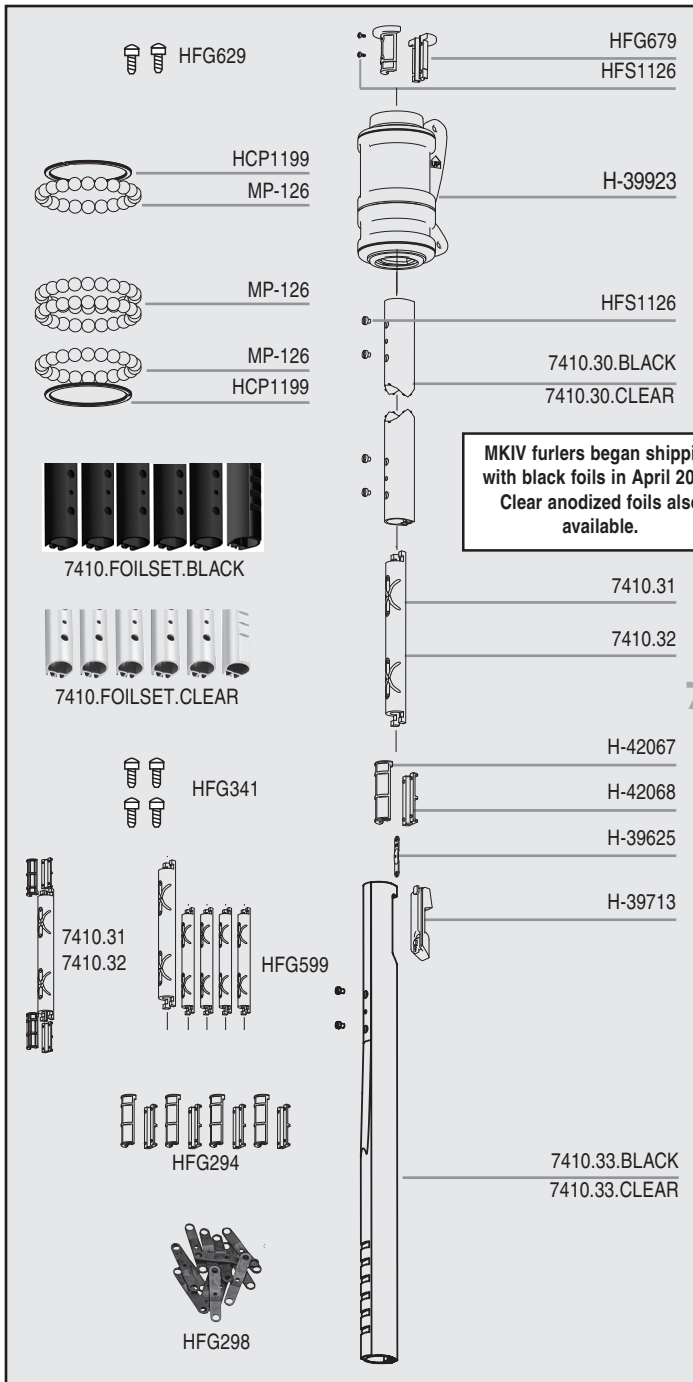

MKIV furlers began shipping with black foils in April 2021. Clear anodized foils also available.

Description	Order	Part No.
<b>7 Trim Cap Set w/o Screws</b>	1	<b>HFG679</b>
<b>Trim Cap Screw Set</b>	1	<b>HFG629</b>
Trim Cap Screw	2	HFS1126
<b>Halyard Swivel w/o Shackles</b>	1	<b>H-39923</b>
Torlon® Ball Bearings	96	HSB17
Clip/Smalley Ring	2	HCP1199
<b>7410.10.FOILSET. BLACK</b>		
<b>Foil Set, Black</b>		
Foil (7' / 2.13 m) Luff, <b>Black Anodized</b>	5	7410.30.BLACK
Foil (2' / 610 mm) Bottom, <b>Black Anodized</b>	1	7410.33.BLACK
<b>7410.10.FOILSET. CLEAR</b>		
<b>Foil Set, Clear - (Special Order)</b>		
Foil (7' / 2.13 m) Luff, <b>Clear Anodized</b>	5	7410.30.CLEAR
Foil (2' / 610 mm) Bottom, <b>Clear Anodized</b>	1	7410.33.CLEAR
<b>Foil Screw Set</b>	1	<b>HFG341</b>
Foil Screw	26	HFS1105
<b>Connector Set w/o Bushings</b>	1	<b>HFG599</b>
Connector (7" / 178 mm)	4	—
Connector Bottom (10.75" / 273 mm)	1	—
<b>Connector Bushing Set</b>	1	<b>HFG294</b>
Connector Bushing (Curved / Longer)	10	H-42067
Connector Bushing (Flat / Shorter)	10	H-42068
<b>Connector w/Bushings</b>	1	<b>7410.31</b>
Connector (6.5" / 165 mm)	1	—
Connector Bushing (Curved/Longer)	2	—
Connector Bushing (Flat/Shorter)	2	—
<b>Connector w/Bushings Bottom</b>	1	<b>7410.32</b>
Connector Bottom (10" / 254 mm)	1	—
Connector Bushing (Curved/Longer)	2	—
Connector Bushing (Flat/Shorter)	2	—
<b>Connector Wedge Set</b>	1	<b>HFG298</b>
Connector Wedge	12	H-39625
<b>Feeder Set</b>	1	<b>H-39713</b>
Feeder	1	H-37272B
Feeder Screw	1	HFS1128
Tab	1	H-37282A

Description	Order	Part No.
<b>8 Instruction Manual</b>	1	<b>4416</b>
<b>Prefeeder</b>	1	<b>947</b>
<b>Red Loctite®</b>	2	<b>HFG739</b>
<b>5200 Adhesive Set</b>	1	<b>HFG725</b>
5200 Marine Adhesive Sealant	1	HFG722
Injector	1	HFG200 HFG201
<b>7 mm Single Braid Polyester (55', 16.7 m)</b>	1	<b>HFG594</b>

Description	Order	Part No.
<b>9 Lead Block Kit</b>	1	<b>7404</b>
29 mm Outboard Lead Assembly	3	7403
57 mm Carbo Ratchet Assembly	1	7402
40 mm Carbo Assembly	1	7401
Horn Cleat	1	HCP168
<b>Shackle</b>	3	<b>2110</b>
<b>Halyard Restrainer</b>	1	<b>944</b>
Sheave/SS Inner Race Only	1	944ASSY
Clevis Pin (1/4" x 7/8")	1	HFG467
Bracket-Small	1	HCP393
Cotter Pin (1/16" x 1/2")	1	HFS118
<b>Hex Keys</b>		
2.5 mm	1	HCP1387
3 mm	1	HCP1089
5 mm	1	HFG642

Torlon is a registered trademark of Solvay Advanced Polymers L.L.C.  
Loctite is a trademark of Henkel AG & Company KGaA



# **HARKEN®**

## ***Corporate Headquarters***

N15W24983 Bluemound Rd, Pewaukee, WI 53072 USA  
Telephone: (262) 691-3320 • Fax: (262) 701-5780  
Web: [www.harken.com](http://www.harken.com) • Online Catalog: [www.harkenstore.com](http://www.harkenstore.com)  
Email: [harken@harken.com](mailto:harken@harken.com)

## ***Harken Australia Pty, Ltd.***

1B Green Street, Brookvale, N.S.W. 2100, Australia  
Telephone: (61) 2-8978-8666 • Fax: (61) 2-8978-8667  
Web: [harken.com.au](http://harken.com.au) • Email: [info@harken.com.au](mailto:info@harken.com.au)

## ***Harken France***

ZA Port des Minimes, BP 3064, 17032 La Rochelle Cedex 1, France  
Telephone: (33) 05.46.44.51.20 • Fax: (33) 05.46.44.25.70  
Web: [harken.fr](http://harken.fr) • Email: [info@harken.fr](mailto:info@harken.fr)

## ***Harken Italy S.p.A.***

Via Marco Biagi, 14, 22070 Limido Comasco (CO) Italy  
Telephone: (39) 031.3523511 • Fax: (39) 031.3520031  
Web: [harken.it](http://harken.it) • Email: [info@harken.it](mailto:info@harken.it)

## ***Harken New Zealand, Ltd.***

30-36 Fanshawe Street, P.O. Box 1951, Auckland 1001, New Zealand  
Telephone: (64) 9-303-3744 • Fax: (64) 9-307-7987  
Web: [harken.co.nz](http://harken.co.nz) • Email: [harken@harken.co.nz](mailto:harken@harken.co.nz)

## ***Harken Polska SP ZOO***

ul. Rydygiera 8, budynek 3A, lokal 101, I piętro, 01-793 Warszawa, Poland  
Tel: +48 22 561 93 93 • Fax: +48 22 839 22 75  
Web: [harken.pl](http://harken.pl) • Email: [polska@harken.pl](mailto:polska@harken.pl)

## ***Harken Sweden AB***

Main Office and Harken Brandstore: Västmannagatan 81B  
SE-113 26 Stockholm Sweden  
Telephone: (46) 0303 61875 • Fax: (46) 0303 61876  
Mailing address: Harken Sweden AB, Box 64, SE -440 30 Marstrand  
Web: [harken.se](http://harken.se) • Email: [harken@harken.se](mailto:harken@harken.se)

## ***Harken UK, Ltd.***

Bearing House, Ampress Lane, Lymington, Hampshire S041 8LW, England  
Telephone: (44) 01590-689122 • Fax: (44) 01590-610274  
Web: [harken.co.uk](http://harken.co.uk) • Email: [enquiries@harken.co.uk](mailto:enquiries@harken.co.uk)

**Please visit: <http://www.harken.com/locator.aspx>  
to locate Harken dealers and distributors**