



HARKEN[®]

MKIV

Jib Reefing & Furling Installation Manual

Unit 3



WARNING! Strictly follow all instructions to avoid an accident, damage to your vessel, personal injury or death. See www.harken.com for additional safety information.

Table of Contents

Preassembly

Parts	4-5
Tools	5
Dimensions/Sailmaker's Instructions	6
Toggle Deductions/Stay Into Foil Options	7
Top Foil Length	8
Short Top Foil	9
Foil Length	10

Assembly

Foils/Connectors	11 - 17
Halyard Swivel	17
Drum Assembly	18
Rod Rigging	19
Turnbuckle	20
Toggle	20 - 21
Final	22 - 23

Commissioning

Turnbuckle	24
Line to Cockpit	25
Halyard Swivel Height/Angle	26 - 27
Halyard Restrainer/Tension	27

Operation

Halyard/Headstay Tension	28
Raise Sails	29
Furl/Reef	29 - 30
Secure Sail	30
Race Conversion	31

Maintenance

Clean	32
Inspect	32
Replace Line	32
Storage	32
Remove Furler	32

Troubleshooting

Warranty

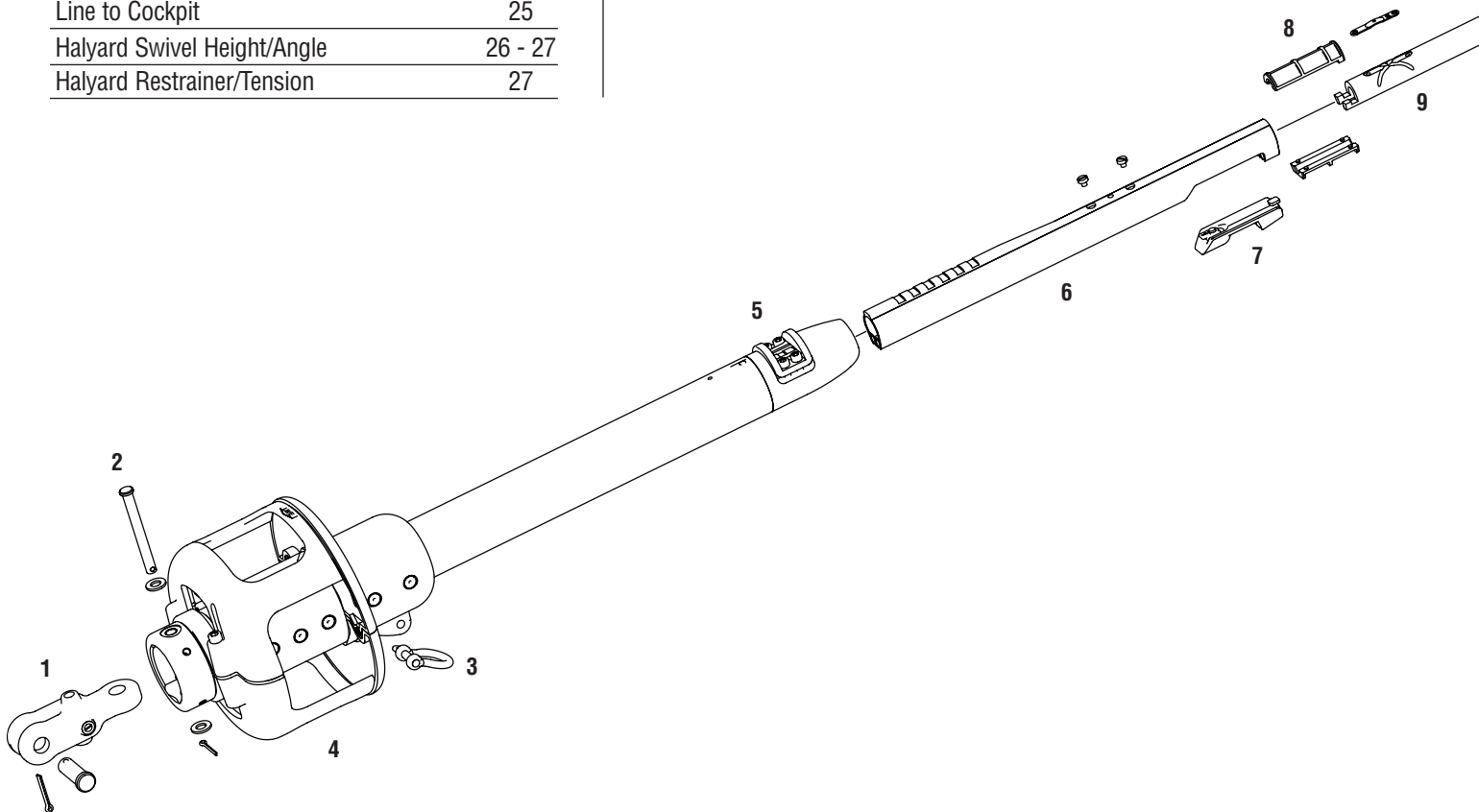

Parts Descriptions

- 1) Toggle Assembly
- 2) Crosspin
- 3) Shackles
- 4) Drum Assembly

- 5) Foil Clamp
- 6) 2' (610mm) Bottom Foil
- 7) Feeder
- 8) Connector Bushing

- 9) Bottom Connector
- 10) 7' (2.13m) Foil
- 11) Connector Screws
- 12) Connector Wedge

- 13) Connector
- 14) Halyard Swivel
- 15) Trim Cap
- 16) Trim Cap Screws

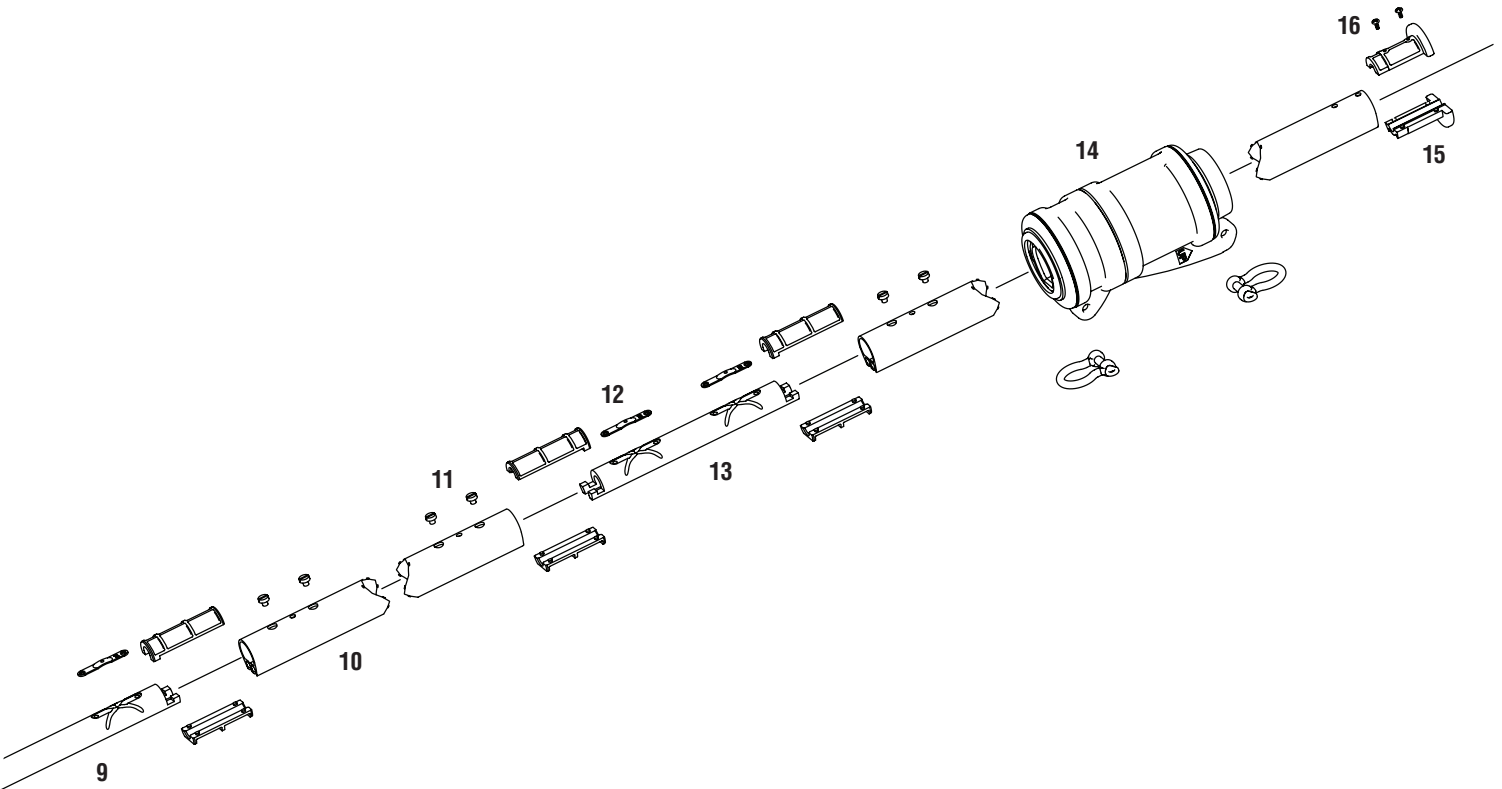

Size Check

1. Check headstay and clevis pin dimensions in chart below.

WARNING! Harken does not recommend drilling boat's chainplate or toggle as this may result in rig failure which will cause an accident, damage to your vessel, personal injury or death. See www.harken.com for additional safety information.

- 2. Harken does not recommend drilling boat's chainplate or toggle. In some cases bushings are available to fit boats with smaller clevis pin sizes.
- 3. Will drum fit on bow? See page 6. If necessary, use an additional toggle to slightly raise unit. To clear anchor use a Harken Long Link Plate which can be cut to various lengths.

Sizing Check			
Unit Part No.	Description	Wire Sizes	
7413.10	MKIV Unit 3	7/16", 1/2"	11mm, 12mm
		Rod Sizes	
		-22, -30	9.53mm, 11.10mm
Toggle Part No.	Description	Chainplate	Clevis Pin Size
7413.20 3/4	Eye/jaw reversible	3/4"	19.1mm
7413.20 7/8	Eye/jaw reversible	7/8"	22.2mm
7313.21 3/4	Long link plate w/toggle	3/4"	19.1mm
7313.21 7/8	Long link plate w/toggle	7/8"	22.2mm

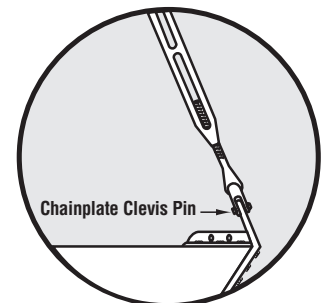



Main Components

Part No.	Quantity	Description
HFG293	1	Drum assembly with clamp
H-39392	1	Halyard swivel

Foils (Standard Package)

Part No.	Quantity	Description
7413.30	10	7'(2.13m) Foil
7413.33	1	2'(610mm) Bottom foil (shipped in drum box)

Tools

Quantity	Description
1 Each	3, 4, 6, 10mm Allen wrenches

Other Components

Part No.	Quantity	Description
7413.31	9	9.75" (248mm) Connector
7413.32	1	14" (356mm) Bottom connector
HFG297	1	Connector bushing set (20 each H-42073/H-42074)
HFG324	1	Plastic connector wedge set (22 39487)
HFG349	1	Foil screw set (46 HFS1106)
HFG682	1	Trim cap set (H-39751/H-39752)
HFG672	1	Trim cap screw set (3-HFS1127)
947	1	Prefeeder
H-39756	1	Feeder with screw and tab
2124	3	10mm Bow shackle
HFG725	1	Injector, 1 oz. 5200 Adhesive (HFG722)

Line Diameter/Length

Furling line is not included with furling unit. Purchase 7/16" (12mm) low stretch Dacron double braid. The length of the line should be equal to the length of the boat plus the length of the foot of the largest genoa plus 6' (2m).



Line Not Included

Toggles

1. Harken toggle assembly required. Sold separately.
2. Mating turnbuckle components must be purchased separately.
3. Headstay may require cutting and shortening to fit Harken toggle. Headstay may remain uncut by replacing lower stud of turnbuckle with stud/eye thus eliminating extra toggle.
4. Rod rigging requires Harken rod adapter stud.



WARNING! Headstay condition should be checked by a professional rigger before reusing. Wire that is old or damaged may break suddenly causing an accident, damage to your vessel, personal injury or death. See www.harken.com for additional safety information.

**ALL UNITS
Harken Toggle
(Sold Separately)**



Eye/Jaw Toggle
7413.20 3/4
7413.20 7/8

Long Link Plate w/Toggle*



7313.21 3/4
7313.21 7/8

**ROD RIGGING
Harken Rod Adapter
Stud Required
(Sold Separately)**



7426 -22
7427 -30
Rod Adapter Stud

*Requires drum assembly with four threaded holes in base. See page 21.

Tools You Will Need



1. Long tape measure	6. Side cutters	11. Center punch
2. Short tape measure	7. Rat-tail file	12. Rigging or black tape
3. Power drill	8. Allen wrenches (provided)	13. Scissors
4. Drill bit – 5/32" (4mm)	9. Slotted/phillips screwdrivers	14. Metal straight edge
5. Hacksaw	10. Needle-nose pliers	15. Hammer

Adhesive Alert

MKIV Furlers are shipped with 3M 5200 adhesive. Use adhesives on dry connectors and foils using the special injection system described in the assembly section. Parts may immediately be exposed to rain. Cure is best at 70 F (22C) with 50% humidity. Do not apply at temperatures below 40 F (5C) and above 100F (38C).

Although adhesive has not cured it will remain in place on foil joints whether they are left on the ground or raised up on boat. Foils can be raised immediately after assembly and sails fitted.

Note: A small amount of adhesive may bulge out of injection ports. If possible let system sit for a couple days before sailing. If adhesive gets on sails remove using acetone. For faster-curing adhesive, purchase 4200 Fast Cure.

Note: Damaged foils can be repaired. Use a hand-held propane torch to heat joints until foils can be pulled apart.

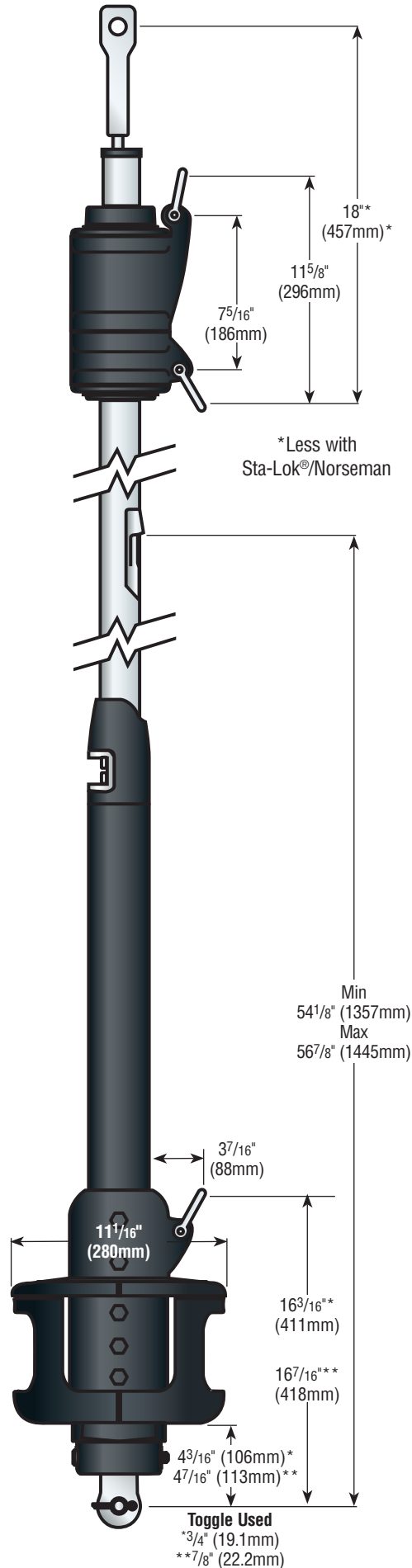

Luff Length

Note offsets above and below sail.

A shorter luff may be required if a halyard restrainer is necessary (page 27) or a toggle or long toggle assembly is used to raise drum. If luff of sail is not long enough to put halyard swivel near top of headstay foil, a pendant must be added, (see page 26).

Tack Setback

Note setback for tack shackle and cut sail accordingly.

Luff Tape Size

Unit 3 requires #6 (6/32" or 5mm) luff tape.

Luff Tape Length

Note feeder height and extend bottom of luff tape downward so it is below feeder. This will prevent luff tape from catching in feeder as sail is lowered.

Tack and Head Shackles

Make sure tack and head shackles fit sail rings. Minimum inside dimensions of standard head and tack shackles are:

- (A) 1 7/8" (48mm)
- (B) 1 3/16" (21mm)

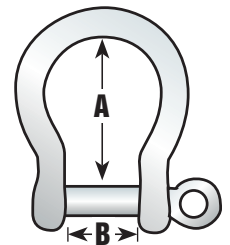

Sun cover

Sun covers may be installed on either side of sail. Be sure to match other sails in the customer's inventory.



Note: If a long link plate is used, add the following dimensions to feeder, shackle and drum height (based on whether plate is used full-length or shortened to one of five hole positions). Do not add to halyard swivel or top terminal dimensions.

3/4" (19.1mm) Clevis Pin	Add 19 9/16" to 10 11/16" (497mm to 271mm)
7/8" (22.2mm) Clevis Pin	Add 19 7/8" to 11" (505mm to 279mm)

Use dimensions of Harken toggle below to build stay to correct length.

Tip: Turnbuckles should be 1/2 to 2/3 open to allow shortening for new wire stretch and for fine-tuning mast rake.

Diagram illustrating Fork Attachment and Tang Attachment. Labels include Crosspin, Fork Attachment, and Tang Attachment. A note states: "For tang-down installations, switch plugs to this position."

Most boats have a chainplate with single tang. If boat has two plates forming a jaw, reverse eye/jaw toggle so eye is down.

Important: Remove black plastic caps and install them so crosspin will be 90 degrees to lower clevis pin.

Clevis Pin	Pin-to-Pin Length
3/4" (19.1mm)	5" (127mm)
7/8" (22.2mm)	5 1/2" (140mm)

Diagram showing a toggle assembly with dimensions: 5" (127mm) or 5 1/2" (140mm) for the main length, and *3 1/4" (83mm) and **3 7/8" (98mm) for the lower section.

Long Link Plate w/Toggle
 *3/4" (19.1mm) Clevis Pin
 **7/8" (22.2mm) Clevis Pin

Options for Snaking Stay into Foils

1. Swage stud at end of wire.
2. Open end of wire and install Norseman or Sta-Lok® stud after foil is assembled.
3. Rod adapter nosepiece for Harken rod adapter stud: Threaded nosepiece must have a positive lock of as well as adhesive. Use Harken stud with cotter pins (see page 19).

WARNING! Using a threaded nosepiece with only adhesive at the upper rod eye terminal may result in headstay system failure which can cause an accident, damage to your vessel, personal injury or death. See www.harken.com for additional safety information.



Measure A and add to this chart and length chart below		
	Inches	mm
A		
B	1	25
E	24	610
F	31	787
G		
Total A+B+E+F+G		

Make sure upper measurement points of A and Pin-to-Pin are the same.

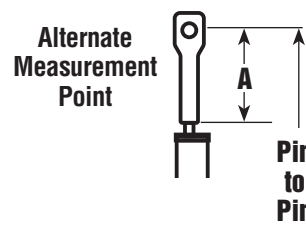

TOP FOIL LENGTH WORKSHEET

1	Pin-to-Pin Length	
2	Subtract ABEFG	-
3	Result (Pin-to-Pin - ABEFG)	
4	Subtract D	-
To find "D" pick number from chart below that is closest to, but not greater than total from step 3.		
	Inches	mm
	7 x 84 = 588	7 x 2133.6 = 14935.2
	8 x 84 = 672	8 x 2133.6 = 17068.8
	9 x 84 = 756	9 x 2133.6 = 19202.4
	10 x 84 = 840	10 x 2133.6 = 21336
	11 x 84 = 924	11 x 2133.6 = 23470
Example-If result from Step 3 is:		
800 inches "D" = 756 inches 20,000mm "D" = 19,202mm		
5	Result (C) Top Foil Length	

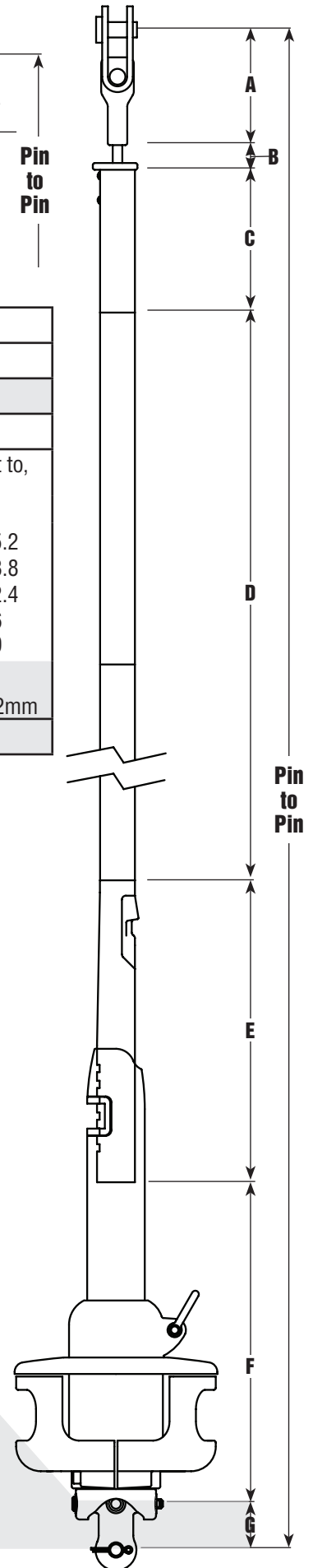

Length Check

After completing worksheet above fill in A, C, D and G below. Add "A" through "G" to confirm total equals your pin-to-pin measurement.

Length Chart			
Dimensions	Inches	mm	
A Center of Pin to Bottom of Terminal			
B Bottom of Terminal to Top of Foil	1	25	
C Top Foil Length			
D Number of Foils _____ x 84" (2133.6mm)			
E Bottom Foil	24	610	
F Bottom of Foil to Crosspin	31	787	
G Crosspin to Clevis Pin			
Pin-to-Pin Length			

G Toggle Distance from Lower Clevis Pin to Crosspin Hole					
Toggle Part No.	Type	Clevis Pin		G Distance	
7413.20 3/4	Eye/Jaw Reversible	3/4"	19.1mm	2.5"	63.5mm
7313.20 7/8	Eye/Jaw Reversible	7/8"	22.2mm	2.75"	70mm
7313.21 3/4	Long Link Plate w/Toggle	3/4"	19.1mm	22"	559mm
7313.21 7/8	Long Link Plate w/Toggle	7/8"	22.2mm	22 ⁵ / ₈ "	575mm

Note: If long link plate is shortened, dimension must be changed or foil will be too short. Measure distance from crosspin down to where clevis pin attaches toggle to boat and use this dimension in G above.

If top foil is shorter than 93/4" (248mm), use one of the following special techniques to ensure sufficient bearing surface for the foil in the area of the halyard swivel.



93/4" (248mm) No special treatment required.



95/8" - 71/8" (244 - 181mm) Do not use plastic bushing above top connector.



7" - 51/2" (178 - 140mm) Do not use plastic bushing above top connector. Shorten top of connector and if necessary shorten trim cap.



53/8" - 4" (137 - 102mm) Do not use plastic bushing above top connector. Cut connector right at cross formed by glue dispersion channels. Use single foil screw in top foil only.



31/2" - 11/2" (89 - 38mm) Shorten top foil and adjoining full length foil so two screws are used to assemble joint instead of four. Do not use plastic bushings above top connector.

Top Foil Length from Worksheet	1. Initial top foil cut length	2. Cut through middle hole in top foil.*	3. Shorten full length adjoining foil by cutting through middle hole.*	4. Shorten connector	5. Shorten trim cap
		Resulting Top Foil Length		Length	
31/2" (89mm)	69/16" (167mm)	5" (127mm)		47/8" (124mm)	No
3" (76mm)	61/16" (154mm)	41/2" (114mm)		47/8" (124mm)	No
21/2" (64mm)	69/16" (167mm)	4" (102mm)		47/8" (124mm)	No
2" (51mm)	51/16" (129mm)	31/2" (89mm)		43/8" (111mm)	Yes
11/2" (38mm)	49/16" (116mm)	3" (76mm)		33/4" (95mm)	Yes



*To allow for saw cut, position blade so upper half of middle hole is preserved.



Under 11/2" (38mm) Eliminate top foil and run foil higher in drum assembly.

Confirm foil length by laying foils alongside stay with turnbuckle components.

Pull stay out so it is straight. Attach Harken toggle to bottom of stay. Make sure toggle straps are straight. Adjust turnbuckle so that length of stay with Harken toggle will fit boat. Ideally, turnbuckle will be half to two-thirds open to allow for rig adjustment.

Line up drum assembly so holes below drum line up with holes in Harken toggle. Make sure toggle is tensioned when measuring.



Line up bottom foil so foil clamp is just above or below center of notches in bottom foil.

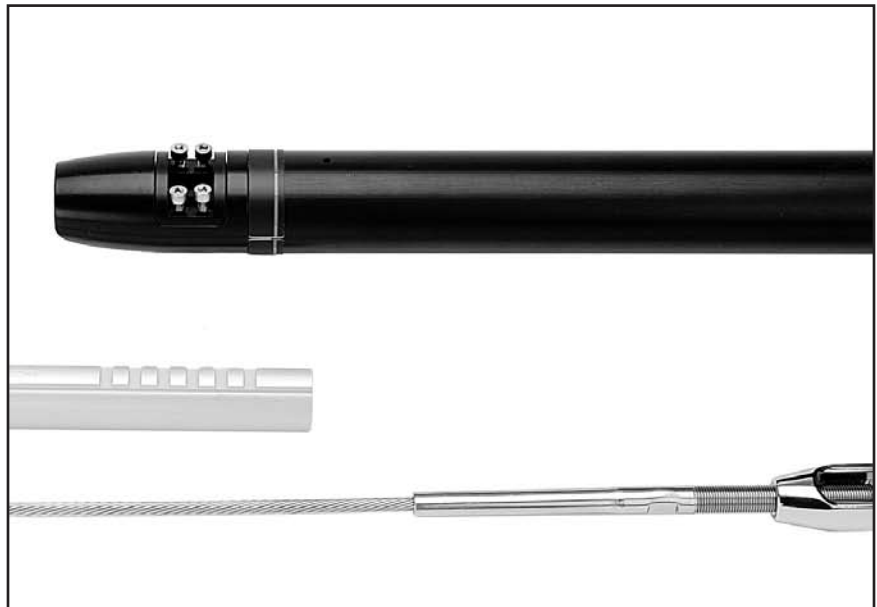

Note: Position top foil so that with top cap the foil will ride 1" (25mm) below terminal. If wire fitting at top of stay is swage, foil must ride just below shoulder of swage. Mark cut line on foil. Wrap tape around foil as a guide so cut is straight.



Cut foil to length using hacksaw.



Deburr inside edge using rat-tail file.

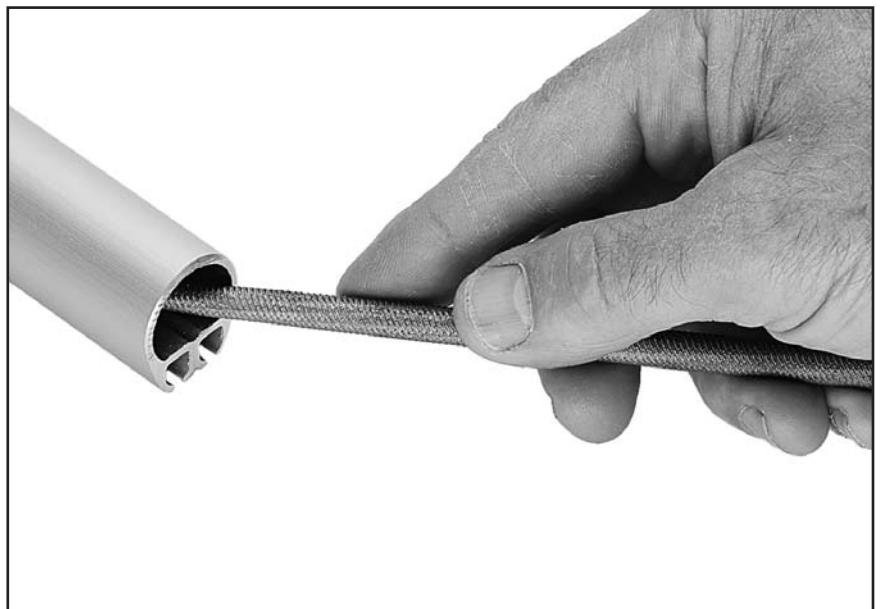

Prepare top foil for drilling.

Tip: Mark top foil to distinguish from cutoff piece.

Scribe line on top of foil to mark drill holes. Lay top foil alongside cutoff piece and use a flat metal object (i.e. metal ruler) to scribe top line of foil.

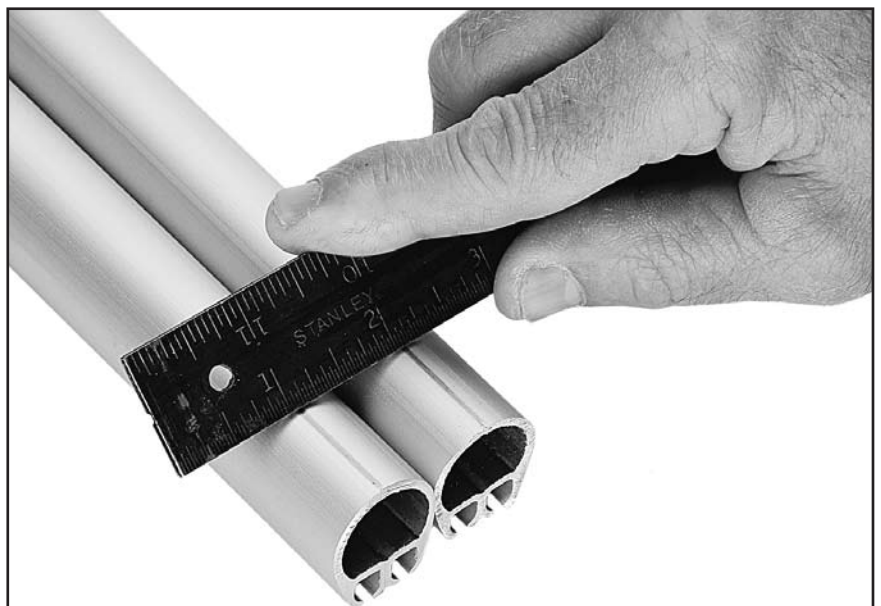

Cut out template at right. Line up template with top of foil and scribed line. Tape in place. Use center punch to mark holes. Check center punch marks to confirm they are 3/8" (10mm) and 1 3/8" (35mm) from top of foil.

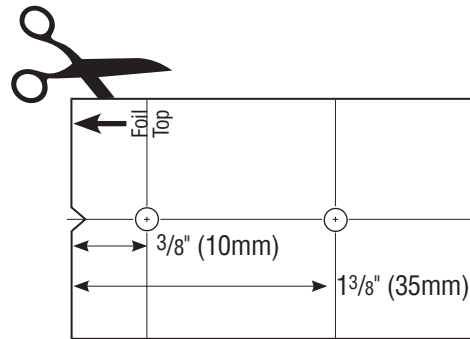

Drill two (2) 5/32" (4mm) holes for trim cap.



Lay top foil in line with others. Slide stay into top foil and down line of foils or slide each foil up stay.



Install trim cap. Place each side over wire.

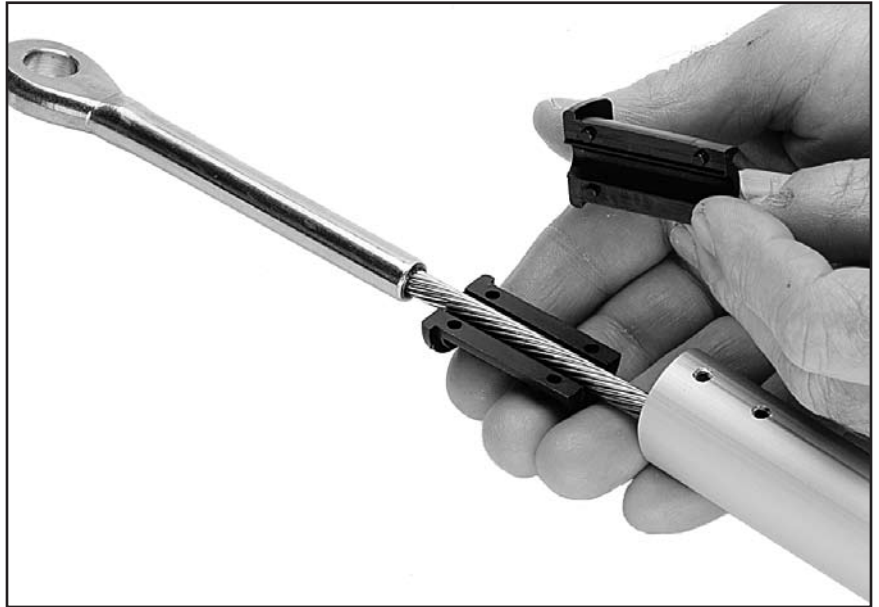

Push trim cap into foil to start, then tap in using hammer.
Install trim cap screws.



Place halves of plastic bushings on stay so hooked part of longer section faces out.
Tip: With foil screw holes up as shown below, place longer half of bushing with hook on upper half.



Slip 9³/₄" (248mm) connector on wire, mating hook of plastic bushing with connector.



Loading Injector with Adhesive

Tip: In cooler weather, keep sealed adhesive in pocket to keep warm. Use instructions below to fill injector less than half way; you will only use a small amount of adhesive. Refill if needed but do not keep open sealant for long periods. Use adhesive within 3 hours.

Use cap of adhesive to break seal. Remove injector tip cap and plunger. Hold injector at an angle with applicator tip facing down. Squeeze adhesive into tube so lower half of injector is full as shown. Keep tip free of sealant to let air inside.

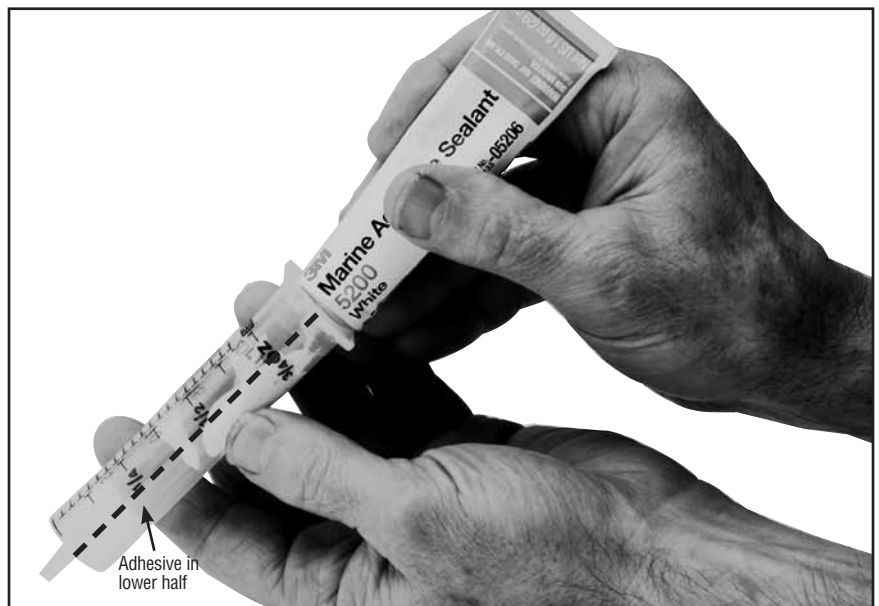

Start plunger into injector and immediately hold upright so plunger is down and applicator tip is up.

As sealant runs down towards plunger an air pocket will form near tip. Push plunger to evacuate air. You are now ready to begin injecting adhesive.

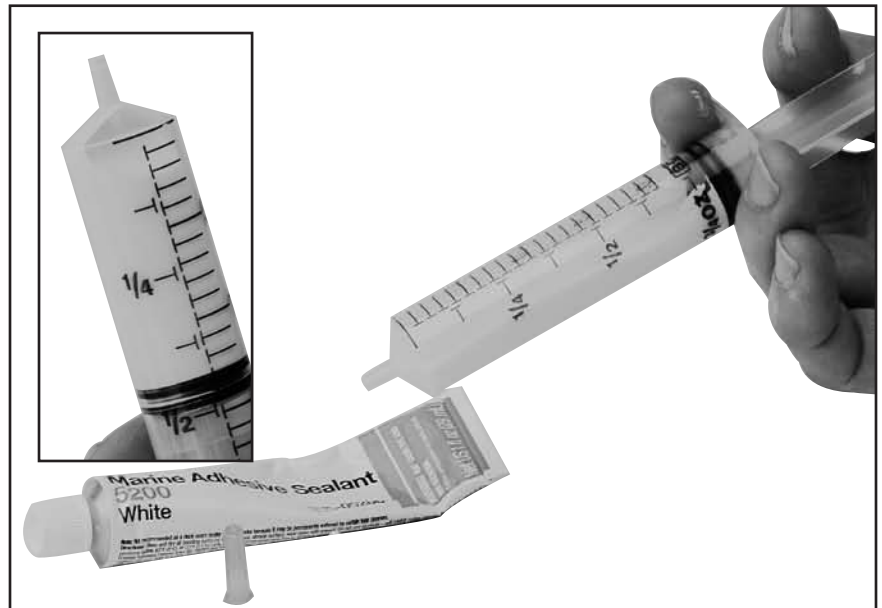

Put a drop of adhesive into screw holes.



Hold plastic wedge in place with thumb as you insert into foil. Line foil holes with connector screw holes.



Inject only a small amount of adhesive into middle hole. Unit 3 will only take 1 to 1 1/4ml of a graduation mark.

Tip: When you see a small amount of adhesive enter one screw hole, stop. You have applied enough adhesive.

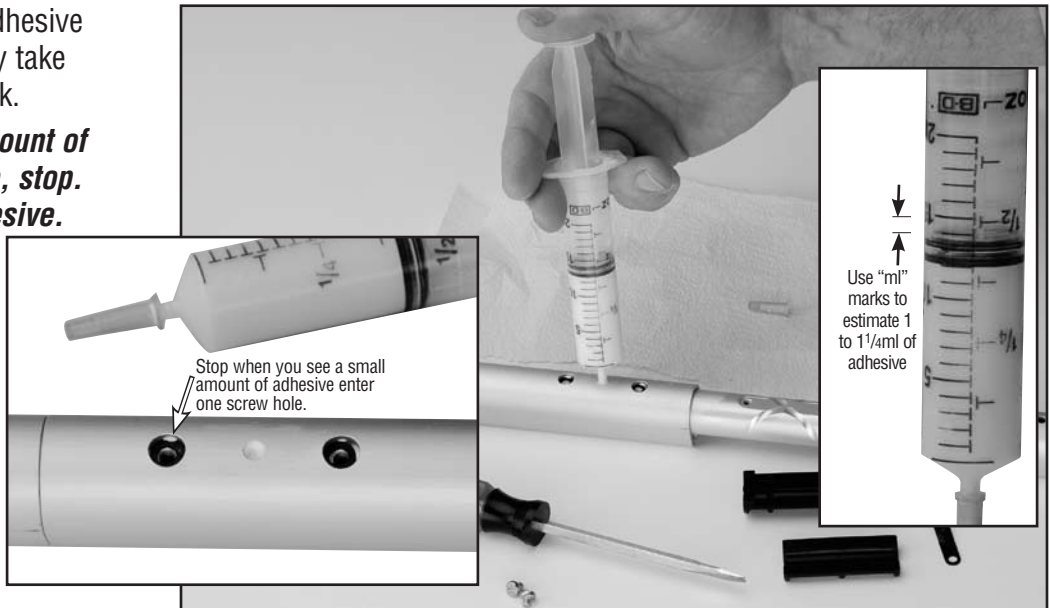

Tighten screws into connector holes. Make sure a drop of adhesive entered each screw hole. If not, apply to screw.



Use bushings, connector, wedge and adhesive in other screw hole and insert into other foil. Use 1 to 1 1/4ml of adhesive.



Continue installing connectors and wedges. Make sure to use adhesive in screw holes.

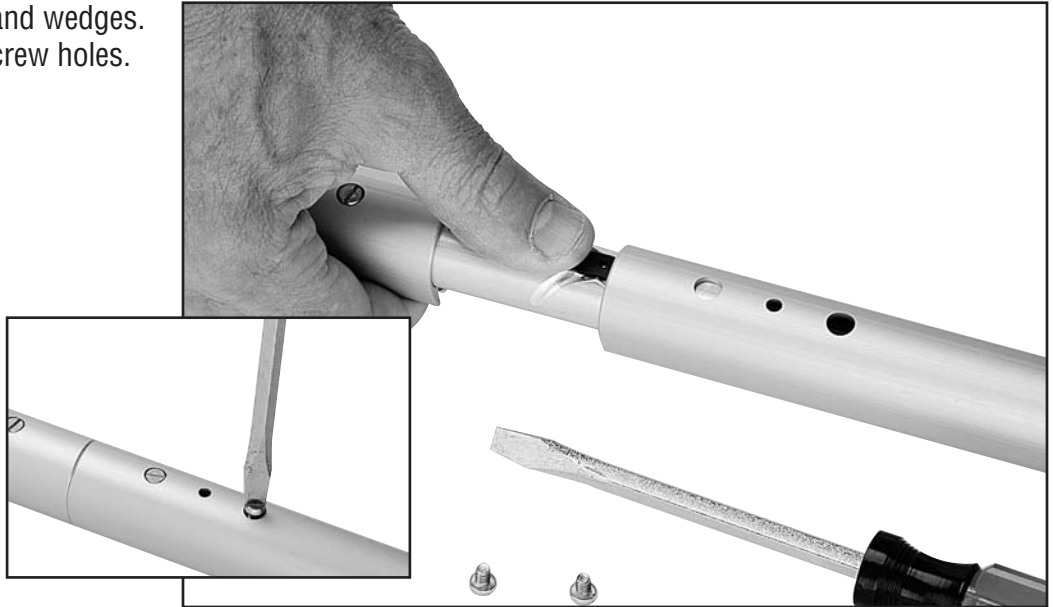

Continue assembly. Use 14" (356mm) bottom connector to assemble bottom foil.

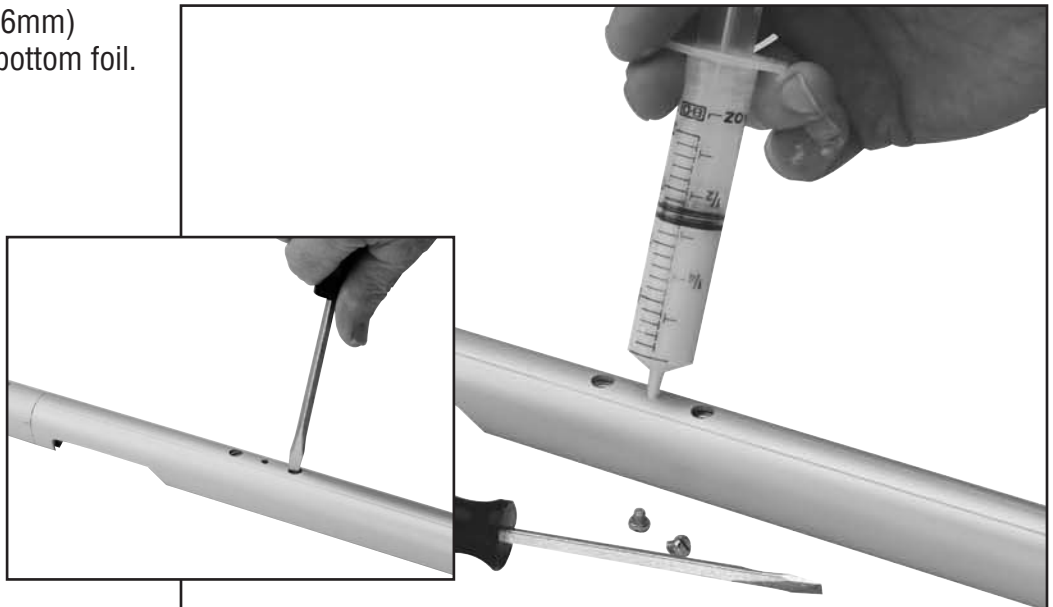

Slide halyard swivel onto foil above feeder window. Make sure taller "half" is up as shown.



Loosen foil clamp screws at top of drum assembly.



Slide drum assembly onto foils.
Tip: Face clamp downward so it clears foil notches during installation.



G
N
G
G
R
I
G
G
I
N
G
R
O
D
R
O
D

Apply a few drops of red Loctite® to threads of nosepiece. Screw main threaded stud portion onto bronze nosepiece until flats align with two cotter pin holes in terminal body.

Tip: Turn nosepiece completely into threaded stud portion. Flats will be close and may only require a small half turn to align with cotter pin holes.



Insert two cotter pins and spread. Clean excess Loctite® from terminal body using special care to ensure that there is no red Loctite® on threaded stud.

Assemble turnbuckle and attach Harken toggle.

Note: If using Sta-Lok® or Norseman® stud, you must use a washer above stud as shown below.

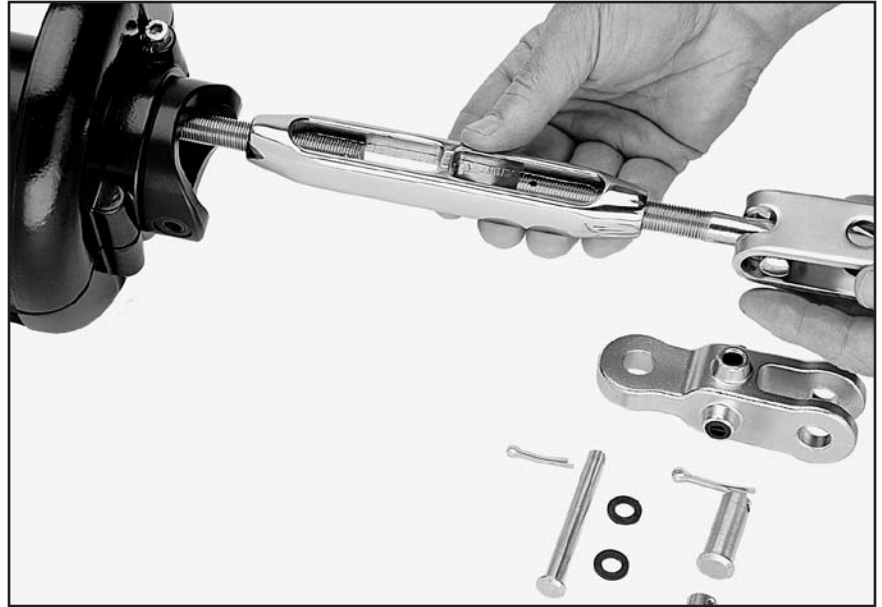
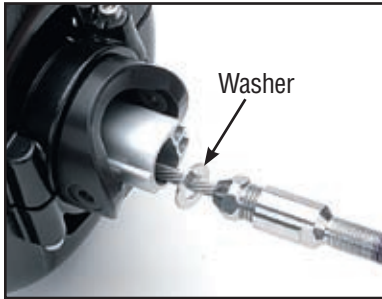

Assembly

Attach Toggle/Long Link Plate

Make sure drum assembly has four threaded holes in base.

Determine height of link plates to provide anchor clearance and cut to length.

Cut at scribe mark. Deburr edges.

Connect eye to toggle jaw using special clevis pin. Secure using cotter pin.

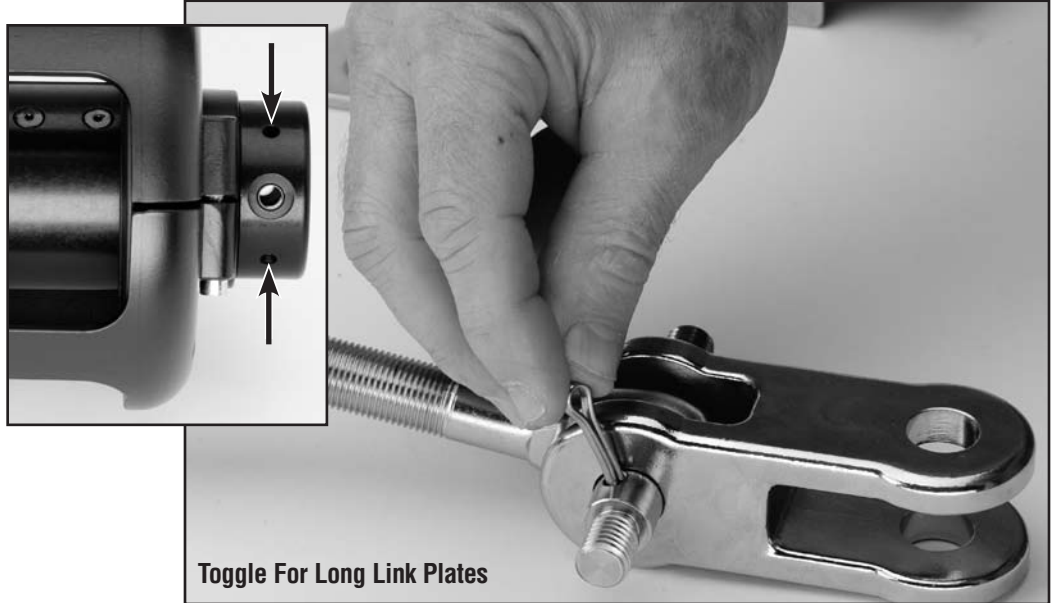

Fasten one long link plate to drum assembly using fasteners. Use blue Loctite® on screws.



Fasten second long link plate to drum assembly and secure to clevis pin using locknuts.



WARNING! Stay must attach to toggle. Do not attach stay to crosspin at drum assembly because crosspin and plates may fatigue and break causing an accident, damage to your vessel, personal injury or death. See www.harken.com for additional safety information.

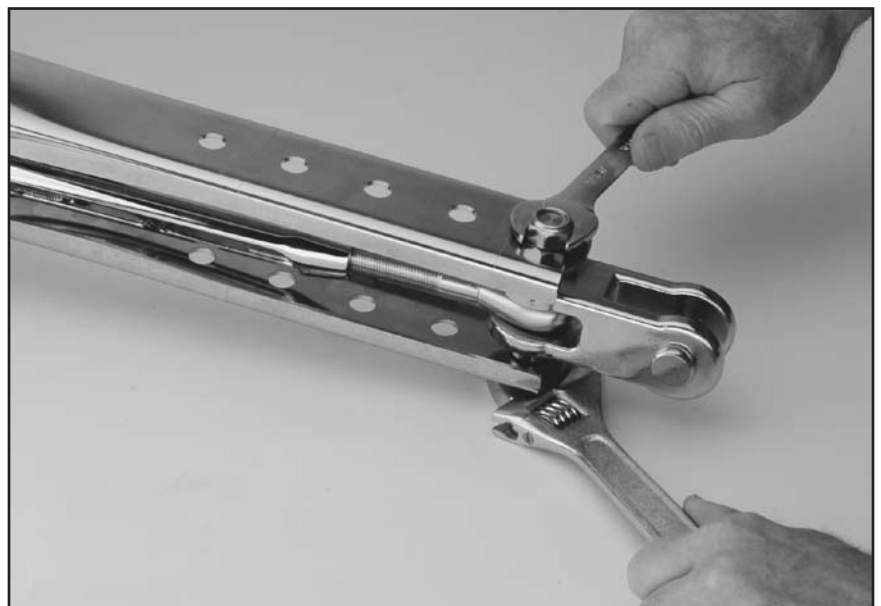

If stay length is set, use side cutters or needle-nose pliers to bend cotter pin to secure turnbuckle.



Slide lower drum assembly over turnbuckle and attach using long crosspin. Use plastic washers provided.

Important: Crosspin must be at 90 degrees to clevis pin that attaches unit to boat.



WARNING! Crosspin must be 90 degrees to clevis pin that attaches unit to boat. If pins run same direction toggle will fatigue and could break suddenly causing an accident, damage to your vessel, personal injury or death. See www.harken.com for additional safety information.



Check foil height at top, set and secure using Allen wrench.

See tip on next page.



Tip: Do not remove foil clamp screws to adjust foil. Loosen screws, hold foils and bring clamp away from foils. Adjust and reclamp.



Slide halyard swivel above feeder. Place feeder in foil recess. Push screw down so tab catches under foil. Tighten screw.

Note: Screw will turn with some difficulty. It is plastic coated to prevent loosening due to vibration.

Important—When removing screw, loosen no more than one full turn. Slide screw up and remove feeder.

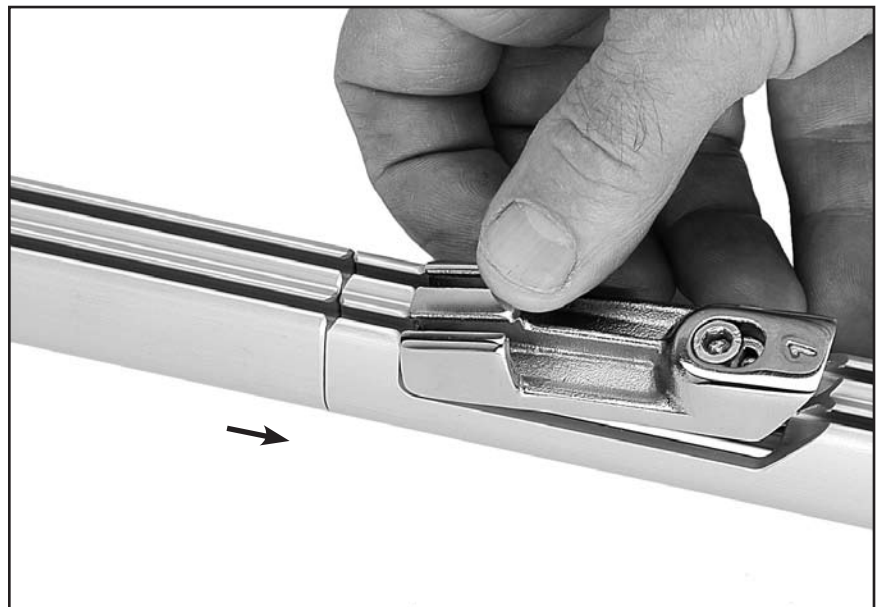

Commissioning

Turnbuckle on Boat

Have extra cotter pins on hand to replace used ones at base of unit and for turnbuckle.

Hold foils and loosen drum assembly screws until you can pull clamp out to lower foils.

Lower foils.

Remove crosspin holding drum assembly to turnbuckle.

Raise drum assembly and use halyard to lift and hold it about 5' (1.5m). Raise foils using second halyard and secure. **Allow room above for turnbuckle take up.**



WARNING!: To avoid injury, make sure drum assembly and foils are securely lifted using a halyard before adjusting turnbuckle. Failure to do so may cause an accident, damage to your vessel, personal injury or death. See www.harken.com for additional safety information.

Adjust turnbuckle.

Replace used cotter pins. Lower drum assembly and install clevis pin and new cotter pin.

Lift foils so top is 1" (25mm) below upper terminal.



WARNING!: Stay must attach to toggle. Do not attach stay to crosspin at drum assembly because crosspin and plates may fatigue and break causing an accident, damage to your vessel, personal injury or death. See www.harken.com for additional safety information.

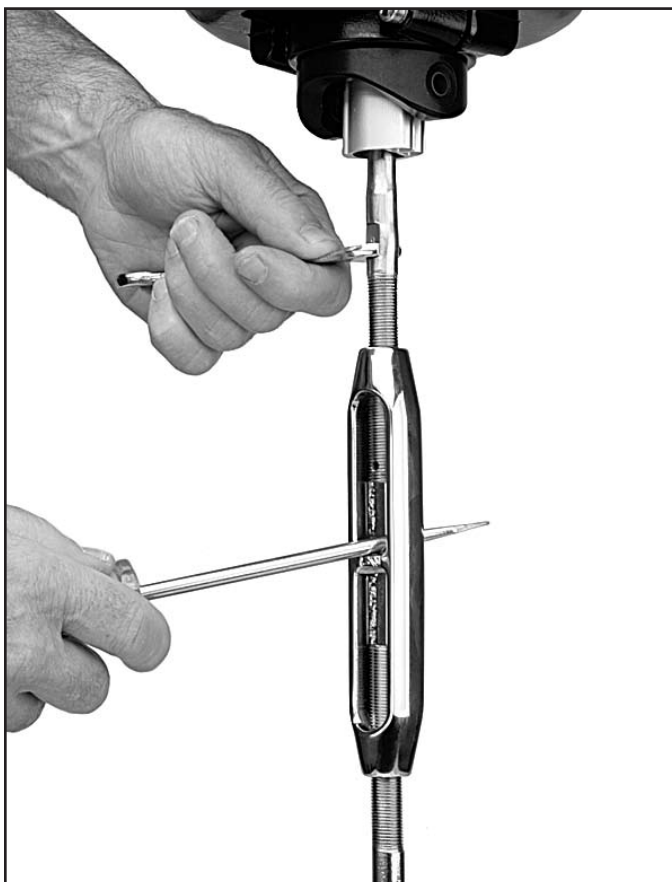
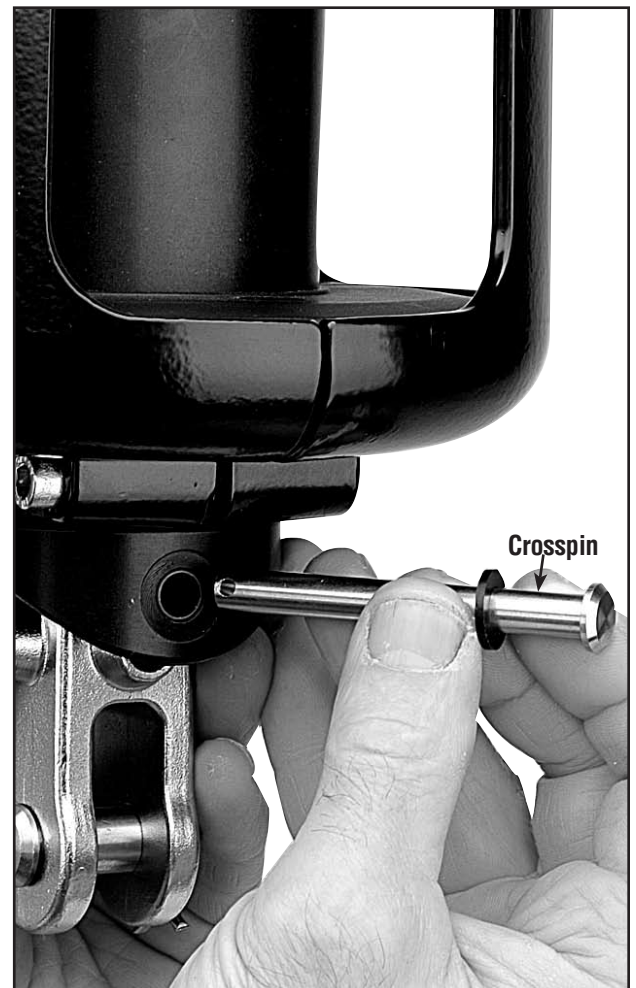

Important: When reinstalling crosspin, pin must be at 90 degrees to clevis pin that attaches unit to boat.



Run line through enclosed window in guard and into hole in bottom plate of spool. Tie a small overhand knot and pull it up under drum assembly.



WARNING! If line is led through opening between two enclosed windows it can ride above lineguard and jam furler. This can cause an accident, damage to your vessel, personal injury or death. See www.harken.com for additional safety information.

Note location of sun cover. Charge system by rotating furler to wrap line on drum.

Tip: Sun cover to starboard—turn clockwise to charge. Sun cover to port—turn counter-clockwise. Tension line while charging.

Mount Lead Blocks

Furling line can be led down either side of boat. If boat is in slip, consider mounting opposite dock.

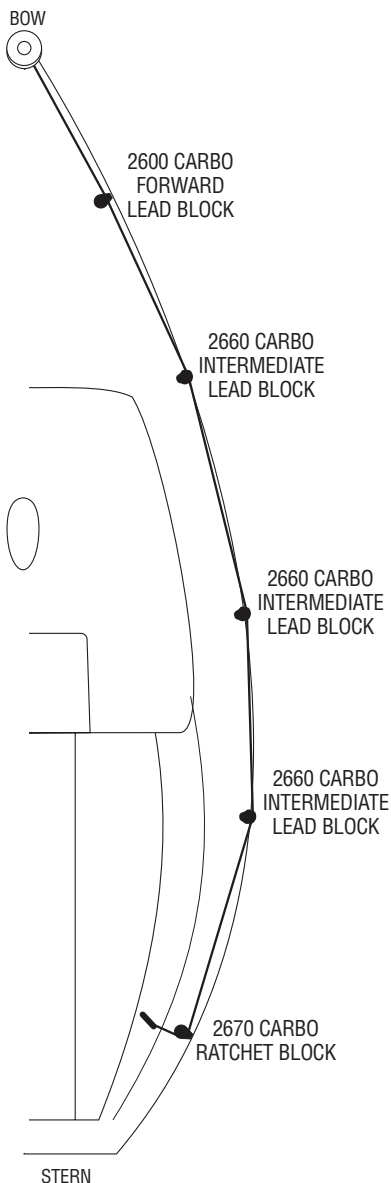

2600 Forward Lead Block

Position 2600 Forward Stanchion Block so line enters drum at right angles to headstay and centers vertically in opening. Install so line is inside stanchion.

Correct block position is critical to even line spooling and ease of furling.

2600 57mm Carbo Intermediate Lead Blocks

Install 2600 Intermediate Lead Blocks so line is inside stanchions.

Number and placement of leads depends on boat length and number/configuration of stanchions.

2670 75mm Carbo Ratchet Block

Mount 2670 Carbo Ratchet Block as furthest-aft lead to prevent line overrides in drum when unfurling. Position ratchet block so line turns at least 90°.

Install so line is inside stanchion.

Lead line through block so ratchet makes clicking sound when pulling line to furl sail.

Tip: Make sure ratchet switch is in "ON" position. If there is no clicking sound, lead line through block in opposite direction.

Lead line to Furling Line Cleat in cockpit.

Furling Line Cleat

Install so line is angled as shown.

Note: As furling line lead changes, make sure line doesn't chafe against line guard. Rotate line guard if necessary.

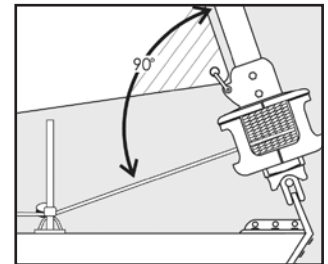

Furling line must enter drum at right angle to headstay.

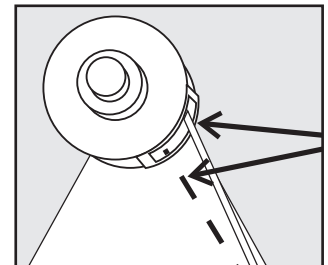

Furling line lead changes as amount of furling line on drum changes.

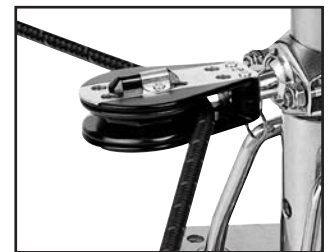

061 stanchion mount bases provide an ideal attachment for furling line lead blocks. Ball joint socket accepts most small boat swivel blocks, including ratchet blocks.

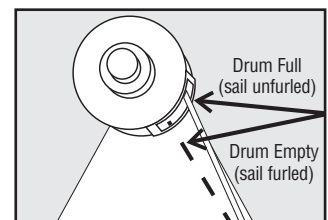

Halyard Wrap

The most serious problem with furling systems occurs when the jib halyard wraps around the headstay foil. Halyard wraps will keep you from furling or unfurling and may cause serious damage to the unit and the halyard.



WARNING!: In severe cases, a halyard wrap can cause loss of control of boat and/or headstay can break suddenly which can cause an accident, damage to your vessel, personal injury or death. See www.harken.com for additional safety information.

To prevent wraps, the halyard must exert a slight pull to the rear. This allows the foils to turn while halyard remains stationary.

Prevent Halyard Wraps



WARNING!: Sail must be fitted to foil length before using to prevent headstay loss which will cause an accident, damage to your vessel, personal injury or death. See www.harken.com for additional safety information.

1. Halyard swivel should be within top 4" (100mm) of foil unless a halyard restrainer is used.
2. Halyard must pull slightly to rear (8 - 10°).
3. Halyard must be snug, but not too tight.

If halyard wraps, do not force unit to turn. Attempt to open sail by carefully furling in and out a little at a time. If sail will unfurl, lower it by releasing jib halyard. Severe halyard wraps can only be cleared by going aloft and freeing halyard.

If sail will not furl or unfurl, try to remove jib sheets and manually wrap sail around headstay.

Testing at dock does not indicate halyard angle is correct. In wave action, halyard may wrap if lead angle is not correct. The 8-10° diverging angle shown at right is critical.

Pendants

If the your sail luff is not long enough to position halyard swivel properly, you must add a pendant. Pendants should be made of plastic-coated wire and be permanently attached so sail height will be correct. Adjustable-length pendants are not acceptable, as they might not be adjusted correctly during a sail change.

1. Raise sail, but do not attach tack shackle.
2. Position halyard swivel correctly near top of headstay.
3. Secure halyard.
4. Tie a piece of rope to sail tack.
5. Lead line through tack shackle on furling drum.
6. Tension sail.
7. Measure distance from tack shackle to sail tack and permanently attach pendant of this length to head of sail.
8. Repeat procedure for every jib in your sail inventory.

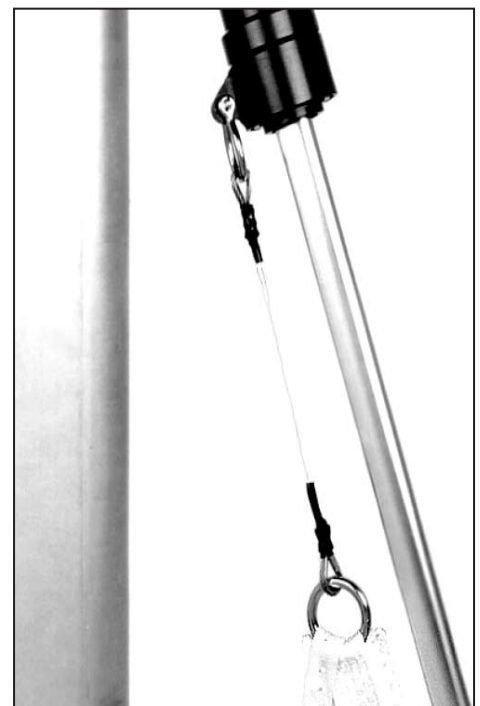
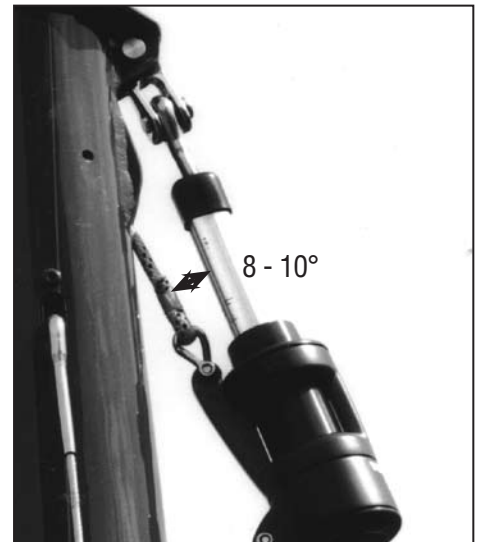
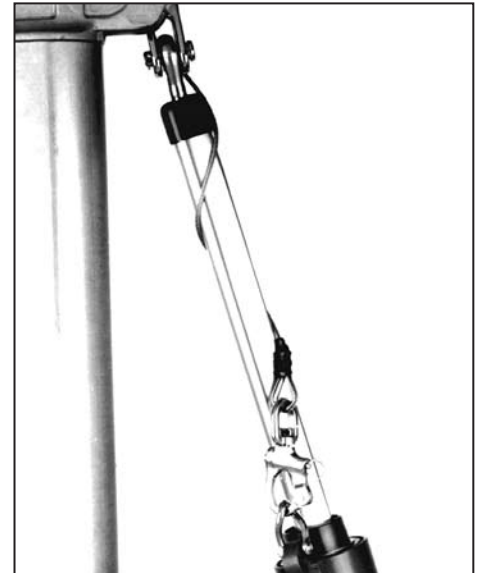

To prevent wraps, jib halyard must pull slightly to rear. On most boats, halyard lead angle is acceptable if halyard swivel is raised to top of foil. On some boats halyard sheaves are located too close to headstay and a halyard restrainer must be used.

Halyard restrainers should be used only when required by masthead geometry. Restrainers tend to limit sail luff length and may cause problems if not installed properly.

If your boat needs a halyard restrainer, use Harken Part No. 945 or 1988. Restrainer should be mounted as high as possible on face of mast. Position restrainer so that foils will not hit it when under load.

The restrainer should deflect halyard as little as possible or you may experience difficulty in tensioning sail luff, friction when furling, and possible damage to foils. To decrease deflection angles, shorten sail luff.

Tip: Boats used in charter service should have a halyard restrainer, regardless of masthead geometry.

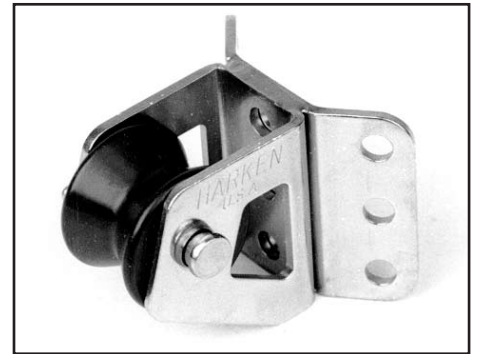

Halyard Tension

The jib halyard should be firm, but not too tight.

Tip: The luff foil system supports sail along its length so halyard tension is used only to shape sails, not to support them. Use enough halyard tension to remove some wrinkles along luff of sail. Do not tension halyard enough to cause vertical wrinkles in luff of sail. Tension to adjust position of draft in sail to suit sailing conditions. Halyard should be firm but not tight. If in doubt, release halyard tension. To protect sail, ease halyard when boat is not in use.



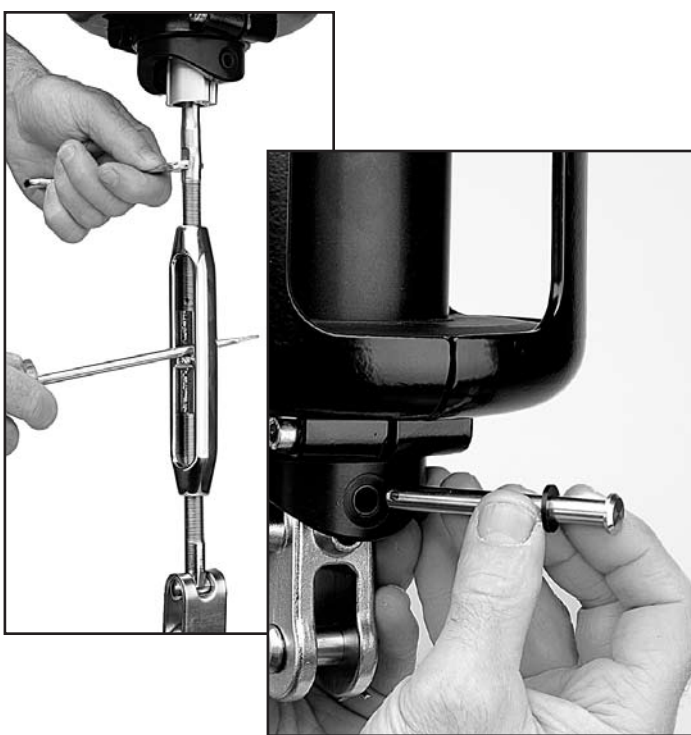
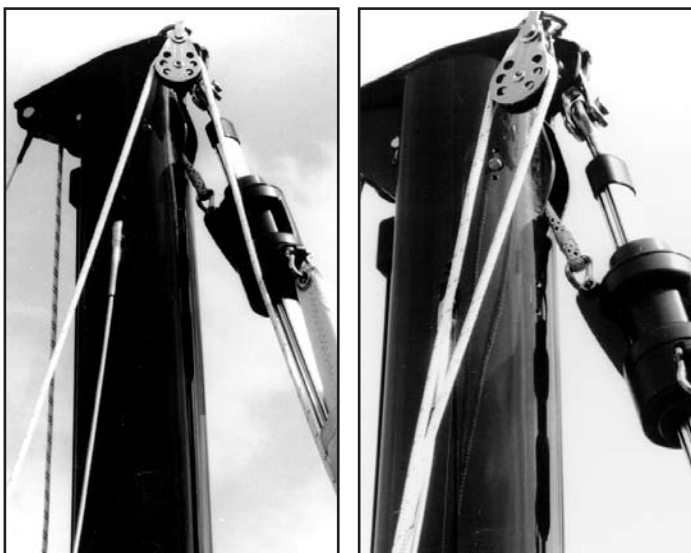

Spinnaker Halyards

Spinnaker halyards occasionally cause problems with furling.



WARNING! In severe cases, spinnaker halyards can jam furler causing loss of control of boat which can cause an accident, damage to your vessel, personal injury or death. See www.harken.com for additional safety information.

On many boats it will not be possible to attach spinnaker halyard to bow pulpit or it may be "sucked" into jib when furling.

On some boats the spinnaker halyard lays across headstay and will catch on halyard swivel, foils or jib halyard. To prevent problems it may be necessary to install a masthead bail to move spinnaker halyard block forward and to one side.

Boats with external halyards may find it necessary to flip both ends of spinnaker halyard behind spreaders to prevent fouling with furling system.

Headstay Tension

A furling system will work best if headstay is tight. A loose headstay is difficult to rotate and can cause unusual wear on foil joints.

To adjust headstay tension, remove sail and furling line from unit and follow instructions on Page 24.

Tip: Before adjusting headstay tension, slack mainsheet and vang.

Backstay Adjusters

Backstay adjusters allow headstay tension to be varied to change sail shape to match conditions. They permit a very tight headstay to be eased when boat is not in use. For best performance, consider adding a backstay adjuster; either a block and tackle, a mechanical adjuster like those offered by Harken, or a hydraulic adjuster.

Remember to keep headstay tight for best performance when furling or reefing.

If your boat is fitted with an adjuster be sure that it is tensioned **before** the halyard is tensioned. If not, backstay adjuster may increase halyard tension and could damage the sail or furling system.

Racing boats often slack the headstay completely when sailing downwind. Check to be sure that foil does not jam against upper headstay terminal when backstay is released. To prevent this, it may be necessary to shorten foil slightly.





Raise Sails

- 1) Install prefeeder by securely tying end of line to a deck fitting or to toggle below furler so it is 2' (610 mm) below feeder.
- 2) Shackle tack of sail to drum. Install shackle so screw pin head is on same side as sun cover.
- 3) Secure genoa sheets to clew of sail.
- 4) Attach genoa halyard to halyard swivel.
- 5) Pass luff tape through prefeeder and feeder into foil groove.
- 6) Attach head of sail or pendant at head of sail to halyard swivel.
- 7) Hoist sail.

Tip: *New sails are often stiff and may hang up on prefeeder during raising. Do not force sail when it hangs up—lower and remove twist. Sails "break in" with use and will become easier to raise.*

Storm Sails

Most people will use one multi-purpose genoa for all their sailing, but it is not good seamanship to go offshore without storm sails.

Heavy-air working jibs and storm sails may be used with your unit. These sails need to have luff tape added to allow them to be raised in headstay foils.

These sails will generally require pendants to ensure that halyard swivel is properly positioned at top of headstay. See Page 26.

Remember that heavy-air working jibs and storm jibs may be reefed and furled like any other sail.

Furl and Reef

To furl or reef, ease the jib sheets and pull furling line.

In very light air, it may be necessary to place some tension on jib sheet to insure a tight furl.

In a breeze, you must **completely** luff sail by **totally** slacking jib sheets before furling.

The furling line should pull readily. The amount of force required is related to amount of wind, but a Unit 3 should never require use of a winch to furl. If sail will not furl, or if furling requires a great deal of effort, there is a problem with system. Consult the Troubleshooting Guide on Page 33. Do not use a winch to force a system to turn. If you are certain that the system is operating properly, you may use a winch to make furling easier.



Reef

A sail may be partially furled before you resume sailing. This is known as reefing.

Many sailors find it helpful to place marks on foot of sail so that they can reef to a variety of predetermined jib sizes. This allows marks to be placed on jib lead tracks or toe rail so that lead block position can be changed to correspond to reefed jib.

Your system is provided with a “locking” device that can be used to lock unit while reefed or when leaving boat unattended at dock or mooring. To lock unit in reefed or furled configuration, align holes in bottom of drum and basket, then use a line to secure drum. Use of lock removes tension from furling line and prevents accidental release of line which could expose a full sized genoa to heavy winds.

Use of lock while reefed requires going onto foredeck after reefing and again before sail can be reefed further or unreefed. Since one purpose of a reefing system is to allow you to change sail size while remaining in safety of cockpit, many people choose not to use locking device. Use of locking device is not required during reefing.

Sails are generally reefed to balance boat and to reduce heeling moment. Sails may also be reefed to improve visibility or to slow boat while sailing in congested areas or entering or leaving harbors.



Secure Sail

When furling prior to leaving your boat in slip or on mooring, be sure that you get a tight furl and continue furling system until sheets wrap around rolled sail two or three times. Some people secure sail with shock cord or sail ties. Be sure to securely cleat furling line to a standard horn cleat.

You may also lock your system by aligning holes in bottom of drum and basket and then using a line to secure drum.

Be sure that mooring lines are not placed across furling line where they may cause chafe.



Race conversion allows use of both grooves for sail changes and tacking genoas on deck for use of maximum luff length genoas.

Halyard Swivel Below Feeder

Use halyard to lift halyard swivel up, away from feeder. Loosen screw **one revolution only**. Slide screw up and hold. Remove feeder carefully—bottom end first. **Don't lose the feeder overboard!** Lower swivel onto drum assembly. Replace feeder.

Halyard Swivel Off Furler

Serious racers may want to remove the halyard swivel.

Note: It is not possible to remove halyard swivel on a unit with a Norseman/Sta-Lok® or rod adapter stud unless you disassemble terminal stud. Make sure you use a new Norseman/Sta-Lok® wedge to reassemble Norseman/Sta-Lok® fitting.

- 1) Remove drum assembly.
- 2) Rig a secure, temporary headstay.
- 3) Loosen backstay, mainsheet and vang so that headstay goes slack.
- 4) Remove clevis pin holding furling unit to chainplate.
- 5) See adjusting turnbuckle on Page 24. Remove turnbuckle body and lower unit and slide off halyard swivel.
- 6) Reattach headstay to boat.

Remove Drum

- 1) Remove sail and unwind line from drum. Line can remain attached to drum.
- 2) Use 10mm Allen wrench provided to remove 2 screws on bottom of guard assembly and remove two halves. Be careful—screws are not captive.
- 3) Use a 3mm Allen wrench to loosen four screws in plastic cover and flange.

Remove Feeder



Loosen screw **one revolution only**.



Slide screw up and hold.

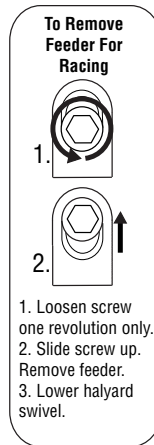

Carefully remove feeder—bottom end first. **Don't drop the feeder overboard!**





WARNING! Periodically inspect items listed below and any others as necessary. Failure to inspect can cause an accident, damage to your vessel, personal injury or death. See www.harken.com for additional safety information.



Inspection

Inspect unit for signs of chafe, wear or damage.
 Inspect clevis and cotter pins below and inside drum assembly for signs of loosening. Check headstay tension for signs of loosening.
 Inspect swage fitting and lower toggle for signs of stress corrosion.
 Inspect Norseman or Sta-Lok terminal or rod terminal for signs of loosening.
 Inspect all screws on unit to be sure they have not loosened.
 Inspect foil to make sure that it has not dropped into drum assembly. Periodically inspect wire for signs of wear or unraveling.

Replace Line

Use $\frac{7}{16}$ " (11mm) diameter line. Use double-braid polyester line with good wear characteristics.

Storage – Mast Down

In areas where it freezes, do not store system where water can accumulate in foils. When water freezes it will rupture aluminum. Store foils under cover, with grooves facing down or on an angle so water will run out.

Storage/Transporting

Do not store or transport system with drum assembly extending beyond mast. Remove masthead clevis pin and shift furler up so drum assembly can be strapped securely to mast. Some people remove drum assembly and halyard swivel for storage and transport.

After Storage or Transport

After storing or transporting unit, clean thoroughly including ball bearings. See instructions above.

Loosen Foil Clamp Before Slacking Backstay

In order to prevent foils from locking against upper stay terminal when backstay is released, loosen foil clamp screws and lower foil before loosening backstay.

Clean and Lubricate

Keep unit clean. When you wash boat, flush unit with soap and fresh water. Occasionally lower sail and flush halyard swivel with soap and fresh water.

At least twice a year unit should be cleaned more thoroughly by removing line (first note direction of spool) and flushing bearings with soap and fresh water. After unit has dried, apply a dry spray lubricant such as McLube®.

Foils may be cleaned by washing with soap and water. A scrap of luff tape may be run up foil to scrub inside grooves. Foils may be sprayed with McLube® spray to reduce friction during sail changes.



Troubleshoot

Problem	Probable Cause	Solution	
Sail will not furl or is difficult to furl.	Jib halyard is wrapping around headstay because angle between mast and halyard is too shallow	See installation instructions regarding optimal halyard angle. It may be necessary to mount a halyard restrainer on front of your mast to hold halyard to rear.	
	Jib halyard is wrapping around the headstay because halyard swivel is too low.	See installation instructions regarding optimal halyard swivel height. A wire pendant may be needed at head of sail to raise halyard swivel to proper height.	
	Jib halyard is too tight.	Ease jib halyard.	
	Foils riding on turnbuckle.	Raise foils. See adjusting turnbuckle on Page 24.	
	Foils too high, binding on swage eye.	Lower foils until clear. See adjusting turnbuckle on Page 24.	
	Spare halyard is wrapping in sail as it furls.	Secure spare halyards away from furling headstay by flipping them behind spreaders	
	Salt or dirt in bearings.	Flush bearings with freshwater and lubricate with dry spray lubricant such as McLube®	
	Furling line tangled in drum.	Overrides are best prevented by using a 7402 ratchet block as the last furling line lead to maintain proper drag on line while unfurling.	
	Stop knot catching.	Make sure knot is a single overhand and is pushed up inside drum.	
	Sail full of wind.	Luff completely before furling or reefing.	
	Sail flogging too much.	Release a short length of sheet, pull some furling line and repeat.	
	Jib sheets are not free.	Free jib sheets.	
	Foil out of drum assembly.	Reinstall foil in drum assembly and tighten clamp screws.	
	No wraps of furling line on drum.	Remove sheets. Rotate stay wrapping as much furling line on drum as possible.	
	Lineguard assembly has slipped down.	Tighten line guard assembly screws securely.	
Sail will not unfurl or will not unfurl completely.	Line through 7402 ratchet backwards.	Rerun line.	
	Halyard swivel installed upside down.	Remount swivel correctly.	
	Jib halyard is wrapping around headstay because angle between mast and halyard is too shallow.	See installation instructions regarding optimal halyard angle. It may be necessary to mount a halyard restrainer on front of your mast to hold halyard to rear.	
	Jib halyard is wrapping around the headstay because the halyard swivel is too low.	See installation instructions regarding optimal halyard angle.	
	Foils riding on turnbuckle.	Raise foils. See adjusting turnbuckle on Page 24.	
	Foils too high, binding on swage eye.	Lower foils. See adjusting turnbuckle on Page 24.	
	Jib halyard is too tight.	Ease jib halyard.	
	Spare halyard is wrapping in sail as it furls.	Secure spare halyards away from furling headstay by flipping them behind spreaders	
	Salt or dirt in bearings.	Flush bearings with freshwater and lubricate with dry spray lubricant such as McLube®	
	Furling line is not free.	Free furling line.	
	Sail will not furl completely.	Insufficient furling line on drum.	Remove sheets. Rotate stay, wrapping as much furling line on drum as possible.
		Too much line on drum.	Adjust amount of line on drum or change position of forward lead block to allow line to roll evenly on drum.
		Spare halyard catching in sail as it furls.	Move halyards away from furling headsail as above.
	Headstay rotates in jerks or elliptically.	Insufficient tension on headstay.	Tighten headstay and/or backstay to eliminate sag in headstay.
	Sail does not stay furled.	Sail not furled tightly on stay.	Maintain drag on sheets while furling.
Furling line not secure.		Secure furling line.	
Sail will not go up.	Luff tape will not go into groove.	Check luff tape for fraying. Check luff tape size.	
	Sail catching at prefeeder.	Flake sail more loosely on deck.	
	Dirt in groove.	Clean groove.	
	Sail will not raise completely or luff will not tension.	Halyard swivel is hitting end stop.	Luff of sail is too long and must be recut.
Angle between halyard and mast is too sharp and halyard is pulling too much to the rear.		Halyard must be routed from a point higher on mast. This may require that any halyard turning blocks aloft be replaced or sail shortened.	
Sail will not come down.	Halyard is wrapping on headstay.	Angle between headstay and halyard is too shallow and must be optimized per installation instructions.	
	Halyard swivel off foil.	Sail luff too long or foil is too short or low and must be lengthened or raised.	
Ultraviolet cover rolls up inside of sail.	Furling line is wrapped on drum in wrong direction.	Remove sheets. Pull line to remove all furling line from drum. Turn stay to rewind line on drum in opposite direction. Line guard and cowling alignment may need to be adjusted.	
Line jams between guard and plastic spool plate.	Line is not led through windows.	Pull line through enclosed window.	

Warranty — Online at www.harken.com or call, write, email or fax Harken, Inc., Pewaukee, WI USA

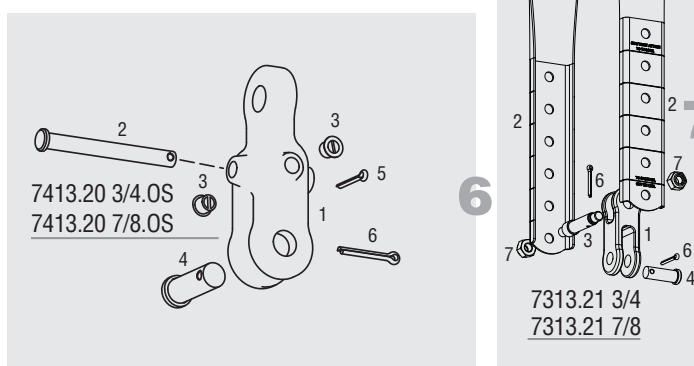
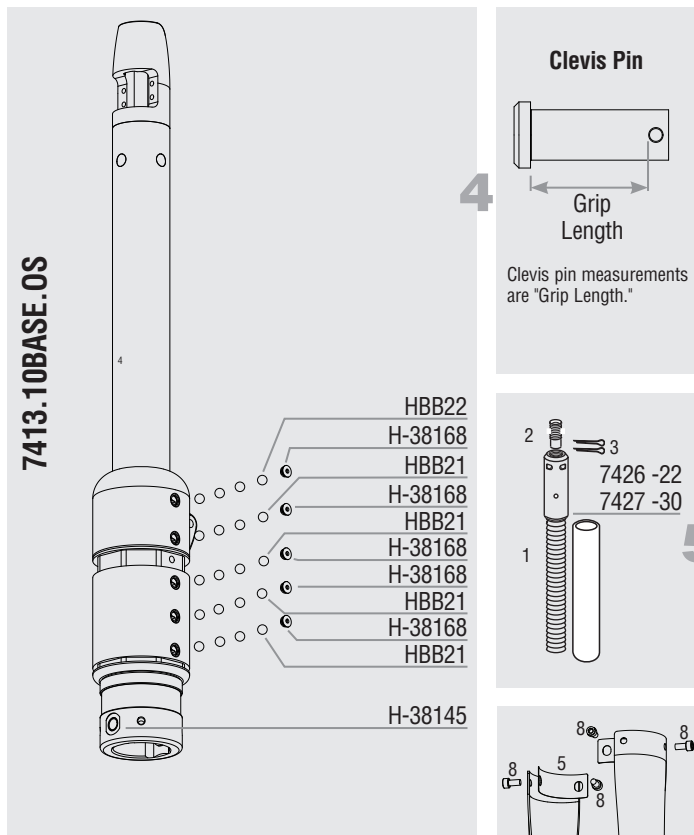
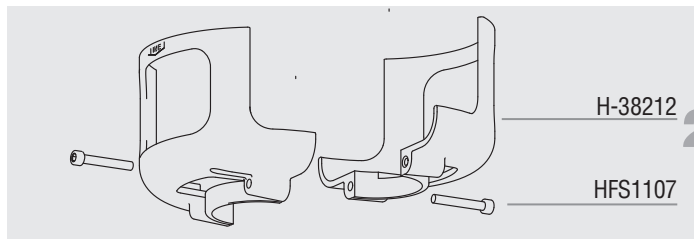
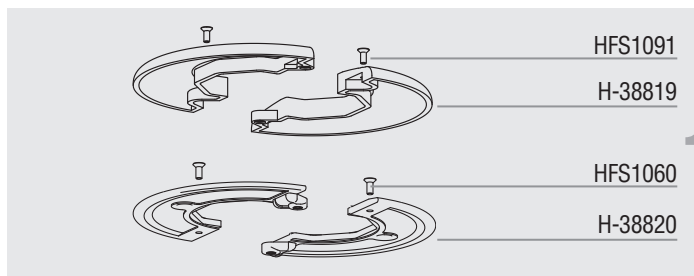

	Description	Order	Part No.
1	Top Cover	2	H-38819
	Top Cover Screw	2	HFS1091
	Bottom Flange	2	H-38820
	Bottom Flange Screw	2	HFS1060
2	Guard	2	H-38212
	Guard Screw	2	HFS1107
	Clamp	1	H-42967
	Clamp Screw	4	HFS1107
3	Hub Assembly	1	7413.10BASE.OS
	Ball Plugs	5	H-38168
	Torlon Ball Bearing (1/2")	25	HBB22
	Delrin Ball Bearing (1/2")	100	HBB21
	Igus Crosspin Bushing	4	H-38145

No.	Description	Order	Part No.
5	Rod Adapter Stud (-22) w/Nosepiece	1	7426 -22
	1 Stud (Main Body)	1	H-41812
	2 Nosepiece -22	1	H-41811
	3 Cotter Pin (3/32 x 1.750)	2	HFG319
6	Rod Adapter Stud (-30) w/Nosepiece	1	7427 -30
	1 Stud (Main Body)	1	H-41814
	2 Nosepiece -30	1	H-41813
	3 Cotter Pin (3/32 x 1.750)	2	HFG319
7	Eye/Jaw Toggle Reversible	1	7413.20 3/4.OS
	1 Toggle	1	H-42351
	2 Crosspin (1/2" x 4")	1	H-42402
	3 Cross Hole Plug	2	H-42052
8	Eye/Jaw Toggle Reversible	1	7413.20 7/8.OS
	1 Toggle	1	H-42352
	2 Crosspin (1/2" x 4")	1	H-42402
	3 Cross Hole Plug	2	H-42052

No.	Description	Order	Part No.
9	Long Link Plate w/Toggle		7313.21 3/4
	1 Toggle	1	H-41489
	2 Plates	2	H-42568
	3 Cross Pin (Custom)	1	H-42583
	4 Clevis Pin	1	H-42403
	5 Isolator	2	H-42585
10	Long Link Plate w/Toggle		7313.21 7/8
	1 Toggle	1	H-42562
	2 Plates	2	H-42568
	3 Cross Pin (Custom)	1	H-42584

No.	Description	Order	Part No.
11	Long Link Plate w/Toggle		7313.21 7/8
	1 Toggle	1	H-42562
	2 Plates	2	H-42568
	3 Cross Pin (Custom)	1	H-42584
	4 Clevis Pin	1	H-42404
	5 Isolator	2	H-42585
	6 Cotter Pin	2	HFS203
	7 Nylock Nut	2	HFS991
12	Long Link Plate w/Toggle		7313.21 7/8
	1 Toggle	1	H-42562
	2 Plates	2	H-42568
	3 Cross Pin (Custom)	1	H-42584

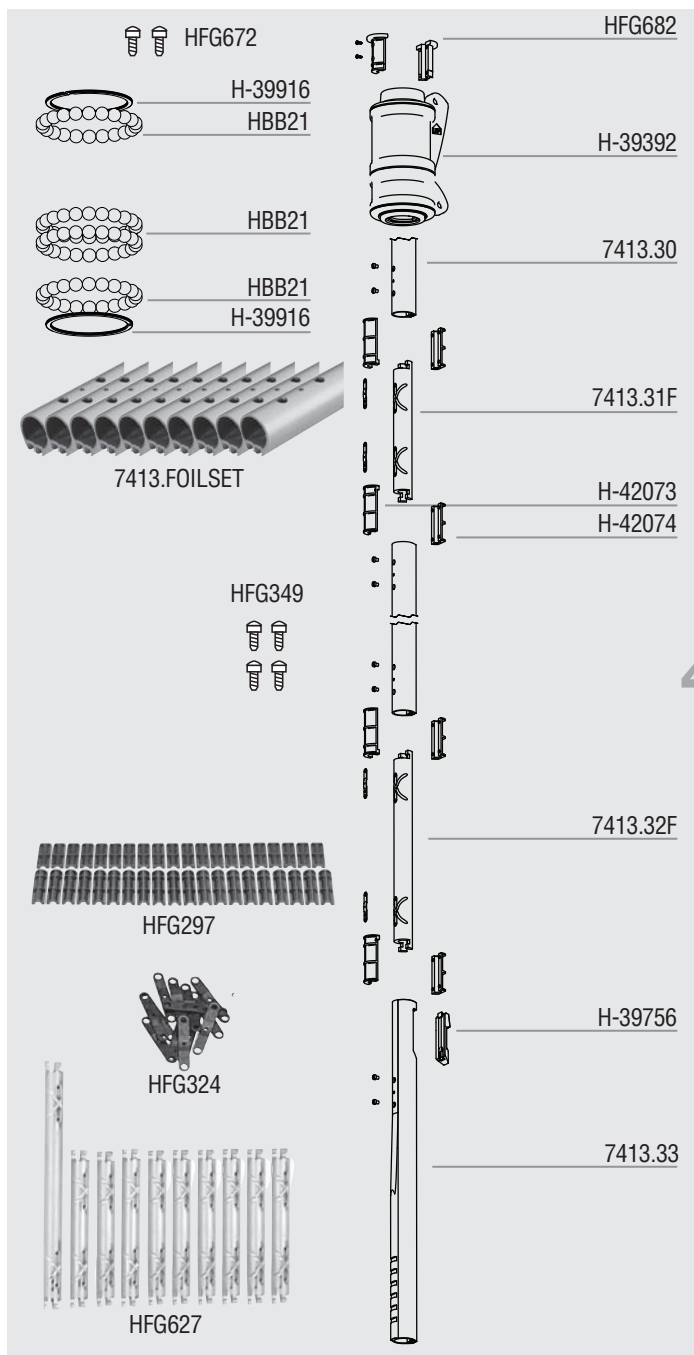

4

Description	Order	Part No.
Trim Cap Set w/o Screws	1	HFG682
Trim Cap Screw Set	1	HFG672
Trim Cap Screw	2	HFS1127
Halyard Swivel	1	H-39392
Clip/Smally Ring for Balls	2	H-39916
Torlon Ball Bearings	88	HBB21
Foil Set	1	7413.FOILSET
Foil (7' / 2.13 m Luff)	10	7413.30
Foil (2' / 610 mm) Bottom	1	7413.33
Foil Screw Set	1	HFG349
Foil Screw	46	HFS1106
Connector Set	1	HFG627
Connector	9	7413.31F
Bottom Connector (9 ³ / ₄ " / 247 mm)	1	7413.32F
Connector Bushing Set	1	HFG297
Connector Bushing Top (Curved/Longer)	20	H-42073
Connector Bushing Bottom (Flat/Shorter)	20	H-42074
Plastic Connector Wedge Set	1	HFG324
Plastic Connector Wedge	22	H-39487
Feeder with Screw and Tab	1	H-39756
Feeder Tab	1	H-38372A
Screw	1	HFS1130

4

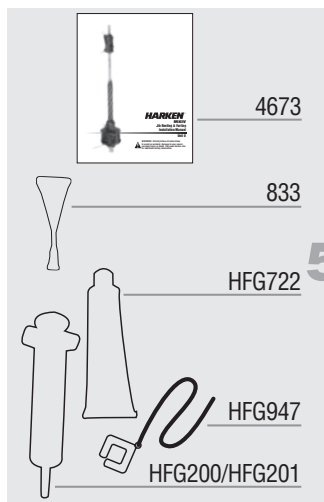

5

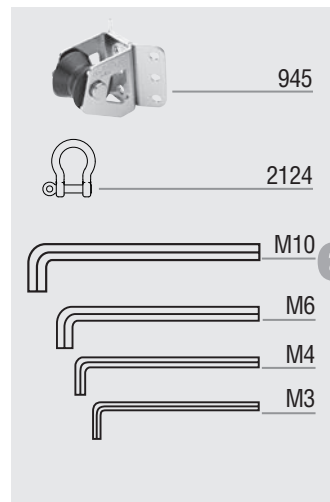

6

5

Description	Order	Part No.
Instruction Manual	1	4673
Blue Loctite®	1	833
5200 Adhesive Set	1	HFG725
5200 Marine Adhesive Sealant	1	HFG722
Injector	1	HFG200 HFG201
Prefeeder	1	947

6

Description	Order	Part No.
Halyard Restraint (Optional)	1	945
Sheave/SS Inner Race Only	1	945A
Clevis Pin (1/4" x 1.0625" 18-8)	1	HCP208
Bracket-Large	1	HCP394
Cotter Pin (1/16" x .500" 18-8)	1	HFS181
Shackle	3	2124
Allen Wrenches		
M10	1	HFG647
M6	1	HFG644
M4	1	HFG640
M3	1	HCP1089

HARKEN®

Corporate Headquarters

1251 East Wisconsin Avenue, Pewaukee, Wisconsin 53072 USA
Telephone: (262) 691-3320 • Fax: (262) 691-3008 • Cable: Harken Pewaukee
Web: www.harken.com • Online Catalog: www.harkenstore.com
Email: harken@harken.com

Harken France

ZA. Port des Minimes, BP 3064, 17032 - La Rochelle Cedex 1, France
Telephone: (33) 05.46.44.51.20 • Fax: (33) 05.46.44.25.70
Web: www.harken.fr
Email: harken@harken.fr

Harken Italy S.P.A.

Via Marco Biagi, 14, 22070 Limido Comasco, (CO), Italy
Telephone: (39) 031.3523511 • Fax: (39) 031.3520031
Web: www.harken.it
Email: info@harken.it

Harken UK Ltd.

Bearing House, Ampress Lane
Lymington, Hampshire SO41 8LW, England
Telephone: (44) 01590-689122 • Fax: (44) 01590-610274
Web: www.harken.co.uk
Email: enquiries@harken.co.uk

Harken Poland

ul. Lisa Kuli 4 Lok.1, 01-512 Warszawa, Polska
Telephone: +48 607 979 747
Web: www.harken.com
Email: polska@harken.com

Harken Sweden

Mjölkekilsgatan 6, Box 64
S-440 30 Marstrand, Sweden
Telephone: (46) 303-618 75 • Fax: (46) 303-618 76
Web: www.harken.se
Email: harken@harken.se

Harken Adriatik d.o.o.

Obala 107
6320 Portoroz, Slovenia
Telephone/Fax: 5-6774122
Web: www.harken.si
Email: info@harken.si

Harken Australia, Pty, Ltd.

1B Green Street
Brookvale, N.S.W. 2100, Australia
Telephone: (61) 2-8978-8666 • Fax: (61) 2-8978-8667
Web: www.harken.com.au
Email: info.harken.com.au

Harken New Zealand, Ltd.

30-36 Fanshawe Street
Auckland 1001, New Zealand
Telephone: (64) 9-303-3744 • Fax: (64) 9-307-7987
Web: www.harken.co.nz
Email: harken@harken.co.nz

Please visit: <http://www.harken.com/dealers/dealers.php>
for an up-to-date list of Harken dealers and distributors



Printed in USA 4419-02/02/10