

Installation and Maintenance Manual

MRPW-03

Powered Performa™ Winch **70.2 STP E/HY**



HARKEN®

Introduction	3
Technical characteristics	3
<i>Performance data</i>	3
<i>Weight</i>	4
<i>Maximum working load</i>	4
Outline	4
<i>Winch 70.2 STP E</i>	4
<i>Horizontal electric motor</i>	4
<i>Vertical electric motor</i>	5
<i>Hydraulic motor</i>	5
Installation	6
<i>Installation procedure</i>	7
<i>Winch installation procedure</i>	8
<i>Positioning the self-tailing arm</i>	9
<i>Motor installation procedure</i>	9
<i>Electric wiring diagrams</i>	10
<i>Hydraulic connections diagram</i>	12
Maintenance	13
<i>Washing</i>	13
<i>Maintenance table</i>	13
<i>Winch disassembly procedure</i>	13
<i>Winch exploded view with maintenance products</i>	17
<i>Winch assembly</i>	18
Harken® limited worldwide warranty	19
Ordering spare parts	19
Exploded view	20
<i>Performa Winch 70.2 STP E/HY</i>	20
<i>Horizontal electric motor</i>	23
<i>Vertical electric motor</i>	24
<i>Hydraulic motor</i>	25
Parts list	22
<i>Performa Winch 70.2 STP E/HY</i>	22
<i>Horizontal electric motor</i>	23
<i>Vertical electric motor</i>	24
<i>Hydraulic motor</i>	25

Introduction

This manual gives technical information on winch installation and maintenance, including disassembling and reassembling.

This information is DESTINED EXCLUSIVELY for specialised personnel or expert users.

Installation, disassembling and reassembling of the winch by personnel who are not experts may cause serious damage to users and those in the vicinity of the winch.

Harken® accepts no responsibility for defective installation or reassembly of its winches.

In case of doubt the Harken® Tech Service is at your disposal at techservice@harken.it

This Manual is available only in English. If you do not fully understand the English language, do not carry out the operations described in this Manual.

Technical characteristics

	Power ratio	Gear ratio
1st speed	22,20 : 1	5,71 : 1
2nd speed	72 : 1	18,46 : 1

The theoretical power ratio does not take friction into account.

Performance data

Winch 70.2 STP E
(electric)

	horizontal motor				vertical motor			
	12 V (1500 W)		24 V (2000 W)		12 V (1500 W)		24 V (2000 W)	
	1st speed	2nd speed	1st speed	2nd speed	1st speed	2nd speed	1st speed	2nd speed
line speed (m/min)**	16,1	5,0	19,4	6,0	18,5	5,7	22,2	6,9
max load (Kg)	870	2700	870	2700	870	2700	870	2700

**Line speed is measured with no load

winch 70.2 STP E		motor nominal power (W)		current absorption at winch MWL (A)	
		12 V	24 V	12 V	24 V
		horizontal	vertical	horizontal	vertical
	horizontal	1500	2000	280	150
	vertical	1500	2000	250	140

Winch 70.2 STP HY
(hydraulic)

	1st speed	2nd speed
line speed (m/min)*	27,6	8,5
max load (Kg)***	870	2700

* at 30 L/min oil flow (5,28 Gall/min)

*** at 110 bar a 30 L/min

NOTE

The ratio the line load - pressure are evaluated at flow 20 l/min,

at different flow the line load - pressure ratio change and it's minimum at motor stall.

The pressure on the graph it's the pressure drop between in and out motor ports.

The performance are evaluated measuring the pressure and flow on the motor ports.

Performance data based on oli with a viscosity of 35mm²/s [165 SUS] and temperature of 50° [120° F]

Weight

	ST EH	ST EV	ST H
weight (Kg)	22,1	22,8	18,8

Versions:

EH = horizontal electric winch

EV = vertical electric winch

H = vertical hydraulic winch

Maximum working load



WARNING!

The maximum working load (MWL) for the 70.2 ST E/HY Performa™ Winch is 2700 Kg (5952 lb). Subjecting the winch to loads above the maximum working load can cause the winch to fail or pull off the deck suddenly and unexpectedly during high loads causing severe injury or death.

Outline

Winch 70.2 STP E/HY

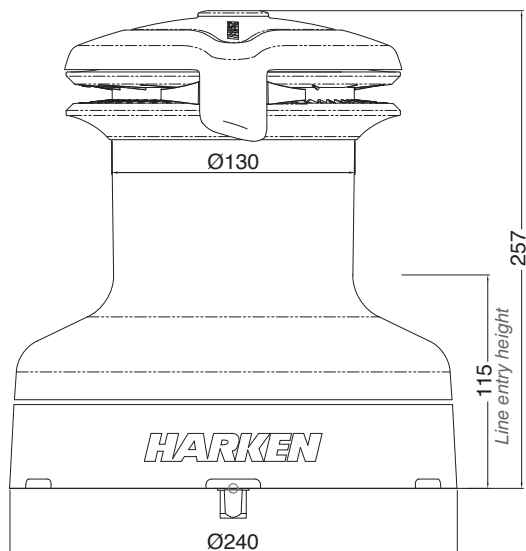

Horizontal electric motor (12 V / 24 V)

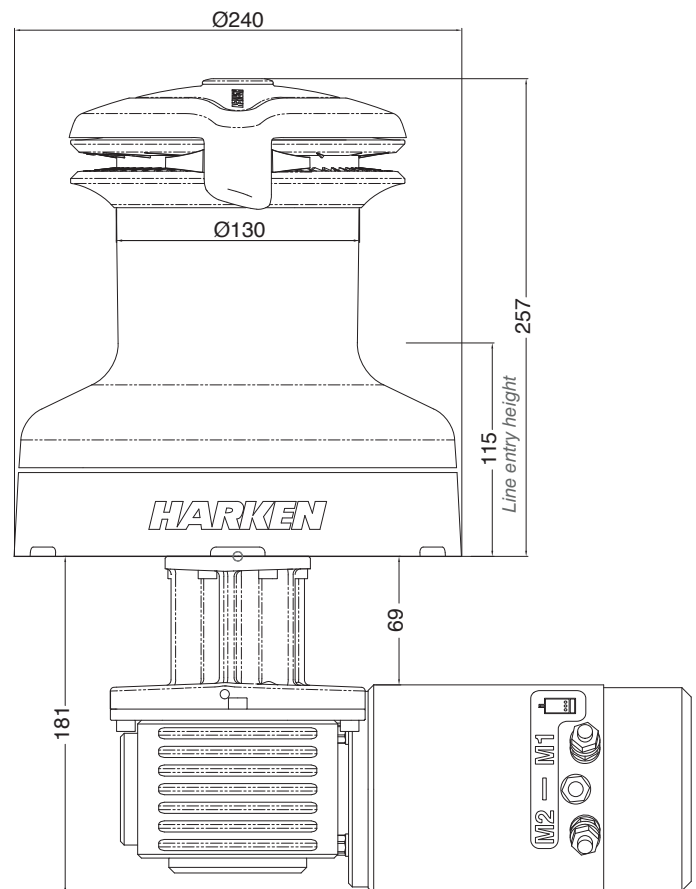

Vertical electric motor (12 V / 24 V)

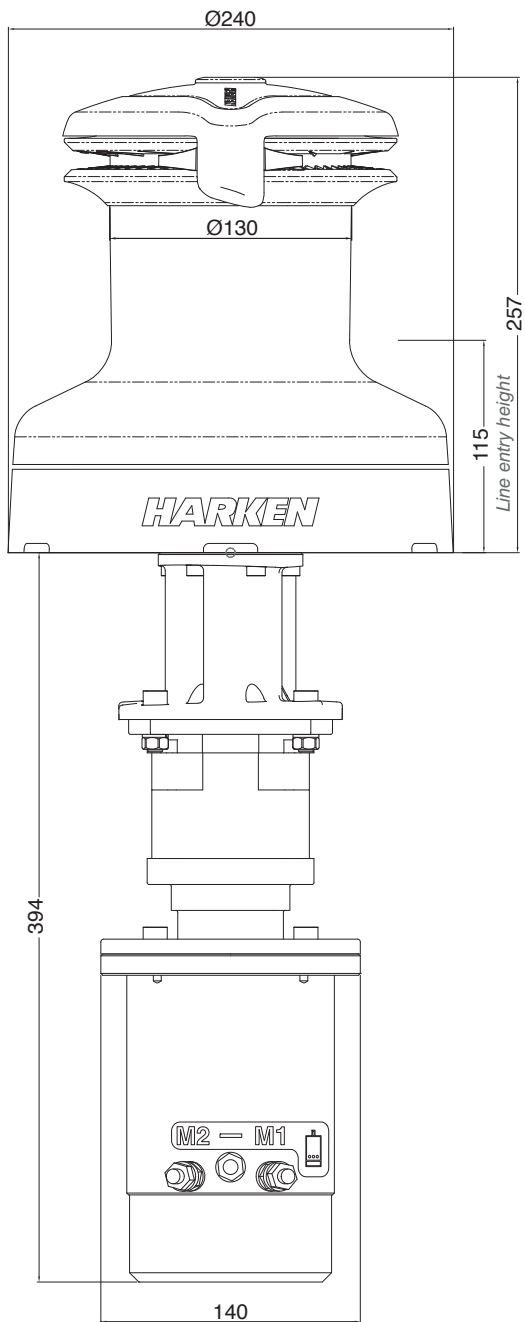

Hydraulic motor

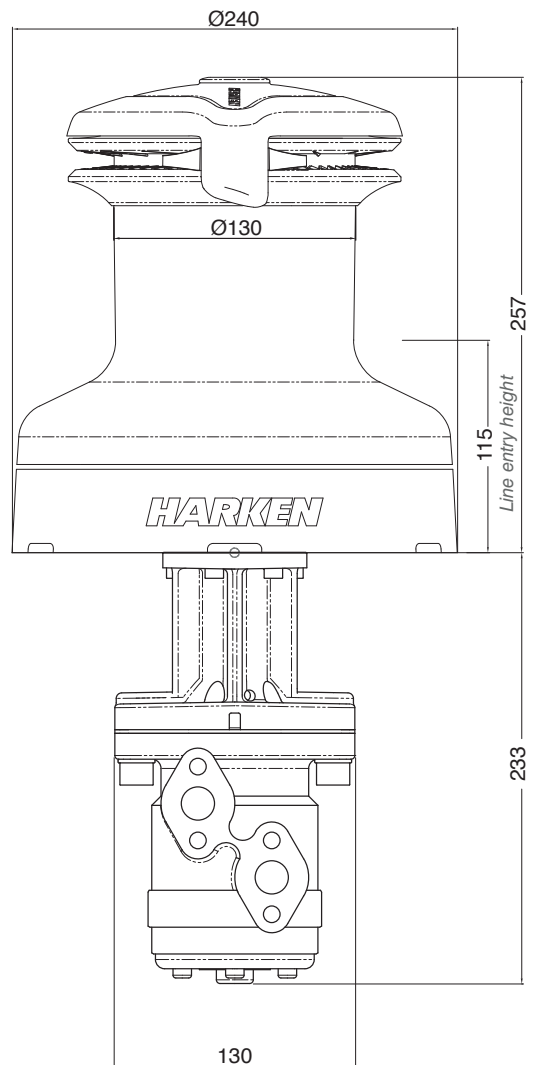

Installation

The winch must be installed on a flat area of the deck, reinforced if necessary to bear a load equal to at least twice the maximum working load of the winch.

It is the installer's responsibility to carry out all structural tests needed to ensure that the deck can bear the load.

Harken® does not supply the screws needed to install the winch since these may vary depending on the deck on which it is to be installed.

It is the installer's responsibility to choose the correct screws taking account of the loads they will have to bear.

Harken® assumes no responsibility for incorrect installation of its winches or for an incorrect choice of mounting screws.

DANGER!

Incorrect installation of the winch may cause severe injury or death. Consult the yard that built the boat in the case of doubt over the correct positioning of the winch.



WARNING!

Failure to use the correct number and type of mounting fasteners or failure to ensure the correct deck strength can result in the winch pulling off the deck suddenly and unexpectedly during high loads causing severe injury or death.



WARNING!

Verify the entry angle of the sheet. This must be 8° with tolerance of $\pm 2^\circ$, to avoid sheet overrides and damaging the winch or making the winch inoperable leading to loss of control of the boat which can lead to severe injury or death.

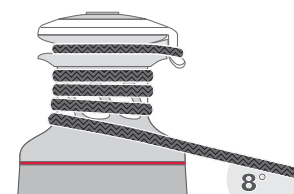

WARNING!

Mount the winch on the deck so that the drive gear is positioned where the sheet enters the winch drum. Incorrect position of drive gear can weaken winch leading to failure which can cause an accident leading to severe injury or death.

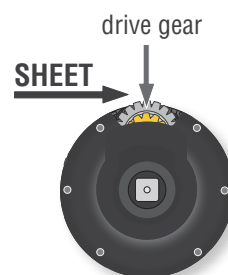

After correctly positioning the final pinion with respect to the load, check that the motor, gearing, electrical wiring and/or hydraulic pipes can be housed below decks. To help find the optimal compromise, remember that, to make the installation of the motor easier, it can be coupled to the winch in different positions.

Once you have decided the correct mounting position for the winch on the deck and checked the space available below deck, proceed with the installation.

Procedure

To install the winch you must remove the drum and use Socket Head (SH) bolts.

Tools needed

 One medium flat-bladed screwdriver

To identify the various parts, refer to the exploded view at the end of this Manual.

 Torque to apply when assembling



1. Pull out the disconnect rod n°30



2. Unscrew the central screw
( 2Nm/18 in-lb)



3. Slide off the assy socket n°29 and the cover n°28. Pay attention to the o-ring in the socket.



4. Unscrew the three screws n°27
( 4Nm/35 in-lb)



5. Remove the stripper arm n°26 by rotating and lifting it.



6. Lift off the drum n°23

Install the winch on the deck in the position you have chosen, keeping in mind the limits described on page 4 and using socket head (SH) bolts. (See paragraph on installation)

Winch installation procedure

Carry out the **Procedure**, then install the winch on the deck in the chosen position.

NOTICE

Before drilling the deck, check the space available below deck for the flange and the motor

- A.** Position the base of the winch on the deck and mark the position of the holes or use the drilling cut-out template at the point where you have decided to place the winch.

Below is a reduced scale diagram.

The drilling cut out template is available on the Harken® website, www.harken.com

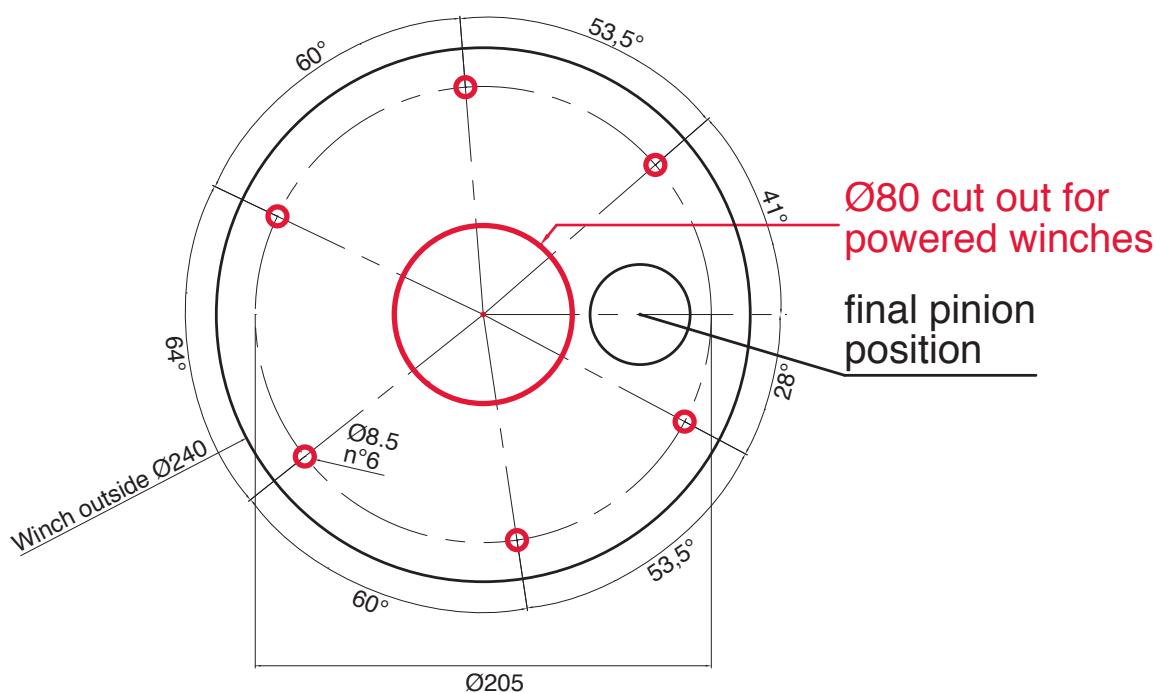

- B.** Remove the winch and drill the five 8.5 mm diameter holes.
- C.** Bolt the base of the winch to the deck using five M8 Socket Head (SH) bolts (no supplied by Harken®), correctly chosen for the thickness and type of the boat deck. Consult the yard that built the boat in case of doubt.



WARNING!

To install the winch on the deck, use only bolts in A4 stainless steel (DIN 267 part11). Bolts made of other materials may not have sufficient strength or may corrode which can result in winch pulling off deck suddenly and unexpectedly during high loads causing severe injury or death.

NOTICE

To mount winches on the deck, do not use countersunk bolts.

- D.** Fill the mounting holes with a suitable marine sealant.
- E.** Remove the excess adhesive/sealant from the holes and base drainage channels
- F.** Reassemble the winch following the steps of the **Procedure** in the reverse order, and apply the products indicated in the section on maintenance.

NOTICE

Before closing the winch, make sure the holes and drainage channels in the base of the winch are not obstructed.

Positioning the self-tailing arm

Position the self-tailing arm so that the line leaving the winch is led into the cockpit.

Motor installation procedure







WARNING!

Make sure that the power is switched off before installing or carrying out maintenance on the winch.

Once you have installed the winch on the deck, proceed with motor installation. The motor can be coupled to the winch in different positions. Check the space available below deck and choose the suitable position.

Tools needed

-  A number five hex key
-  A number six hex key (only for vertical electric motor)
-  A number ten hex key (only for hydraulic motor)
-  Two number thirteen wrenches



1. Position the flange (see Page 10)



2. Tighten six M6 precote coated screws (8 Nm/ 71 in-lb)



3. Position the reduction gear and motor



4. Tighten the two screws (8 Nm/ 71in-lb). Be sure to align the flange.

NOTICE

Before positioning the flange, check to make sure that seal is seated correctly.



After winch is assembled and before sailing, test the powered winch functioning: insert the lock-in winch handle in the handle socket and check that the disconnect rod must disconnect gearbox.

Electric wiring diagrams

To guarantee greater efficiency in terms of safety and long life, for every winch model is mandatory to install the Dual Function Control Box.

For more information, refer to the Dual Function Control Box manual.

Refer to the following diagrams for the electric wiring:

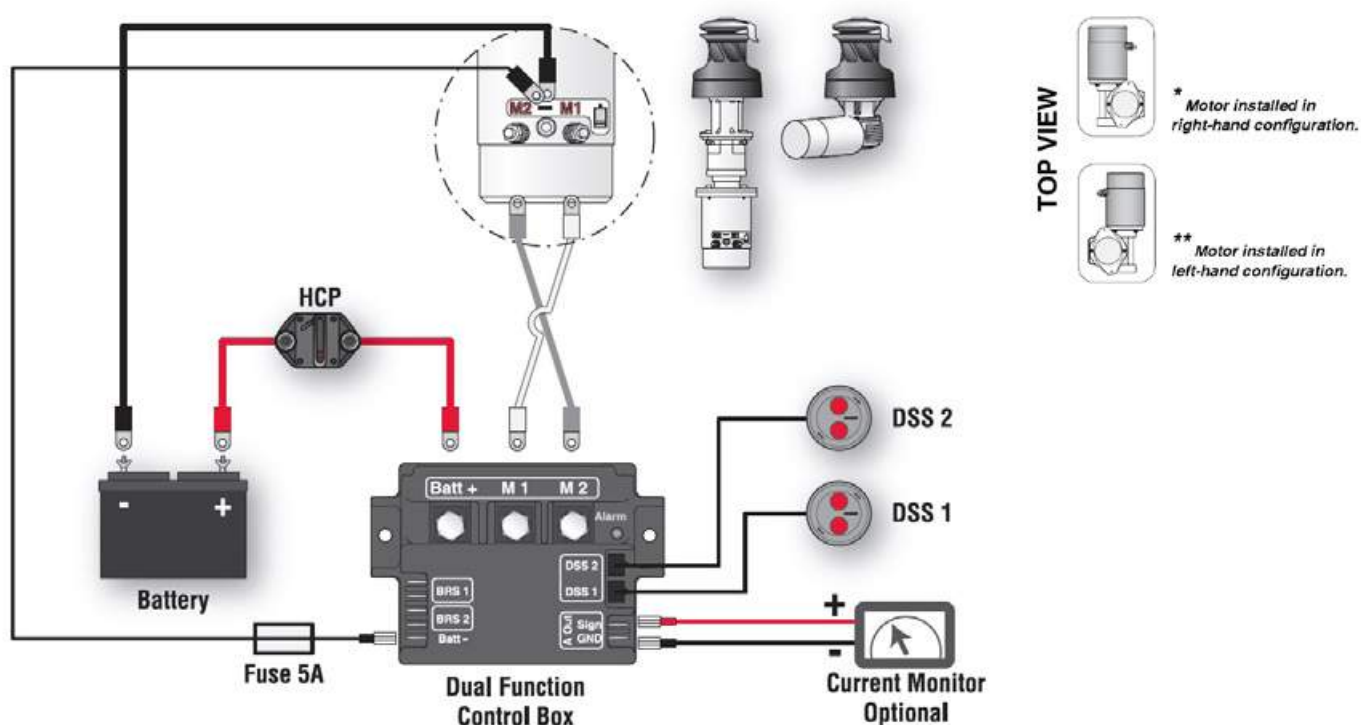

WARNING!

Read the Dual Function Control Box manual carefully before installing and using the device.

NOTICE

For other installations, refer to the Dual Function Control Box manual.

Fasten the Dual Function Control Box containing solenoids to bulkhead or wall: refer to the Dual Function Control Box manual. Install remote circuit breaker between power supply and Dual Function Control Box. Locate push-buttons on deck in a convenient spot for easy winch operation: refer to the Digital System Switch manual.

Refer to the following chart for wire size:

Total distance between winch and battery

Winch size	Current voltage	Under 16.4 ft AWG	Under 5 m mm ²	16.4-32.8 ft AWG	5 m-10 m mm ²	32.8-49.2 ft AWG	10 m-15 m mm ²	49.2-65.6 ft AGW	15 m-20 m mm ²
46.2	12 V	2	32	0	50	00	70	000	95
46.2	24 V	5	16	3	25	2	35	0	50

NOTICE

To connect motor, attach cable terminals to clamps between nut and lock nut. Hold nut in contact with motor using a spanner and tighten other nut with second spanner. Take special care not to turn the central spindles. Be careful not to turn central spindles. These instructions apply when assembling and disassembling. We recommend using a torque wrench so as to obtain a torque equal to and no greater than 10 Nm (88 in-lb).



NOTICE

Note that correct electrical contact sequence is:
Nut – Cable Terminal – Self-Locking Washer – Lock Nut



Hydraulic connections diagram

The hydraulic motor must be connected to a hydraulic system using two high-pressure tubes which serve for input or output according to the direction in which the motor will be run. The motor also needs a third connection with a low pressure tube for drainage, so that excess oil can return to the main tank to avoid shortening the life of the motor. This motor uses an open centre valve.

Refer to the following chart for the hydraulic system:

For the hydraulic motor:

Input/output pipe thread: G 1/2 – depth 15 mm

Drainage pipe thread: G 1/4 – depth 12 mm

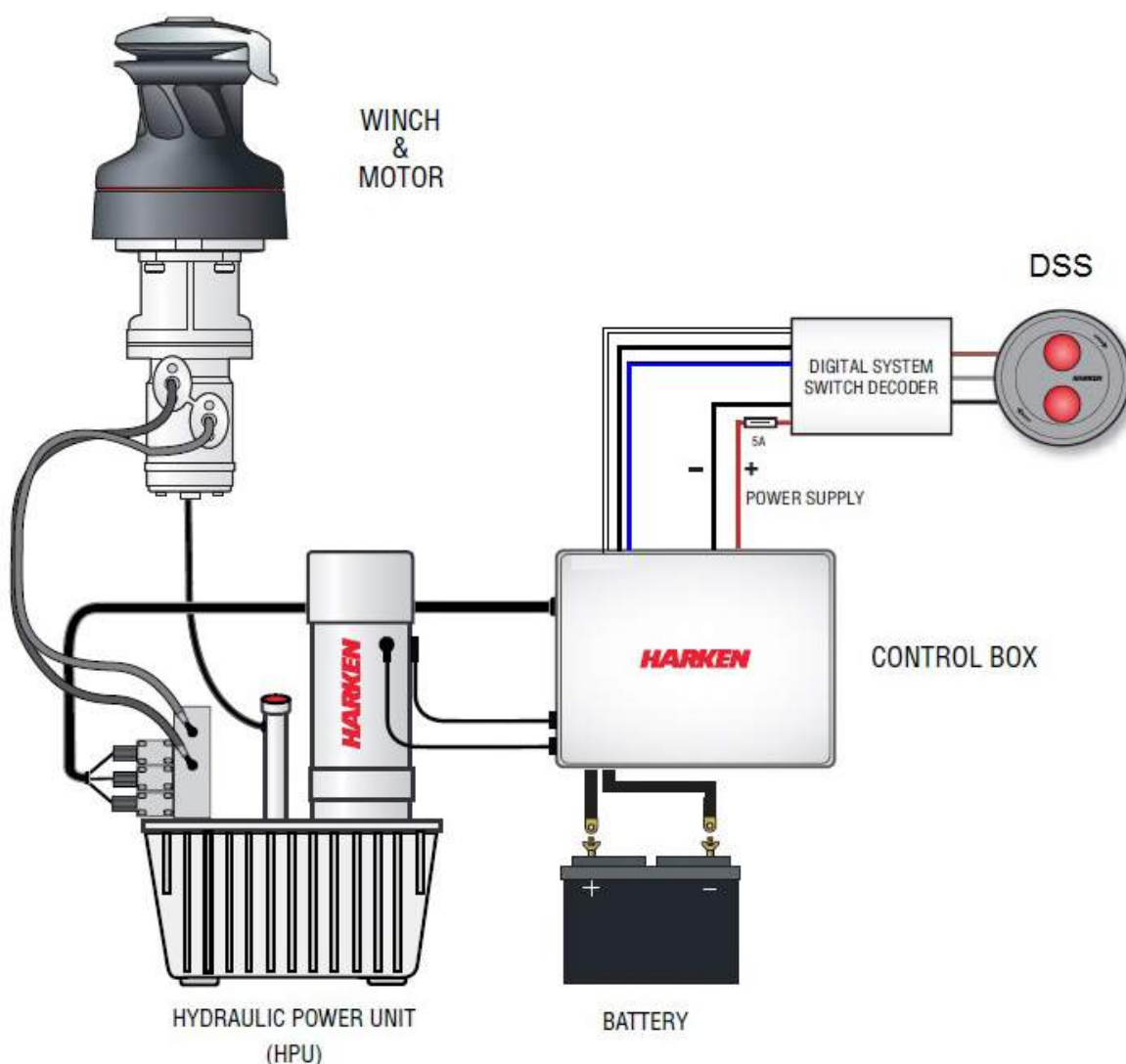

WARNING!

Refer to the Hydraulic Power Unit and Control Box manual.



WARNING!

Refer to the Digital System Switch manual.

Maintenance

Washing

Winches must be washed frequently with fresh water, and in any case after each use.

Do not allow teak cleaning products or other cleaners containing caustic solutions to come into contact with winches and especially anodised, chrome plated or plastic parts.

Do not use solvents, polishes or abrasive pastes on the logos, on the stickers on the winches or on any anodized, chrome plated and plastic surfaces.

Make sure that the holes and drainage channels in the base of the winch are not obstructed so that water does not collect.

Maintenance table

Winches must be visually inspected at the beginning and end of every season of sailing or racing. In addition they must be completely overhauled, cleaned and lubricated at least every 12 months. After an inspection, replace worn or damaged components. Do not replace or modify any part of the winch with a part that is not original.

**WARNING!**

Periodic maintenance must be carried out regularly. Lack of adequate maintenance shortens the life of the winch, can cause serious injury and also invalidate the winch warranty. Installation and maintenance of winches must be carried out exclusively by specialized personnel.

In the case of doubt contact Harken® Tech Service at techservice@harken.it

**WARNING!**

Make sure that the power is switched off before installing or carrying out maintenance on the winch.

Winch disassembly procedure

Tools needed



One medium flat-bladed screwdriver



A number five hex key



Brush

Rags

To identify the various parts refer to the exploded view at the end of this Manual.

 Torque to be applied in assembly phase

Carry out procedure as shown in the paragraph on winch installation and then do the following:



7. Completely unscrew the three screws n°27



8. Remove the stripper arm support n°21



9. Slide out the central shaft n°19



10. Unscrew the 6 hex screws n°17
( 20Nm/177 in-lb)



11. Remove the assy housing n°16



12. Remove the gear n°6, pawls n°4
and the washer n°7



13. Remove the gear n°2.



14. Remove the idler and pinion n°14.



15. Remove roller bearings n°15



16. Remove the pawls n°11.



17. Remove the gear n°10



18. Remove roller bearings n°12.

If it is necessary to replace any **jaws** of the winch, proceed as follows:



I. Unscrew the 4 screws n°25
($\approx 4\text{Nm}/35\text{ in-lb}$)



II. Remove the jaws n°22

Inspect balls inside the drum and carefully check the correct position; if it is necessary to put back any balls, push balls in the race (as shown below):



Once the winch is completely disassembled, clean the parts: use a basin of diesel oil to soak metal components and rinse plastic parts in fresh water. Once you have done this, dry the parts with cloths that do not leave residue.

Inspect gears, bearings, pins and pawls for any signs of wear or corrosion.

Carefully check the teeth of gears and ring gears to make sure there are no traces of wear.

Check the roller bearings and check there are no breaks in the bearing cages.
Replace worn or damaged components.

Carry out maintenance on components using the products listed below.

For more information on which products to use where, refer to the exploded diagram below.

Use a brush to lightly lubricate all gears, gear pins, teeth and all moving parts with grease.
Lightly lubricate the pawls and springs with oil. Do not use grease on the pawls!

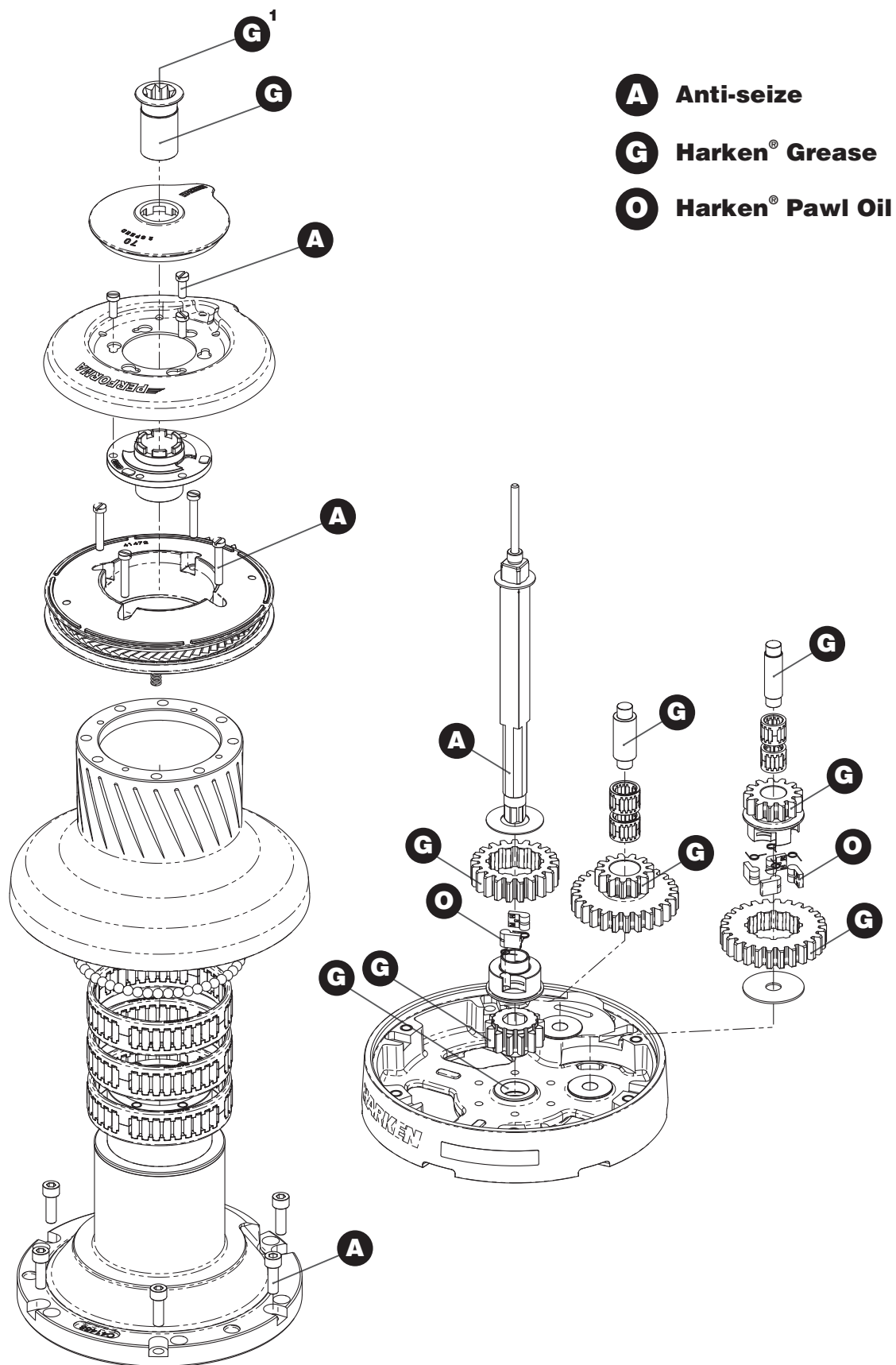
Winch exploded view with maintenance products

¹Apply Harken® grease on assy socket screw

Winch assembly

Make sure that the holes and drainage channels in the base of the winch are not obstructed
 Assemble the winch in the reverse order of the sequence in the section on disassembly.

To tighten bolts, use the torque indicated in the disassembly procedure.



When positioning the stripper arm, align the peeler with it. If the jaws have been disassembled, insert peeler between the two jaws, taking care that the letters TOP on the peeler are facing upwards.



The icon ▲ on the Stripper Arm Housing indicates the Stripper Arm final position. Change the Stripper Arm Housing angle to modify the Stripper Arm final position.

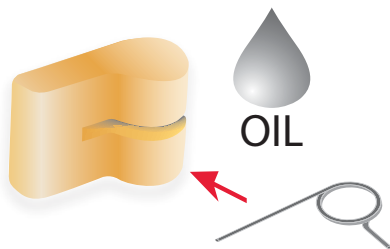

To assemble the pawls:

correctly position the spring in its housing as shown at left. Hold the spring closed and slide the pawl into its housing. Once in position, check that the pawls can be easily opened and closed with a finger.

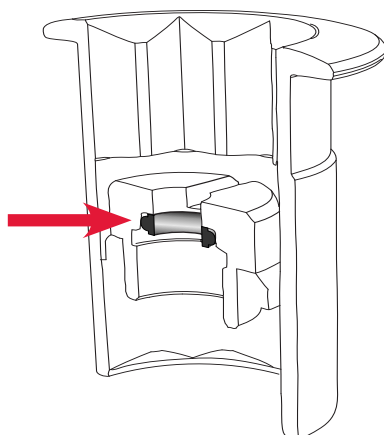

NOTICE

Before screw the central screw, check the correct position of the o-ring in the assy socket and apply Harken® grease.

In case of doubt concerning the assembly procedure contact Harken® Tech Service: techservice@harken.it

Harken® limited worldwide warranty

Refer to the Harken® Limited Worldwide Warranty in the Harken® Catalogue and on the website www.harken.com

Ordering spare parts

Spare parts can be requested from Harken® as described in the Harken® Limited Worldwide Warranty, indicating the part number in the Parts List and including the serial number of the winch for which the parts are required.

The serial number of the winch is printed on a plate on the drum support of the winch.



Manufacturer

Harken® Italy S.p.A.

Via Marco Biagi, 14
22070 Limido Comasco (CO) Italy
Tel: (+39) 031.3523511
Fax: (+39) 031.3520031
Email: info@harken.it
Web: www.harken.com

- **Tech Service**
Email: techservice@harken.it
- **Customer Service**
Tel: (+39) 031.3523511
Email: info@harken.it

Headquarters

Harken®, Inc.

1251 East Wisconsin Avenue
Pewaukee, Wisconsin 53072-3755 USA
Tel: (262) 691.3320
Fax: (262) 691.3008
Email: harken@harken.com
Web: www.harken.com

- **Tech Service**
Email: technicalservice@harken.com
- **Customer Service**
Tel: (262) 691-3320
Email: customerservice@harken.com

Exploded view 1/2



Performa Winch 70.2 STP E/HY

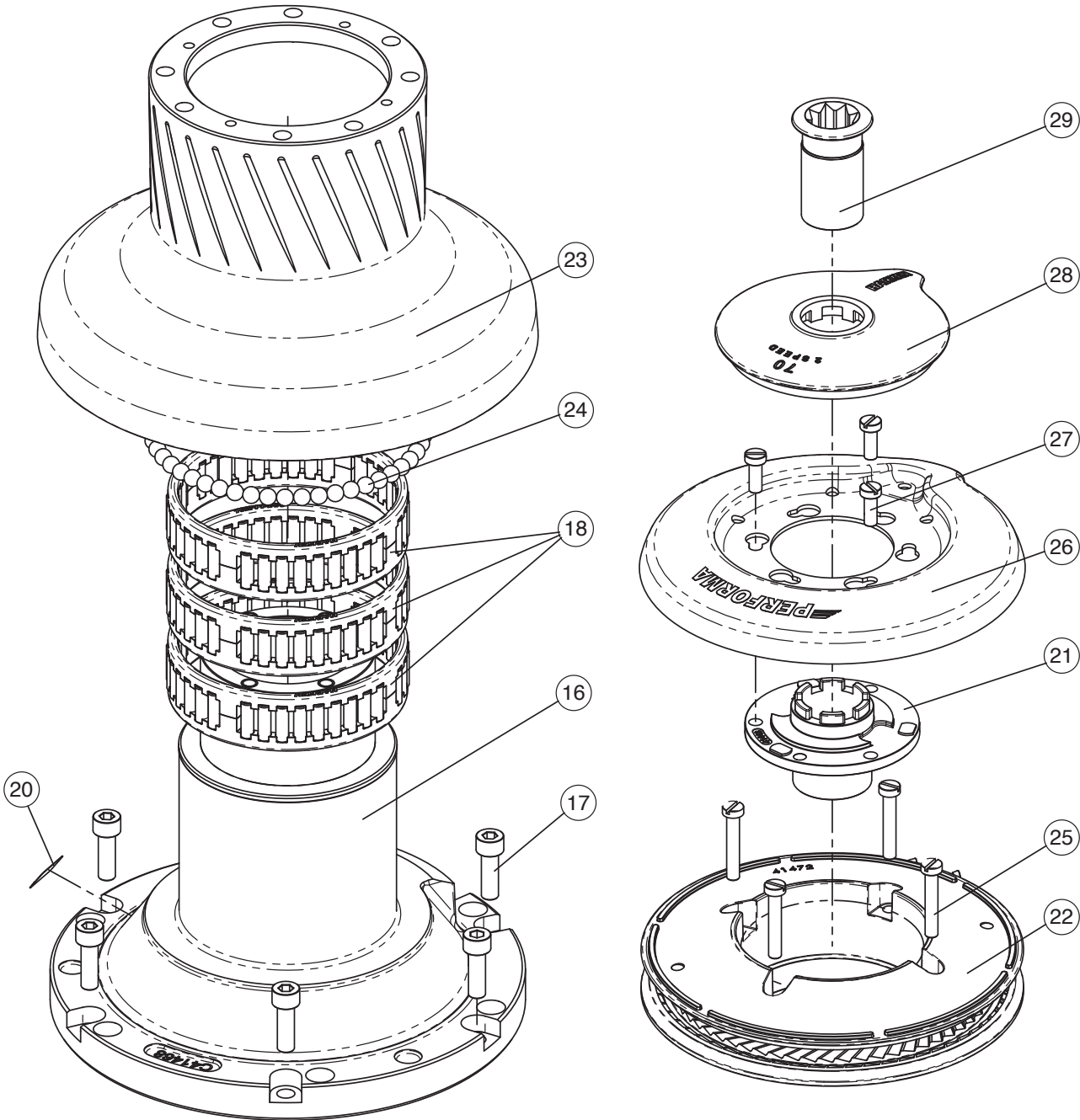

Performa Winch 70.2 STP E/HY

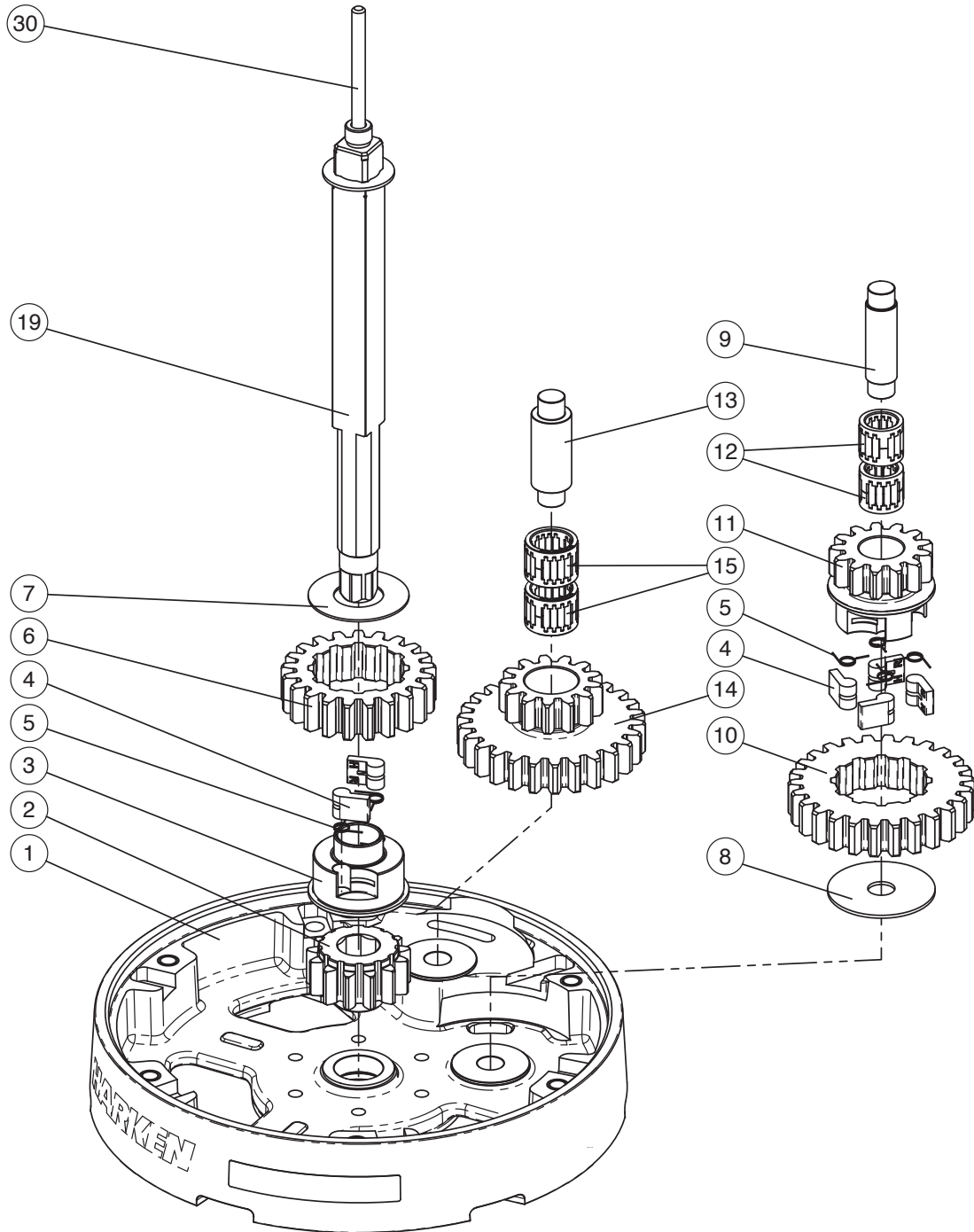

Performa Winch 70.2 STP E/HY

Pos	Q.ty	Code	Description	Pos	Q.ty	Code	Description	
1	1	A96645100	PERFORMA BASE ASSEMBLY W70 EL/HY <i>PERFORMA BASE W70 Heli-coil M8x10</i>	17	6	M0606303	Screw M8x25 UNI 5931	
	1	S476030004	<i>Centering bushing Ø12</i>	18	3	A74147500	Roller Bearing Ø102xØ114x26	
	1	S4130900A7	<i>Bushing Ø22xØ25x8.5</i>	19	1	A96753500	Assy Shaft Winch 70 EL/HY <i>Central Shaft Pred. W70</i>	
	2	S415580085	<i>Bushing Ø12xØ35x9 Winch Product Sticker**</i>		1	S413880002	<i>Washer Ø17.2xØ32x1.5</i>	
2	1	S414770004	Gear Z13 W70	20			Winch Serial Number Sticker	
3	1	S413030004	Pawls Carrier Ø8xN2	21	1	S4144300A0	Stripper Arm Housing W60/70	
4	6	S000090004	Pawl Ø8*	22	1	A96637200	PERFORMA Assy Jaws W70 <i>Lower Jaw W70</i>	
5	6	S000380001	Pawl Spring Ø8*		1	S414850080	<i>Upper Jaw W70</i>	
6	1	S414390041	Ratchet Gear Z21xN2		4	S018520001	<i>Peeler W60 - 70</i>	
7	1	S413120002	Washer Ø22.5xØ45x1				<i>Spring</i>	
8	1	S278170002	Washer Ø12.5xØ48x1.5	23	1	A76637000	PERFORMA Assy Drum Winch 70	
9	1	S281010004	Pin for gear	24	50	M0610280	Ball 5/16"	
10	1	S414420041	Ratchet Gear Z26xN4	25	4	M0601803	Screw UNI EN ISO 1207:1996 - M6x35 - A4	
11	1	S414410004	Pawls Carrier Gear Z13 N4	26	1	S663710019	PERFORMA Black Stripper Arm W70	
12	2	A72821800	Roller Bearing Ø14xØ20x18	27	3	M0601903	Screw M6x16 UNI1207	
13	1	S416030004	Gear Pin Ø12xØ18x52,5	28	1	S4160400B1	Cover 2 Speed W70	
14	1	S414760004	Idler and Pinion Z26/Z13 W70	29	1	A94149300	Assy Socket W35-80 EL/HY <i>Socket Handle W20/80</i>	
15	2	A74162300	Roll bearing Ø24xØ18x18		1	S414940085	<i>Washer Ø25xØ15x4</i>	
	16	1	A94146800	Assy Housing Winch 70 <i>Housing W70 Heli-coil M6x9</i>		1	S414930003	<i>Nut Screw for Disconnect Rod</i>
		2	S415580085	<i>Bushing Ø12xØ35x9</i>		1	M0679797	<i>O ring RC 2025 series</i>
		1	S4130900A7	<i>Support Bushing W70 Bushing Ø22xØ25x8.5</i>	30	1	S415090002	Disconnect Rod W70

*Available with service kit; see website www.harken.com

**Winch product sticker



Horizontal electric motor

TOP VIEW

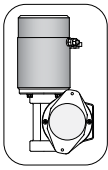

* **Motor installed in right-hand configuration.**

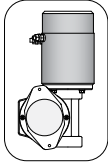

** **Motor installed in left-hand configuration.**

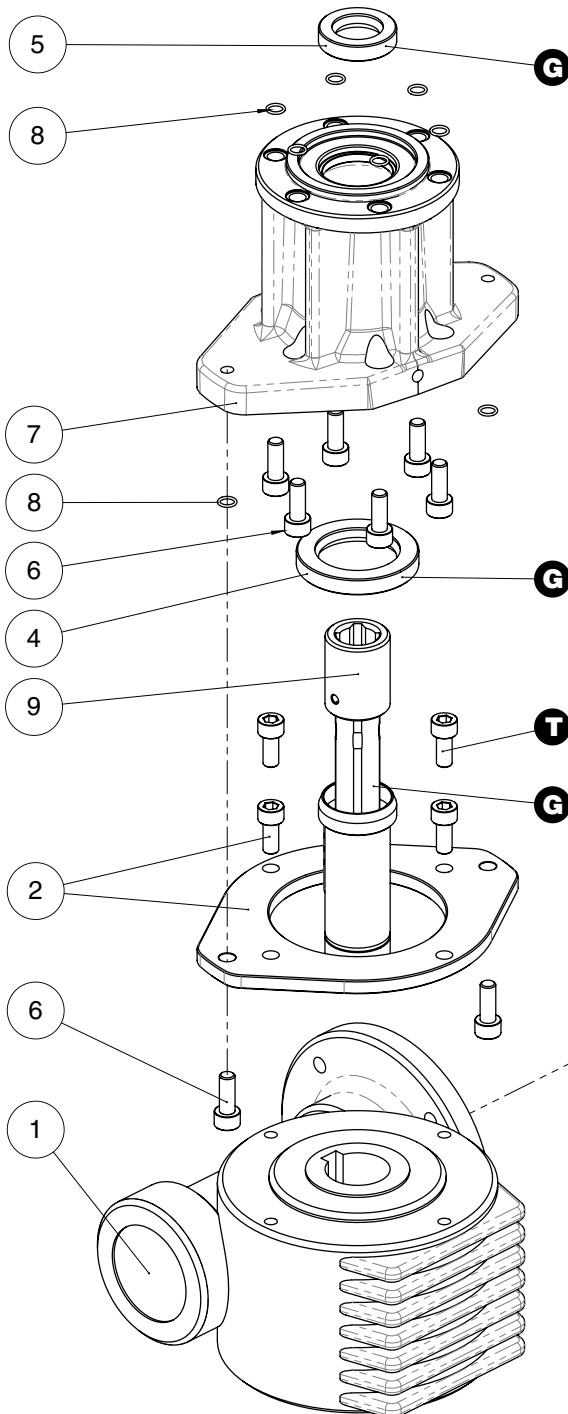

Pos	Q.ty	Code	Description
1	1	A93127900	KIT Gear Reduction 1/24
	1	A94194900	KIT LM Gear Reduction 1/24
2	1	A94149200	KIT Assy Electric Motor Flange
	1	A94149200L	KIT Assy Electric Motor Flange Left
	4	M0606803	Electric Motor Flange Screw M6x14 UNI 5931
3	1	A96010700	KIT EL Motor 12V 1,5kW
	1	A96010600	KIT EL Motor 24V 2kW
			Electric Motor Polarity motor sticker Screw stud M6x26 Washer Ø6 Nut M6 UNI5588
	1	M6014206	Key DIN 6885 5x5x15
4	1	M0612097	Sealer Ø30xØ47x7
5	1	M6007297	Lip seal Ø17xØ30x7
6	8	S415360003	Screw M6x16 UNI EN ISO 5931:2003 precote coating
7	1	S496650053	Horizontal Motorgear Flange
8	8	M6015697	O-Ring Seal ORM 0055-10 (Ø5,5 x Ø1)
9	1	A96589000	Performa KIT EL HO Motor Clutch
			Shaft Motorgear HO Performa HO Gear Motor Shaft Hub GearMotor
	1	M0601402	Dowel UNI EN ISO 8752:2000- Ø4x24
	1	M6020097	O-ring 19.1x1.6
	1	S418620001	Disconnect spring
	1	S414050080	Flange GearMotor Shaft HO
1	M6010303	Key 8x5x40 UNI 7511	

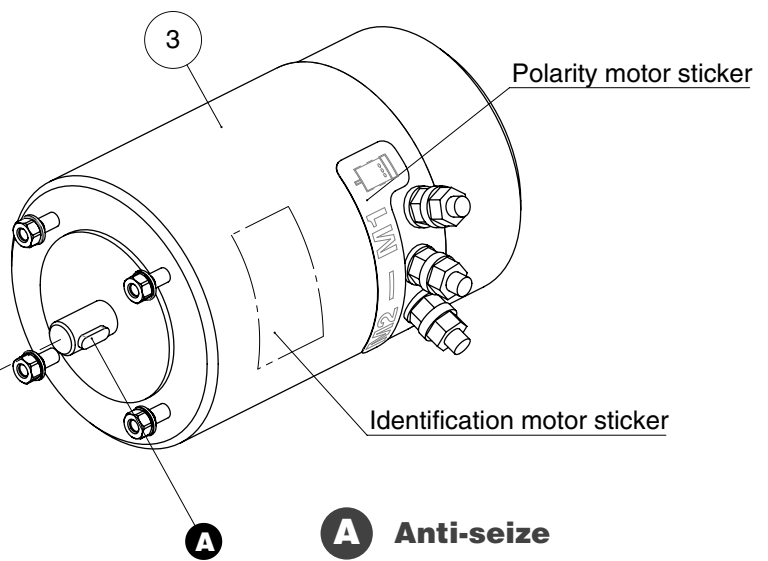

- A** **Anti-seize**
- G** **Harken® Grease**
- T** **Axial Threadlocker**

Vertical electric motor

Pos	Q.ty	Code	Description	Pos	Q.ty	Code	Description
1	1	A96010500	KIT EL Motor 12V 1,5kW VT	3	1	A94150500	KIT EL VT Motor Flange Vertical Motorgear Flange
	1	A96010400	KIT EL Motor 24V 2kW VT Electric Motor Polarity motor sticker Screw M8x20 UNI5931 Key DIN 6885 5x5x15		4	M0602903	NUT M8 - UNI 5588 - A4
	1	M6014206			4	M0603103	WASHER 8.4 U1751 DIN127 A4
	1	M6014206			1	M6007297	Lip seal Ø17xØ30x7
2	1	A96562900	Vertical reduction gear box 1/21.3	6	M6015697	O-Ring Seal ORM 0055-10 (Ø5,5 x Ø1)	
	1	A96562900		6	S415360003	Screw M6x16 UNI EN ISO 5931:2003 precote coating	
				4	M0606303	Screw M8x25 UNI 5931	
				4	1	A94193700	KIT EL VT Motor Clutch Connecting Coupling Ø31.5 Toothed coupling
					1	M0620401	Spring pin 5x40 DIN1481
					1	S326490001	Spring
					1	S415040080	Bushing
					1	S329360082	Washer
					1	M0666603	Screw M6x16 UNI 5933

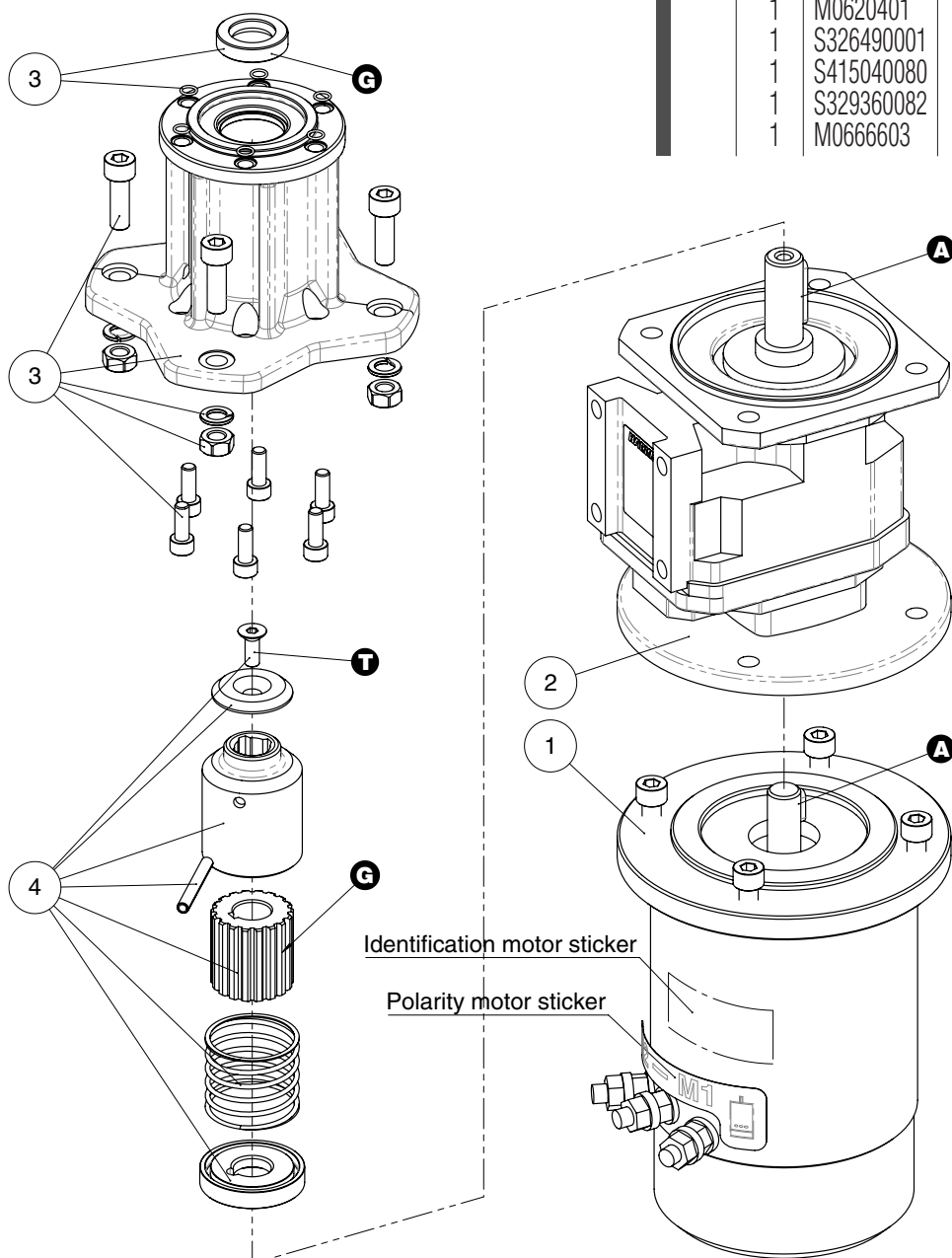

- A** Anti-seize
- G** Harken® Grease
- T** Axial Threadlocker

Hydraulic motor

Pos	Q.ty	Code	Description	Pos	Q.ty	Code	Description
1	1	G30848000Y	Hydraulic motor W70	4	1	A94149100	KIT HY Motor Flange W46-70
2	1	S415000080	Hydraulic Motor Spacer	6	1	S415360003	Hydraulic Motorgear Flange Screw M6x16 UNI EN ISO 5931:2003 precote coating
3	1	A94193200	KIT Clutch HY Motor W46-70	6	1	M6015697	O-Ring Seal ORM 0055-10 (Ø5,5 x Ø1)
			Toothed coupling	1	1	M6007297	Lip seal Ø17xØ30x7
			Connecting Coupling Ø31.5	2	1	M0621503	Washer D.13 U1751 DIN127
1	1	M0620401	Spring pin 5x40 DIN1481	2	1	M0667103	Screw M12x35 UNI5931
1	1	S415010080	Bushing				
1	1	S326490001	Spring				
1	1	S329360082	Washer				
1	1	M0635303	Screw M8x16 UNI6109				

