



RC12 Low Profile Model

Features and benefits

- The RC12 fully automatic windlass series is designed to effortlessly retrieve and deploy 10 mm (3/8") short link chain and 16 mm (5/8") to 20 mm (3/4") three strand or 8-Plait rope (RC12-10) and 13 mm (1/2") short link chain and 16 mm (5/8") to 20 mm (3/4") three strand or 8-Plait rope (RC12-12).
- Stainless steel AISI 316.
- With a maximum pull of 1590 kg (3500 lb), and an anchor retrieval rate of 15 m/min (50ft/min), the RC12-12 is one of the fastest and gruntest windlasses in its class.
- A sleek, Low Profile version and a fluted stainless steel (AISI 316) capstan drum version, are available.
- The all new RC12 is packed with patented innovative features combined with Maxwell's traditionally classic aesthetics, but reflecting the modern "form follows function" of the highly successful RC6, RC8 and RC10 series windlasses.
- The elegantly designed deckplate and chainpipe cover are manufactured in polished marine-grade (AISI 316) stainless steel, as are the heavy duty pressure arm, stripper, chainwheel and fluted capstan drum.
- The huge, through deck hawse pipe throat ensures easy entry of the rope/chain rode into and out of the anchor locker.
- Double cone-type brake/clutch mechanism permits 'Free Fall' anchoring. Cone clutches, unlike dog clutches, provide smooth progressive engagement, ensuring safe and precise operator control.
- The RC12 features Maxwell's revolutionary and patented new Wave Design™ chainwheel. Refer to RC6 page for more information about this innovative feature.
- Emergency manual retrieval is made simple and easy with Maxwell's unique "Active Latch Ratchet System" operation that prevents backwind of the windlass during manual hauling of the anchor.
- The Maxwell designed, all new and innovative black, hard anodised gearbox provides numerous advantages:
 - Fast and easy windlass installation
 - More corrosion resistant
 - Easy to maintain and service
 - Takes up less room in the anchor locker
 - 75:1 Ratio (RC12-10) or 100:1 Ratio (RC12-12), single stage design with less moving parts, for smoother and quieter operation
 - Allows for multi-positioning of the gearbox/motor.

The RC12 Series incorporates Maxwell's latest stylish innovation in automatic rope/chain windlass technology. Retaining the classic open design styling more appropriate on larger boats, the RC12-10 and RC12-12 represent the next generation of rope/chain windlass evolution in every respect.

SPECIFICATIONS

Model	RC12 (10/11 mm-3/8")	RC12 (12/13 mm-1/2")
Maximum Pull/Lift	1134 kg 2500 lbs	1590 kg 3500 lbs
Static Hold	2200 kg 4840 lbs	2200 kg 4840 lbs
Chain Short Link**	10/11 mm 3/8"	12/13 mm 1/2"
Rope Size (Nylon)** (3 strand or 8 plait recommended)	16-20 mm 5/8-3/4"	20 mm 3/4"
Chain Speed (at normal working load)	20 m/min 65 ft/min	15 m/min 50 ft/min
Rope Speed (at normal working load)	17 m/min 56 ft/min	13 m/min 43 ft/min
Power Supply (DC)	12 or 24 V	12 or 24 V
Motor Power	1200 W	1200 W
Net Weight - DC (Capstan version)	32 kg 71 lbs	32 kg 71 lbs
Net Weight - DC (Low Profile version)	29 kg 64 lbs	29 kg 64 lbs
Hydraulic Pressure	138 bar 2000 PSI	138 bar 2000 PSI
Hydraulic Flow	42 l/min 11 USgal/min	42 l/min 11 USgal/min
Net Weight - Hyd (Low Profile) (Capstan version)	23 kg/ 51 lbs 26 kg/ 57 lbs	23 kg/ 51 lbs 26 kg/ 57 lbs

** When ordering please specify your specific rope and chain, combination rode

DIMENSIONS

Model	RC12 (10 mm-3/8")	RC12 (12/13 mm-1/2")
A	293 mm 11 5/8"	293 mm 11 5/8"
B ¹ (Low Profile version)	128 mm 5 1/8"	128 mm 5 1/8"
B ² (Capstan version)	233 mm 9 1/4"	233 mm 9 1/4"
C	206 mm 8 1/8"	206 mm 8 1/8"
D (Std deck clearance)	210 mm 8 3/8"	210 mm 8 3/8"
E	294 mm 11 5/8"	294 mm 11 5/8"
F	482 mm 19"	482 mm 19"
G (Std deck clearance)	90 mm 3 5/8"	90 mm 3 5/8"
H	54 mm 2 1/4"	54 mm 2 1/4"
I	106 mm 4 1/4"	106 mm 4 1/4"
J	62 mm 2 1/2"	62 mm 2 1/2"

STANDARD EQUIPMENT REQUIRED

- FOR DUAL DIRECTION CONTROL**
- Dual Direction Solenoid (included)
 - Emergency (manual) retrieval handle (included)
 - Clutch release handle (included)
 - Up/Down remote control panel (not included)
 - Circuit breaker/isolator panel (not included)

OPTIONS

1. AutoAnchor™ Equipment
2. Compact Remote
3. Foot Switches
4. Chain Stopper
5. Chain Snubber
6. Capstan model

Every Maxwell RC12 automatic rope/chain windlass comes with top works, motor/gear box and dual direction solenoid. Switches and circuit breaker are available and need to be ordered separately. Refer chart on page 314.

HEIGHT MATCHED CHAIN STOPPER

- For use with Maxwell's rope/chain vertical windlasses
- Height adjusted to most effectively align chain with the chainwheel
- No height adjustment plinth required
- Refer to page 309 for more information



Height Matched Chain Stopper

Important: Maxwell windlasses must be used in conjunction with a chain stopper or alternative snubbing device to take the load off the windlass while laying at anchor. The chain stopper and alternative snubbing system should also be used to secure the anchor in the fully raised position while under way.

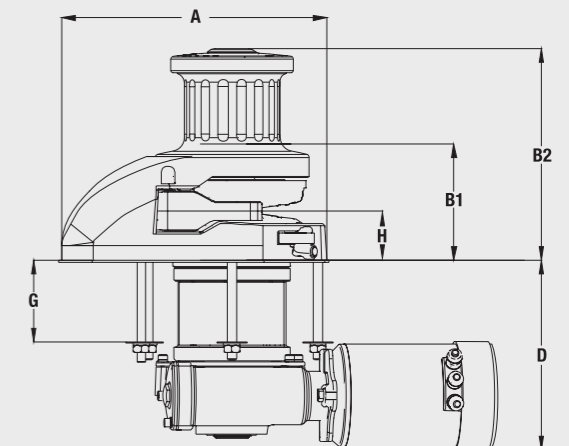
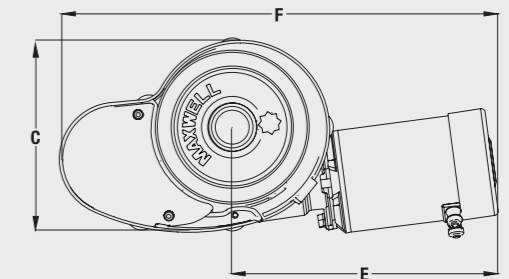

Activation of the ratcheted mechanism lever ensures the windlass can not backwind during emergency (manual) retrieval of the rode (rope and/or chain) and anchor.



3 YEAR
Limited Warranty

