



McLAY BOATS' 690

3 YEAR
Limited Warranty



RC8 Low Profile Version

- Unique spacer tube design allows installation through virtually any deck thickness and the multiple mounting positions and self aligning gearbox ensure optimal location of gearbox and motor in virtually all installation situations.
- The RC8 features Maxwell's revolutionary, and patented, Wave Design™ chainwheel. Refer RC6 page 285 for more information about this innovative feature.
- The heavy duty stainless steel (AISI 316) pressure arm is designed to effectively help grasp the rope/chain splice, giving the RC8 an unparalleled level of performance. In combination with a heavy duty, large wire diameter, stainless steel pre-loaded spring, the pressure arm always exerts maximum control pressure.
- The RC8 works just as effectively with all-chain rodes.
 - Huge, through deck hawse pipe throat ensures easy entry of the rope/chain rode into and out of the anchor locker.
 - Full disassembly capability of the topworks utilising only the handle provided and an Allen key.
 - Manual override and 'Free Fall', using the emergency crank/clutch handle provided.
 - Sealed oil bath and marine-grade hard anodised, alloy gearbox provides maximum output via a precision worm and worm wheel.

SPECIFICATIONS

Model	RC8 (6/7 mm-1/4")	RC8 (8 mm-5/16")
Maximum Pull/Lift	350 kg 770 lbs	600 kg 1320 lbs
Static Hold	1200 kg 2640 lbs	1200 kg 2640 lbs
Chain Short Link	6 mm/7mm 1/4"	8 mm 5/16"
Rope Size (Nylon)* (3 strand or 8 plait recommended)	12 mm 1/2"	14 mm-16mm 9/16"-5/8"
Chain Speed (Anchor Retrieval)	28 m/min 92 ft/min	32 m/min 105 ft/min
Rope Speed (Anchor Retrieval)	24 m/min 79 ft/min	28 m/min 92 ft/min
Power Supply (DC)	12 or 24 V	12 or 24 V
Motor Power	600 W	1000 W
Net Weight	12.5 kg 27.5 lbs	16.5 kg 36.3 lbs

* refer to owners manual for rope size variations.

DIMENSIONS

Both Models	RC8 (6/7 mm-1/4")	RC8 (8 mm-5/16")
A	210 mm 8 5/16"	210 mm 8 5/16"
B1	83 mm 3 5/16"	83 mm 3 5/16"
B2 (with Capstan)	146 mm 5 3/4"	146 mm 5 3/4"
C	156 mm 6 3/16"	156 mm 6 3/16"
D	200 mm 7 7/8"	208 mm 8 1/4"
E	245 mm 9 5/8"	272 mm 10 3/4"
F	383 mm 15"	410 mm 16 1/4"
G (Std deck clearance) ^	65 mm 2 1/2"	65 mm 2 1/2"
H	40 mm 1 5/8"	40 mm 1 5/8"
I	66 mm 2 5/8"	66 mm 2 5/8"
J	44 mm 1 3/4"	44 mm 1 3/4"

^ extra deck clearance models available. Contact your Maxwell dealer.

STANDARD EQUIPMENT REQUIRED FOR DUAL DIRECTION CONTROL

- Dual Direction Solenoid (included)
- Emergency crank/clutch release handle lever (included)
- Up/Down remote control panel (not included)
- Circuit breaker/isolator panel (not included)

OPTIONS

1. AutoAnchor™ Equipment
2. Compact Remote
3. Foot Switches
4. Chain Stopper
5. Chain Snubber
6. Capstan model

Every Maxwell RC8 automatic rope/chain windlass comes with the top works, gear box, motor and dual-direction solenoid. Switches and circuit breaker are available and need to be ordered separately. Refer chart on page 314.

HEIGHT MATCHED CHAIN STOPPER

- For use with Maxwell's rope/chain vertical windlasses
- Height adjusted to most effectively align chain with the chainwheel
- No height adjustment plinth required
- Refer to page 309 for more information



Height Matched Chain Stopper

The stainless steel (AISI 316) RC8 Series of automatic rope/chain anchor winches are Maxwell's mid-range models in the highly success RC Series Windlass Range.

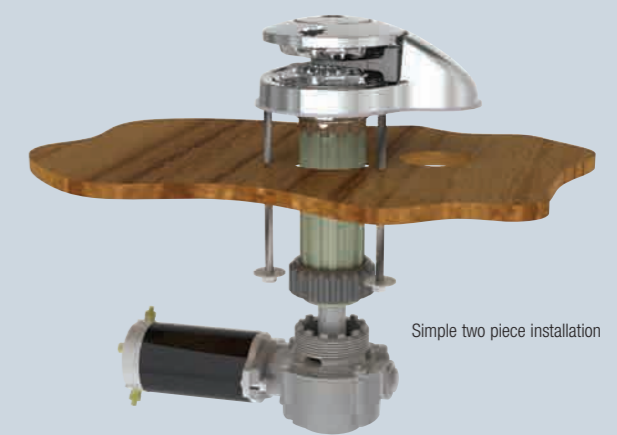
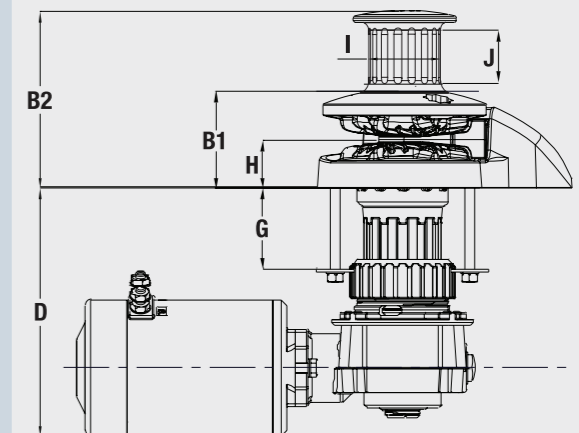
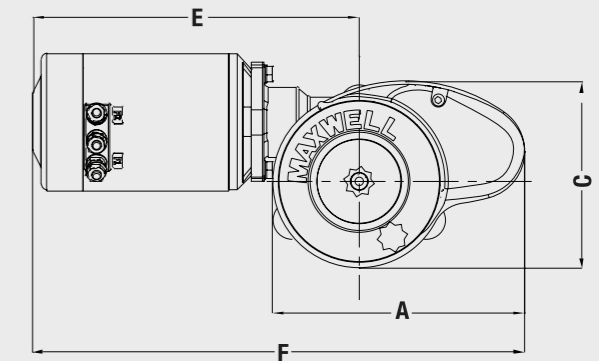

Simple two piece installation

Important: Maxwell windlasses must be used in conjunction with a chain stopper or alternative snubbing device to take the load off the windlass while laying at anchor. The chain stopper and alternative snubbing system should also be used to secure the anchor in the fully raised position while under way.

Features and benefits

- The stainless steel (AISI 316) RC8-6 Series incorporates a chromed bronze chainwheel, designed to effortlessly retrieve and deploy 6 mm/7 mm (1/4") chain spliced to 12 mm (1/2") three strand or 8-brait (plait) rope.
- The more powerful RC8-8 can be used with 8 mm (5/16") chain spliced to 16mm (5/8") three strand or 8-plait rope.
- The ingenious Wave Design™ rope/chain gypsy (chainwheel) is able to accommodate a wide range of chain pitch differences within the specified chain size diameters suitable for use with the RC8 Series.
- A sleek, Low Profile version and a fluted stainless steel capstan drum version, are available.
- Simple two piece installation saves time and money and allows easy retrofitting without disassembly of the windlass.



RC8 with gearbox and motor

