

AL3 Series

REV 000A



VERTICAL WINDLASSES

AL3_P 712

AL3_P 724

AL3_P 1012

AL3_P 1024

AL3 1512

AL3 1524

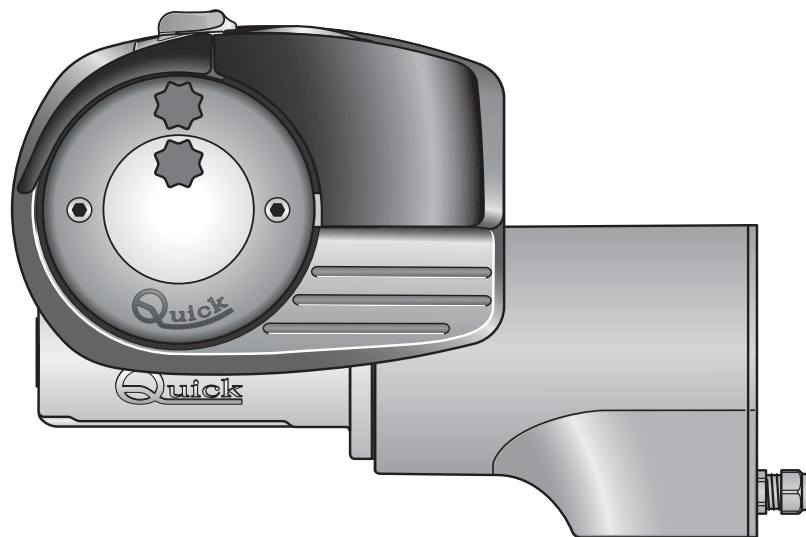
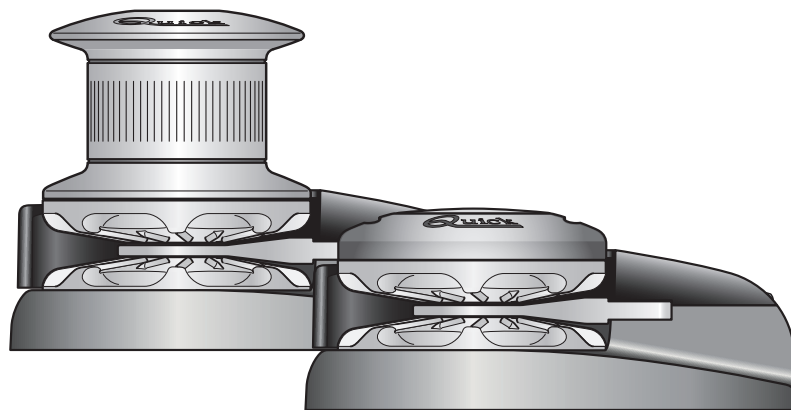

***EN - INSTALLATION AND USER'S MANUAL**

*Other languages available by scanning the QR code on the back of this manual or on the label on the product.

Quick[®]
Nautical Equipment

1 - Information about the product	5
1.0 - Model code	5
1.1 - Technical Data	5
2 - Supply and equipment	6
2.0 - Standard supply and material included in the package	6
2.1 - Tools required for installation	6
2.2 - Recommended Quick® accessories not included	6
3 - Introduction	6
3.0 - Important notes	6
3.1 - Precautions	7
3.2 - Precautions for the installer	7
4 - Installation	7
4.0 - Installation requirements	7
4.1 - Installation procedures	8
4.2 - Flange mounting AL3 700W - 1000W	9
4.3 - Motorgearbox rotation	9
5 - Wiring diagram	10
5.0 - Example of connection AL3 Series 700W P - 1000W P - 1500W	10
6 - Cautions & Use	11
6.0 - Important cautions	11
6.1 - Clutch use	11
6.2 Drum use	12
6.2 - Troubleshooting	13
7 - Maintenance	13
8 - Product disposal	13
9 - List of components	14
10 - Spare parts	16

2.0 - Standard supply and material included in the package

- Windlass (top+gearmotor)
- Contactor box
- Base gasket
- Lever
- Screws for assembly
- Manual anchor weighing (no drum version)
- Installation and user's manual, Warranty
- Drilling template

2.1 - Tools required for installation

- Drill with bit: Ø 9 mm (23/64") e Ø 11 mm (7/16")
- Hole saw 75 mm (2"7/8)
- Hex wrench: 13 mm

2.2 - Recommended Quick® accessories not included

- Controls for control board (Serie WCS)
- Waterproof push-button panel (HRC 1002)
- Foot switch (900)
- Hydraulic-magnetic circuit breaker (WCB)
- Anchor chain counter (CHC 1203, CHC 1103, QNC CHC)
- Control system via RRC radio (R02 - P02 - H02)

3 - Introduction

BEFORE USING THE PRODUCT, PLEASE READ THIS USER'S MANUAL CAREFULLY. IF IN DOUBT, PLEASE CONSULT YOUR QUICK® DEALER.

3.0 - Important notes

This manual features Warning and/or Caution symbols that are important for safety. Please follow the instructions provided.



Warning symbol indicating dangerous situations.



Caution symbol to prevent direct or indirect damage to the product.

This manual provides boat manufacturers and nautical equipment installers with instructions on how to assemble the specified Quick® product and operate it correctly.



3.1 - Precautions



Quick® windlasses are designed and manufactured to weigh the anchor.

- Do not use these products for any other type of operation.
 - Quick® shall not be held liable for direct or indirect damage caused by improper use of the product.
 - The windlass is not designed to support loads generated in particular weather conditions (storm).
 - Operate the product from a position where it is possible to supervise the work area.
 - Always deactivate the windlass when not being used.
 - Make sure that there are no bathers nearby before dropping the anchor.
 - The splice between the rope and the chain must be tightly woven for the rope to slide easily into the gypsy shape.
- For any problem or request, feel free to contact Quick® Technical Service.
- For improved safety, we recommend installing at least two controls to operate the windlass in case one is damaged.
 - We recommend the use of Quick® switch as motor safety device.
 - Secure the chain with a retainer before sailing off.
 - The reversing contactor box must be installed in a position protected from any water entry.
 - After completing the anchorage, secure the chain to fixed points such as chain stopper or bollard.
 - To prevent accidental releases, the anchor must be secured. The windlass must not be used as sole securing device.
 - Isolate the windlass from the electrical system during navigation and secure the rope to a fixed point of the boat.
 - This equipment is not intended for use by people (including children) with reduced physical, sensory or mental capabilities.

3.2 - Precautions for the installer



CARRY OUT THE INSTALLATION IN GOOD LIGHTING CONDITIONS.

It is advisable to wear suitable clothing and personal protective equipment (PPE).

The product is not suitable for installation in potentially explosive environments and/or atmospheres. Installation and subsequent inspection or repair work must only be carried out by qualified personnel.



CARRY OUT INSTALLATION/MAINTENANCE WORK MAKING SURE THAT THE PRODUCT IS DISCONNECTED FROM THE ELECTRICAL SYSTEM.

Quick® accepts no responsibility for inadequate connection of users to the electrical system and inadequate safety of the electrical system.



4.0 - Installation requirements

A ROLLER ALIGNMENT

The windlass must be positioned by aligning the gypsy with the bow roller (fig. 1A / 2A).

Precise alignment of the windlass is essential for the correct operation of the product.

A positive chain tilt of up to 10° is allowed (fig. 2A).

An excessive negative tilt of the chain could interfere with the windlass base (fig. 3A / 4A)..

1A

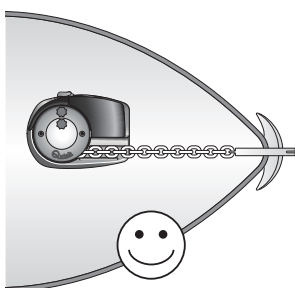

2A

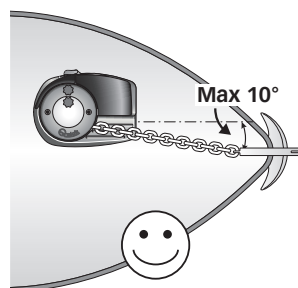

3A

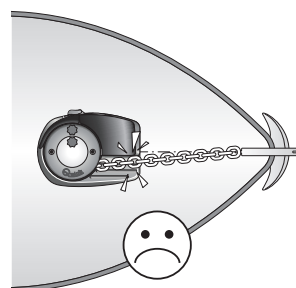

4A

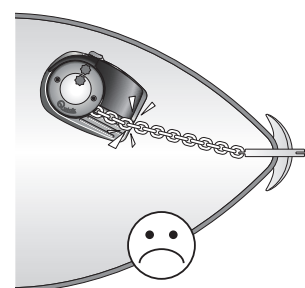

**B DECK LEVEL**

Ensure that the upper and lower surfaces of the deck are as parallel as possible. If this is not the case, compensate the difference appropriately (fig. B).

A lack of parallelism could result in a loss of motor power. The deck thickness must be included among the figures listed in the table.

In case of different thickness, please contact your Quick® dealer.

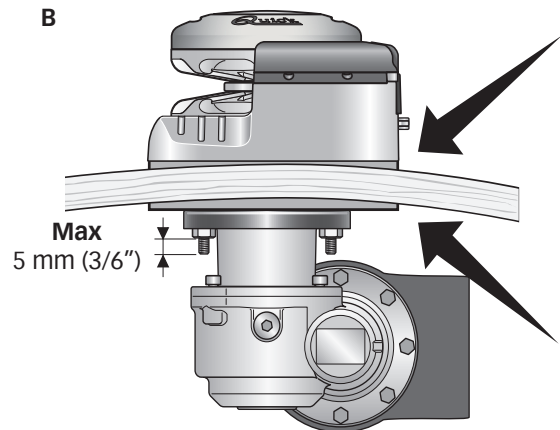
**C PEAK DEPTH AND BOW ROLLER HEIGHT**

There must be no obstacles to the passage of cables, rope and chain under deck (fig. 1C). Insufficient depth of the peak could cause chain jamming (fig. 2C).

A positive tilt of the chain in relation to the deck level of up to 5° is allowed (fig. 1C).

An excessive negative tilt of the chain could interfere with the windlass base (fig. 2C).

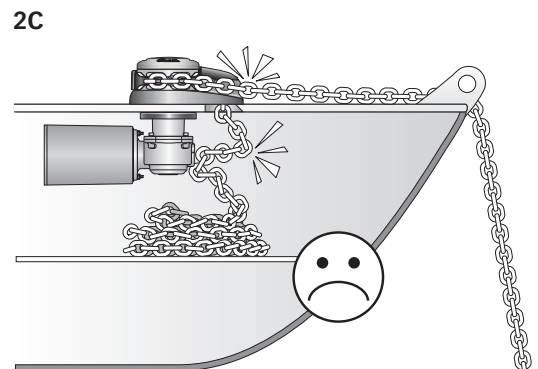
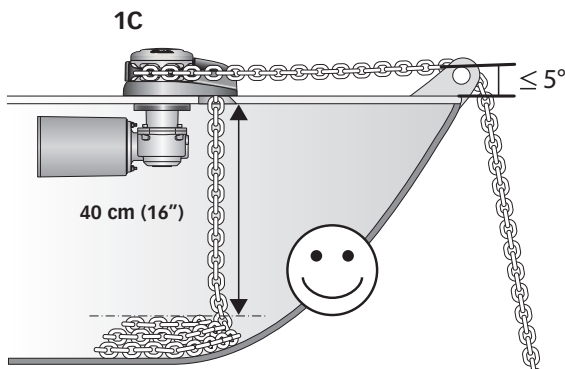
**4.1 - Installation procedures**

A Identify the ideal position and drill the holes using the drilling template supplied.

B Remove the excess material from the rope/chain passage hole, finish it and smooth it with a specific product (marine paint, epoxy resin or gel) ensuring the free passage of the chain.

C Position the upper section inserting the gasket between the deck and the base, and connect it to the lower section inserting the shaft into the gearbox. Fix the windlass by screwing the nuts onto the fixing studs.

Connect the supply cables from the windlass to the reversing contactor unit.

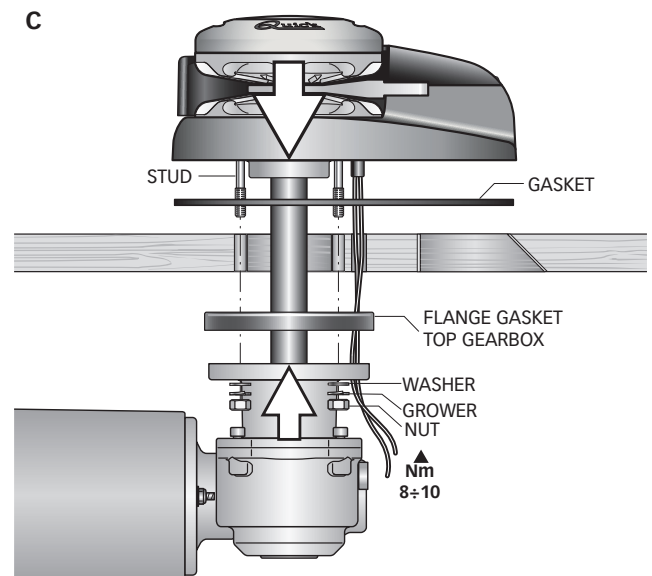
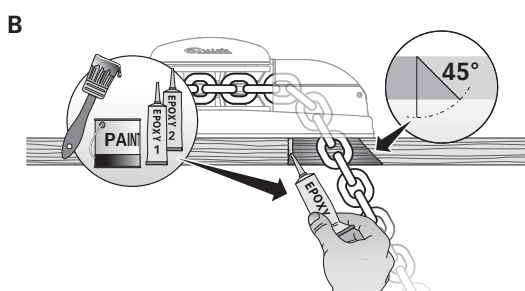
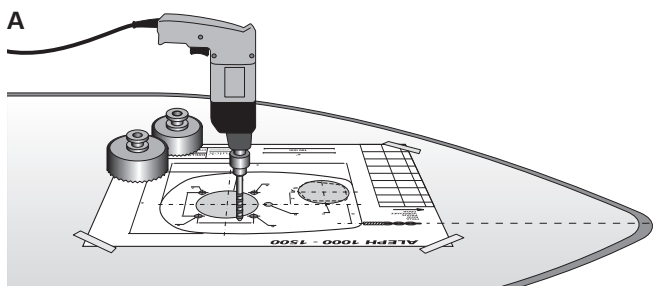



4.2 - Flange mounting AL3 700W - 1000W

Flange **A** can be fixed on both sides of gearbox **B**.

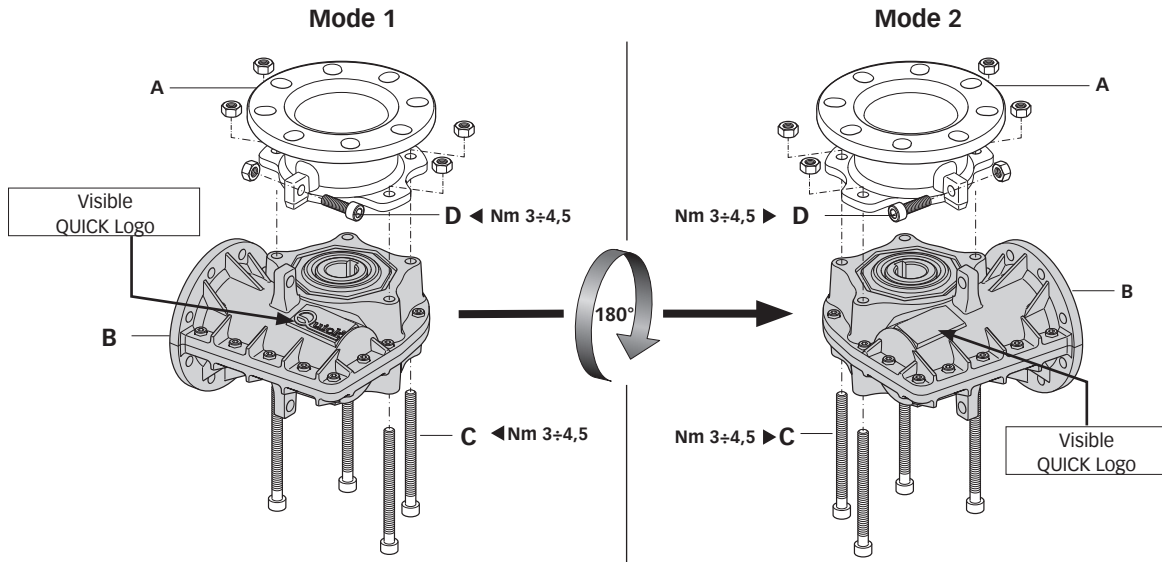

To change from mode 1 to mode 2 unscrew screws **C** and **D** and separate the two parts **A** and **B**, turn gearbox **B** by 180° and reassemble it with screws **C** and **D**.

The two modes allow greater versatility in mounting the motorgearbox, while maintaining the same overall dimensions.

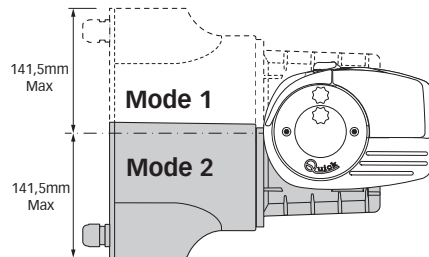

4.3 - Motorgearbox rotation

It is possible to rotate the motorgearbox every 45° in relation to the base of the windlass. Possible motorgearbox positions:

Motorgearbox 700W/1000W

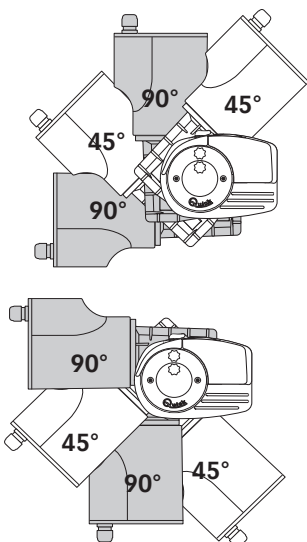

Motorgearbox 1500W

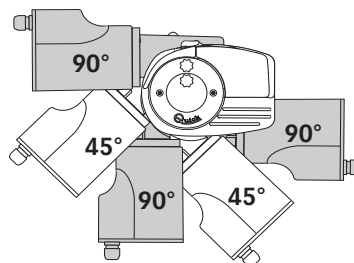



5.0 - Example of connection AL3 Series 700W P - 1000W P - 1500W P with recommended Quick® accessories for the operation of the windlass

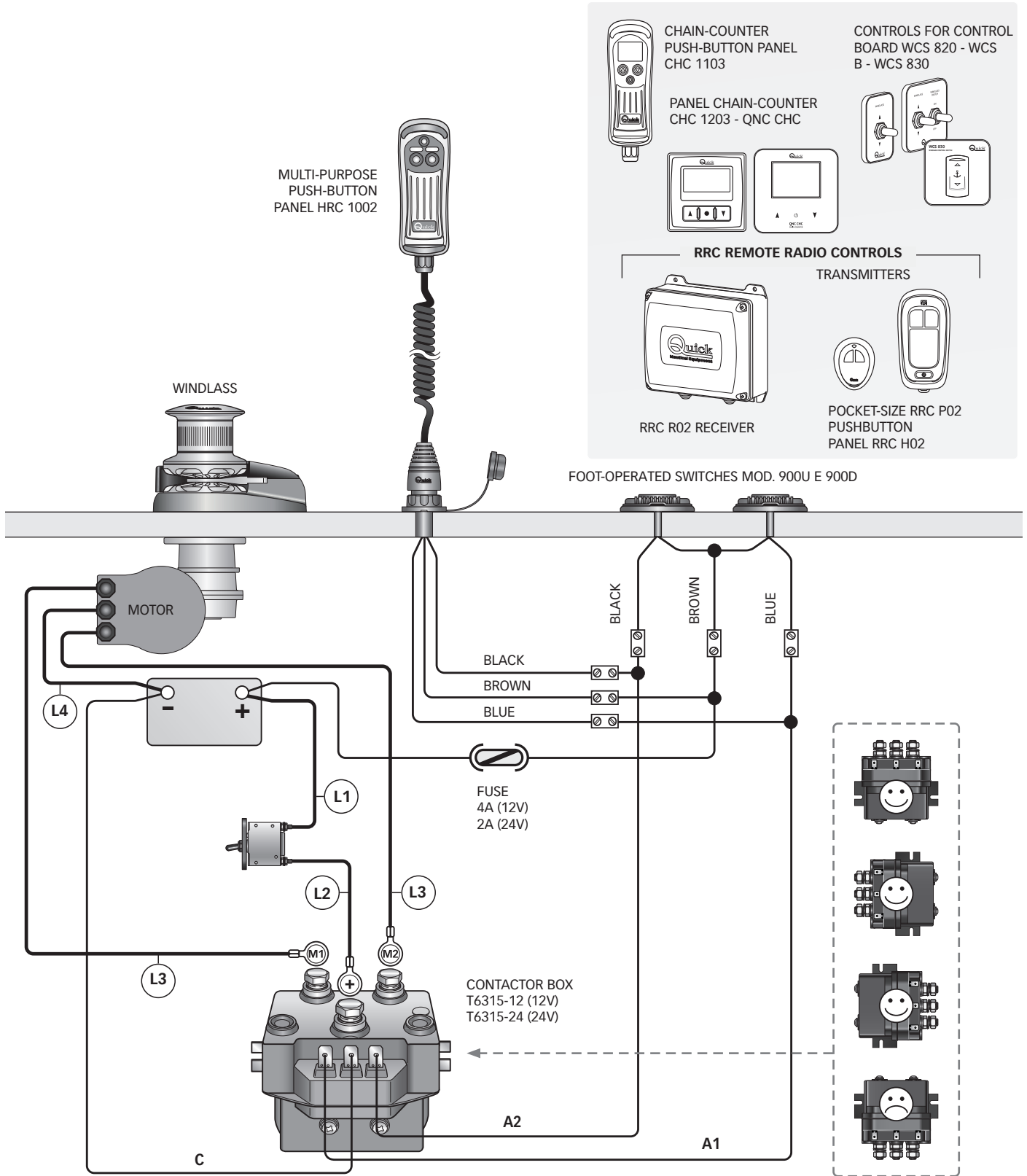

$L = (L1) + (L2) + (L3) + (L4)$



6.0 - Important cautions



- Stay clear of chains, ropes and gypsy.
- Operate the windlass from a position where it is possible to supervise the work area
- Make sure the electric motor is not powered when the windlass is used manually (even when using the handle to disengage the clutch), because people with windlass remote controls (remote push-button panel or radio control) might accidentally operate it.
- Secure the chain with a retainer before sailing off.
- DO NOT operate the windlass by using the electrical power when the handle is inserted in the drum or into the gypsy cover.



- Quick® recommends using a suitable power fuse/thermal-magnetic/hydraulic-magnetic protection for the motor used, to protect the motor from overheating or short circuits.
- The circuit breaker can be used to isolate the windlass control circuit, thus avoiding accidental activation.

6.1 - Clutch use

The clutch (B) provides a link between the gypsy and the main shaft (A). The clutch can be released (disengagement) by using handle (C) which, when inserted into bush (D) of the drum or into the gypsy cover (E), must be turned counter-clockwise. The clutch will be re-engaged by turning it clockwise.

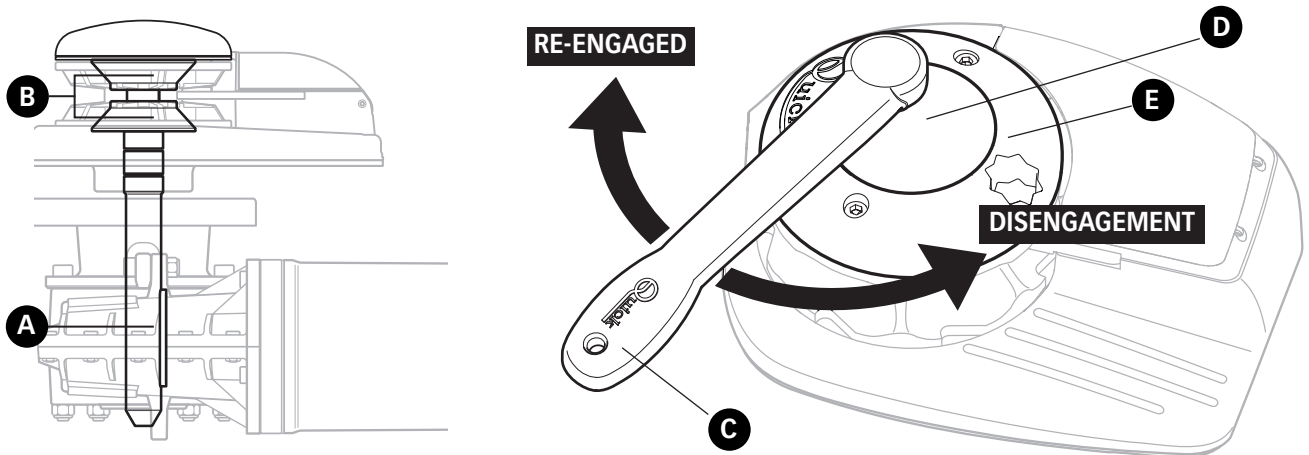

WEIGHING THE ANCHOR

- 1 Turn on the boat engine.
- 2 Make sure the clutch is engaged and remove the handle.
- 3 Press the UP button on the control provided.



Check the upward movement of the chain for the last few meters in order to avoid damage to the bow.

CASTING THE ANCHOR

The anchor can be cast by using the electrical controls or manually.

Manually

The clutch must be disengaged allowing the gypsy to revolve and letting the chain or rope fall into the water. To slow down the chain, the handle must be turned counter-clockwise.

Electrically

To cast the anchor by using the electrical power, press the DOWN button on the control provided. In this manner, anchor casting is under control and the chain unwinds evenly.



In order to avoid any stress on the windlass once the boat is anchored, fasten the chain or secure it to a firm hold with a rope.



MANUAL ANCHOR WEIGHING (no drum version)

- 1 Disconnect the windlass power supply.
- 2 Use the lock lever control (F/G) to engage the lock lever (H) on the gypsy.
- 3 Disengage the clutch (at least 2 turns of the bush anticlockwise), insert the lever (C) into the seat in the gypsy cover (E) and manually take up the chain by rotating the lever (C) clockwise.

After the manual weighing procedure remove the lever (C) from its seat and insert it into the bush (D) to tighten the clutch. Remove the lever (C) from the gypsy cover (E). Release the gypsy using the control lever (F/G). Reconnect the windlass power supply.

MANUAL ANCHOR WEIGHING (drum version)

- 1 Disconnect the windlass power supply.
- 2 Use the lock lever control (F/G) to engage the lock lever (H) on the gypsy. Use the lever (C) to completely loosen the bush, pull off the drum and mount the manual anchor weighing on the gypsy with the corresponding screws. Insert the lever (C) into the seat in the anchor weighing (I) and manually take up the chain by rotating the lever clockwise.
- 3 After the manual weighing (I) procedure, remove the lever from its seat, reinsert the drum and tighten the drum to tighten the clutch.

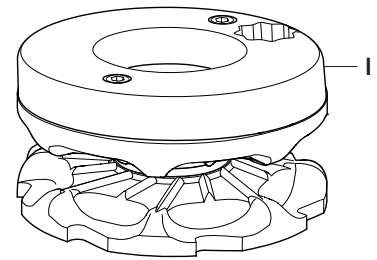

 during take up maintain a safe distance between hands and windlass drum.

Once take up is complete, screw up the clutch by tightening the gypsy drum clockwise and secure the rope to a bitt or other strong point on the boat.

6.2 Drum use



WARNING: Before carrying out warping operations, check that the anchor and relative rope or chain are solidly fixed to a bitt or another strong point on the boat.

For the independent use of the drum, turn the lock lever control (F/G) to engage the lock lever (H) of the gypsy, release the clutch with the handle (C), (at least 2 turns of the bush anticlockwise). Remove the handle from the bush on the gypsy, wrap the rope around the drum (at least 3 turns). Activate the windlass control, keeping the rope under tension during take up. By varying the tension during take up it is possible to modify the rope winding speed.



WARNING: during take up maintain a safe distance between hands and windlass drum.

Once take up is complete, screw up the clutch by tightening the gypsy drum clockwise and secure the rope to a bitt or other strong point on the boat.



WARNING: before weighing anchor release the gypsy.

Check that the control (F/G) that locks the gypsy is disengaged.

- 1 Release the gypsy safety lock (H).
- 2 Have the gypsy lock control slide toward the stern.
- 3 Automatic inserting of the gypsy lock (H).

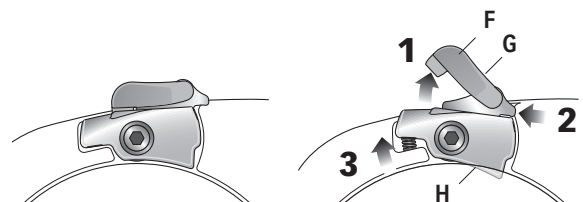

LOCK DISENGAGED

LOCK ENGAGED



6.2 - Troubleshooting

If the windlass stops and the hydraulic magnetic (or thermal magnetic*) switch has not tripped, wait a few seconds and try again (avoid keeping the button pressed).

If the hydraulic magnetic switch, has tripped, reset it and wait a few minutes before weighing anchor once again.

If, after a number of attempts, the windlass is still blocked, we suggest to move the boat to release the anchor.



WARNING: make sure the electrical power to the motor is switched off when working manually on the windlass. Carefully remove the chain from the gypsy or the rope from the drum.

Quick® windlasses are made of materials resistant to the marine environment: it is essential, in any case, to periodically remove salt deposits that form on the external surfaces to avoid corrosion and consequently damage to the device. Thoroughly wash the surfaces and parts where salt can deposit with fresh water.

Once a year, disassemble the gypsy and the drum according to the following sequence:

Drum version

- Use the handle (1) to loosen the bush (7); pull off the drum (6)
- Remove the top clutch cone (11)
- Undo the retaining screws (10) to remove the chain stripper (14)
- Remove the gypsy (12)
- Remove the bottom clutch cone (13)

No-drum version

- Use the handle (1) to loosen the clutch bush (2), screw (5), gypsy cover (4)
- Remove the top clutch cone (11)
- Undo the retaining screws (10) to remove the chain stripper (14)
- Remove the gypsy (12)
- Remove the bottom clutch cone (13)

Clean all the parts removed to avoid corrosion, and grease (with marine grease) the shaft thread and the gypsy where the clutch cones rest.

Remove any oxide deposits from the terminals of the electric motor and the reversing contactor unit; grease them.



If required, windlass must be disassembled by qualified personnel.

Make sure that the gearmotor is cold before disassembling it.

The disposal must be carried out according to the regulations of the place where the work is carried out.



As with installation, at the end of this product life, dismantling must be carried out by qualified personnel.

This product is made up of various materials, some can be recycled and others must be suitably disposed of; enquire about the recycling or disposal systems provided for by local regulations for this product category.

Some parts of the product may contain pollutants or hazardous substances that, if dispersed, may be harmful to the environment and human health.



As indicated by the symbol on the side, it is forbidden to dispose of this product as domestic waste.

Separate the products for disposal in accordance with the regulations in force in your area or return the product to the seller when purchasing a new equivalent product. Local regulations may impose severe penalties for the improper disposal of this product.

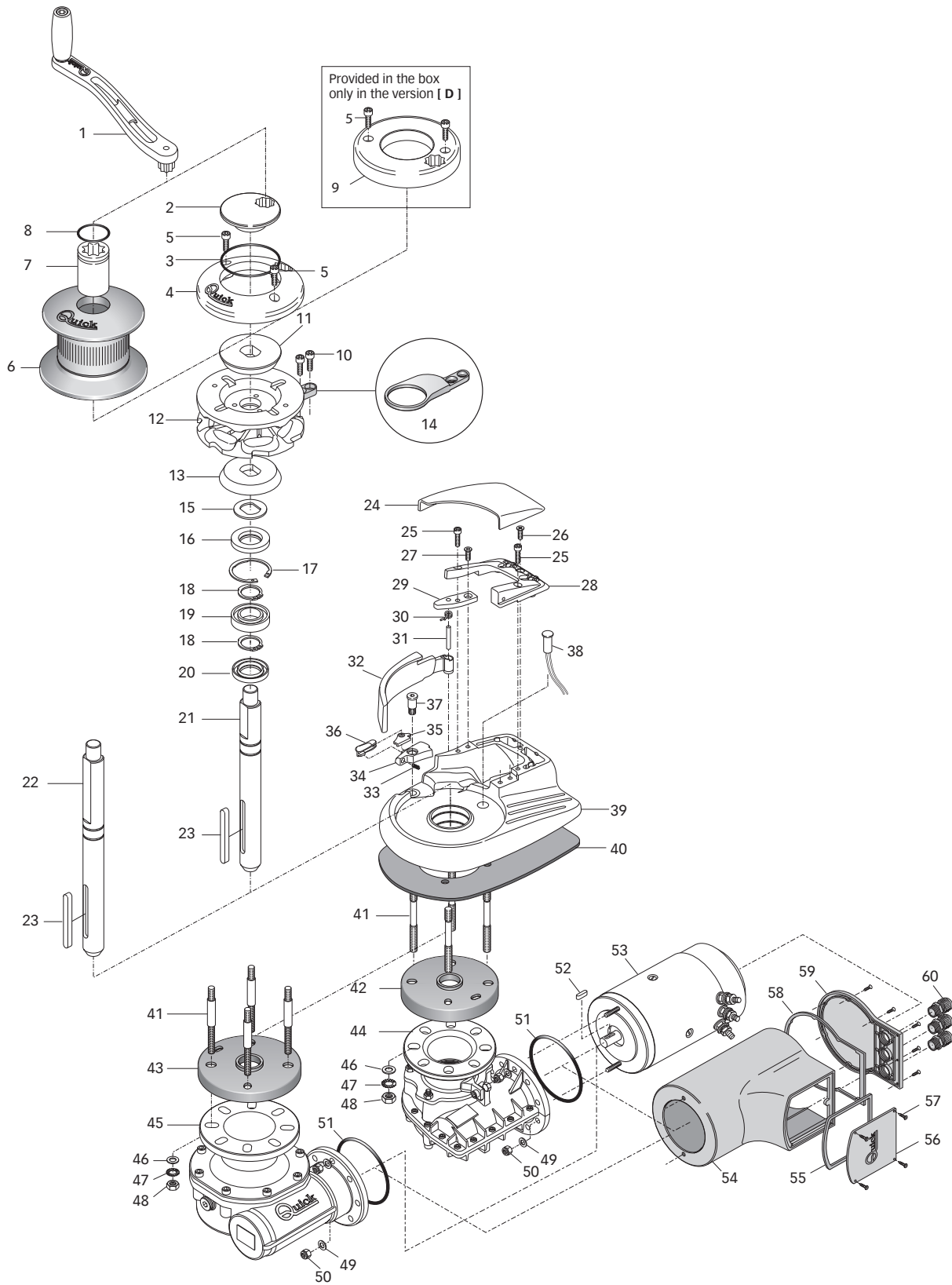



N°	NAME				
1	CURVED WINDLASS LEVER	22	LONG SHAFT	45	GEARBOX - QUICK TG70 1500W
2	CLUTCH CHROMED	23	KEY	46	WASHER
3	O-RING	24	"AL" CHAIN FALL COVER	47	SERRATED WASHER
4	GYPSY COVER	25	SCREW	48	NUT
5	SCREW	26	SCREW	49	WASHER
6	INOX DRUM	27	SCREW	50	SELF-LOCKING NUT
7	CHROMED DRUM	28	CHAIN FALL COVER SUPPORT	51	O-RING
8	O-RING	29	MOORING ROPE PULLER	52	KEY
9	INSERT FOR MANUAL ANCHOR WEIGHING	30	PRESSURE LEVER SPRING	53A	MOTOR 700W 12V
10	SCREW	31	MOORING ROPE PULLER PIN	53B	MOTOR 700W 24V
11	TOP CONE	32	PRESSURE LEVER	53C	MOTOR 1000W 12V
12A	GYPSY 1000W 8MM - 5/16"	33	GYPSY LOCK SPRING	53C	MOTOR 1000W 24V
12B	GYPSY 1000W 10MM - 3/8"	34	GYPSY LOCK LEVER	53D	MOTOR 1500W 12V
13	BOTTOM CONE	35	GYPSY LOCK LEVER CONTROL	53E	MOTOR 1500W 24V
14	INOX CHAIN STRIPPER	36	LEVER LOCK CONTROL SAFETY	54A	CARTER 700W
15	SHAPED WASHER	37	GYPSY LOCK PIN	54B	CARTER 1000W
16	OIL SEAL	38	SENSOR	55	TERMINAL BOARD GASKET 1000W
17	INTERNAL SNAP RING	39	BASE	56	TERMINAL BOARD COVER 1000W
18	EXTERNAL SNAP RING	40	GASKET ALEPH	57	SCREW
19	BEARING	41	STUD	58	BOTTOM GASKET 1000W
20	OIL SEAL	42	GEARBOX FLANGE GASKET TOP TG50	59	BOTTOM COVER 1000W
21	SHORT SHAFT	43	GEARBOX FLANGE GASKET TOP TG50	60	CABLE GLAND
		44	GEARBOX - QUICK TG50 1000W		



Refer to the exploded drawing on page.14

CODE	DESCRIPTION	NUMB. OF PARTS
FVSSRM100000A00	OSP INSERT MANUAL ANCHOR WEIGHING 1000W	5 - 9
FVSSGMSDP300000	OSP DRUM BUSH "SERIES AL3"	7 - 8
FVSSMSE10AL0A00	OSP WINDLASS DRUM 1000W AL	6
FVSSMSE10000A03	OSP WINDLASS DRUM 1000W COMPLETE R03	6 - 7 - 8
FVSSSTAL10D08A00	OSP TOP ALEPH 7/10/1500W D 8MM-5/16"	da 6 a 8 - da 10 a 20 - da 22 a 41 - da 46 a 48
FVSSSTAL10D10A00	OSP TOP ALEPH 7/10/1500W D 10MM-3/8"	
FVSSAAL1000DA00	OSP SHAFT KIT AL 1000 D	da 16 a 20 - 22 - 23
FVSSAAL10000A00	OSP SHAFT KIT AL 1000	da 16 a 21 - 23
FVSSLVSP00R1A00	OSP CURVED WINDLASS LEVER R01	1
FVSSGMSDFRAL000	OSP OSP CLUTCH BUSH SERIES AL	2 - 3
FVSSCPBBAL00A00	OPS GYPSY COVER ALEPH	4 - 5
FVSSSTAL10008A00	OSP TOP ALEPH 7/10/1500W 8MM-5/16"	da 6 a 8 - da 10 a 21 - da 23 a 41 - da 46 a 48
FVSSSTAL10010A00	OSP TOP ALEPH 7/10/1500W 10MM-3/8"	
FVSSSTCAL0000A00	OSP PRESSURE LEVER KIT ALEPH	27 - da 29 a 32
FVSSCPSCAL00A00	OSP CHAIN GUIDE COVER KIT AL	24 - 25 - 26 - 28
FVSSB100851TA00	OSP GYPSY 1000W 8MM-5/16" AT/AL	10 - 12 - 14
FVSSB101038TA00	OSP GYPSY 1000W 10MM-3/8" AT/AL	
FVSSCFANHC00A00	OSP CLUTCH CONES AT/HC/AL/DP3	11 - 13
FVSSBLBDN00A00	OSP KIT GYPSY LOCK DN/AL	da 33 a 37
FVSSBAL10C00A00	OSP WINDLASS BASE 1000W SERIES AL COMP	da 24 a 41 - da 46 a 48
FVSSMR10TG50B00	OSP GEARBOX 1000W WINDLASS QUICK R1	42 - 44 - da 46 a 51
FVSSMR15TG70A00	OSP GEARBOX 1500W WINDLASS QUICK TG70	43 - da 45 a 51
FVSSR0712Q00B00	OSP MOTORGearBOX 700W 12V QUICK R1	42 - 44 - da 46 a 60
FVSSR1012Q00B00	OSP MOTORGearBOX 1000W 12V QUICK R1	
FVSSR0724Q00B00	OSP MOTORGearBOX 700W 24V QUICK R1	
FVSSR1024Q00B00	OSP MOTORGearBOX 1000W 24V QUICK R1	
FVSSR1512Q00A00	OSP MOTORGearBOX 1500W 12V QUICK	43 - 45 - da 46 a 60
FVSSR1524Q00A00	OSP MOTORGearBOX 1500W 24V QUICK	
FVSSM0712000A00	OSP WINDLASS MOTOR 700W 12V	da 49 a 60
FVSSM0724000A00	OSP WINDLASS MOTOR 700W 24V	
FVSSM1012000A00	OSP WINDLASS MOTOR 1000W 12V	
FVSSM1024000A00	OSP WINDLASS MOTOR 1000W 24V	
FVSSM1512000A00	OSP WINDLASS MOTOR 1500W 12V	da 49 a 60
FVSSM1524000A00	OSP WINDLASS MOTOR 1500W 24V	

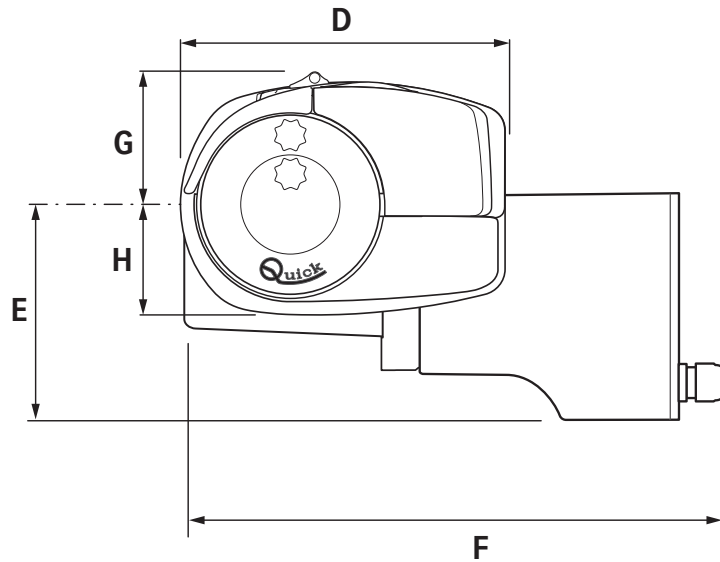
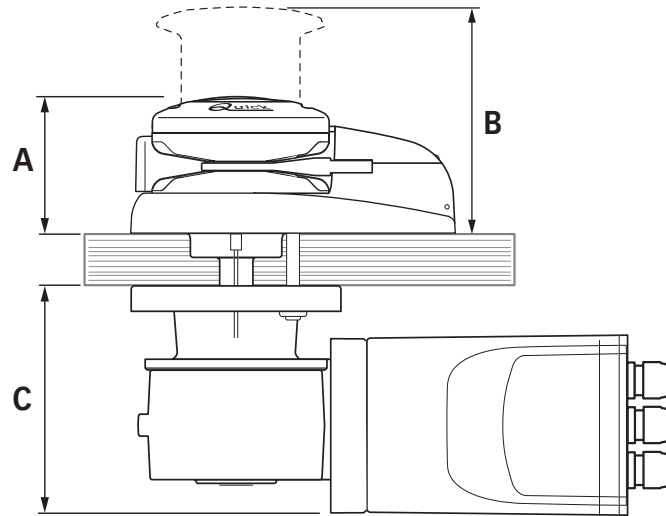

AL3Series (-/D)	AL3 P 700W	AL3 P 1000W	AL3 1500W
A	102 (4" 1/64)		
B DRUM	169 (6" 21/32)		
C	155,4 (6 1/8)	170,4 (6" 45/64)	
D	239 (9" 13/32)		
E	141,5 (5" 27/32)		161,5 (6" 23/64)
F	340 (13" 25/64)	355 (13" 31/32)	385 (15" 5/32)
G	98 (3" 55/64)		
H	81 (3" 3/16)		



A series of horizontal dotted lines for taking notes.



A series of horizontal dotted lines for taking notes.

AL3 Series

REV 000A



AL3_P 712

AL3_P 724

AL3_P 1012

AL3_P 1024

AL3 1512

AL3 1524

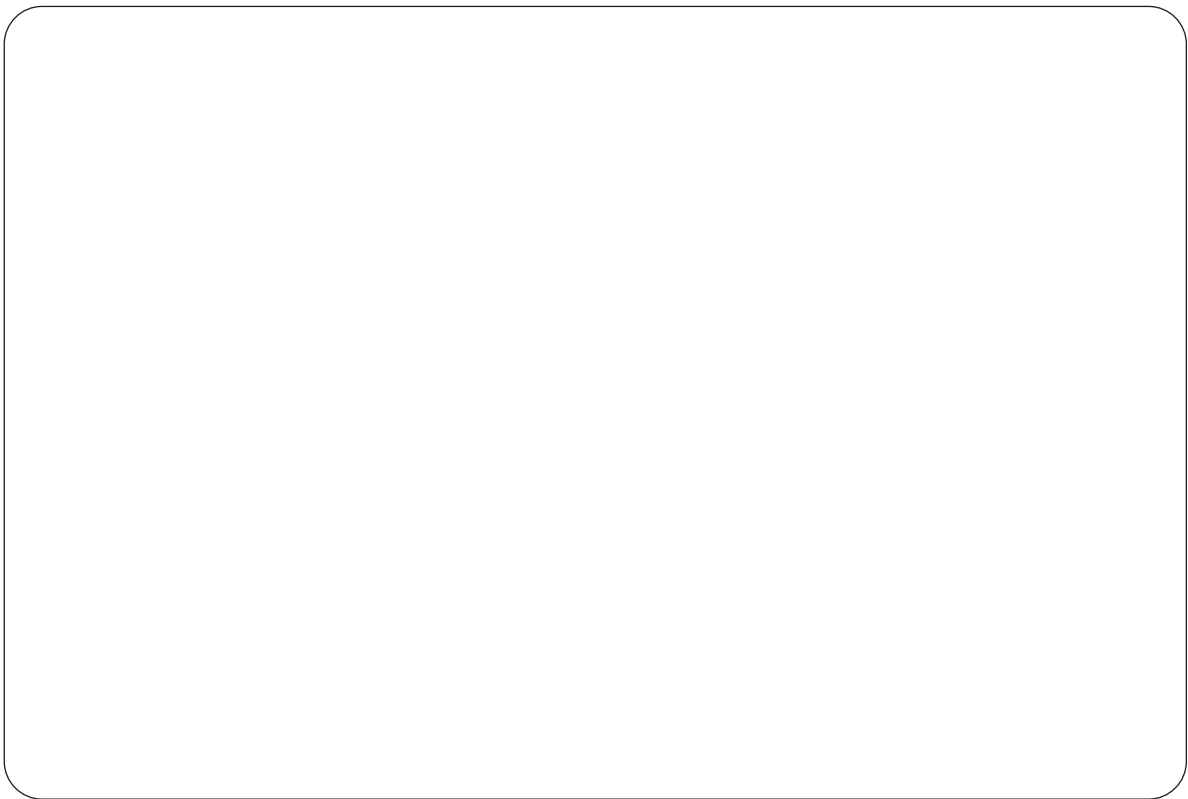

Product serial number

