

CE REV 003A

Quick®

High Quality Nautical Equipment

DV5 DAVE SERIES

DV5 1700 DC

DV5 2000 DC

DV5 2300 DC

DV5 3000 DC

DV5 3000 AC

DV5 HYDRO

CIMA E CATENA SU UN UNICO BARBOTIN
ROPE AND CHAIN ON A SINGLE GYPSY

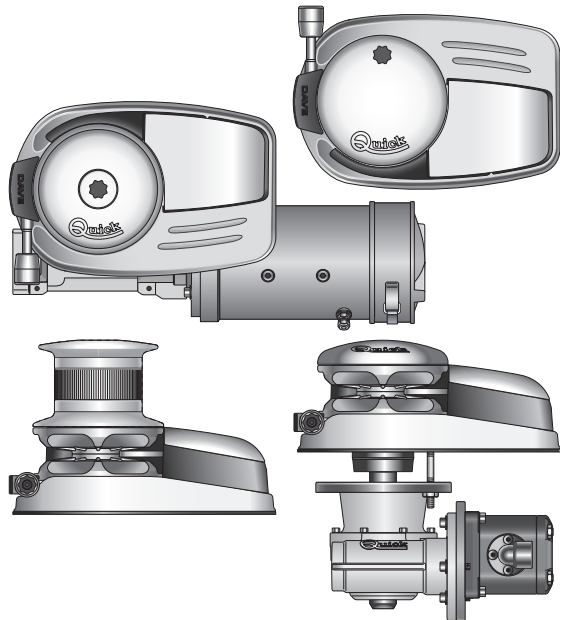

IT Manuale di installazione ed uso
EN Manual of installation and use

SALPA ANCORA VERTICALI
VERTICAL WINDLASSES

Quick®
Nautical Equipment



IT INDICE

Pag.	4	Caratteristiche tecniche
Pag.	5	Installazione
Pag.	6	Schema di collegamento 1700 / 2000 / 2300W
Pag.	7	Schema di collegamento 3000W
Pag.	8	Schema di collegamento trifase 3000W 230V
Pag.	9	Schema di collegamento trifase 3000W 400V
Pag.	10	Avvertenze importanti / Uso
Pag.	11/13	Manutenzione
Pag.	14/15	Ricambi
Pag.	16	Salpa ancora idraulico: caratteristiche tecniche - installazione
Pag.	17	Salpa ancora idraulico: schema di collegamento
Pag.	32/33	Disegni dimensioni

EN INDEX

Pag.	18	Technical data
Pag.	19	Installation
Pag.	20	Connection diagram 1700 / 2000 / 2300W
Pag.	21	Connection diagram 3000W
Pag.	22	Three-phase connection diagram 3000W 230V
Pag.	23	Three-phase connection diagram 3000W 400V
Pag.	24	Warning / Usage
Pag.	25/27	Maintenance
Pag.	28/29	Spare parts
Pag.	30	Hydraulic windlass: technical data - installation
Pag.	31	Hydraulic windlass: connection diagram
Pag.	32/33	Dimension drawings



COME SI LEGGE IL MODELLO DEL SALPA ANCORA:

1° ESEMPIO:
DV1712DX

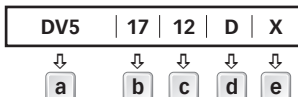

2° ESEMPIO:
DAVE3024Y

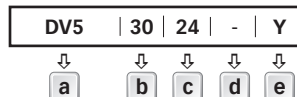

a

Nome della serie:
[DV5] = base ovale
in acciaio inox AISI 316

b

Potenza motore:
[17] = 1700 W
[20] = 2000 W
[23] = 2300 W
[30] = 3000 W

c

Tensione alimentazione motore:
[12] = 12 V
[24] = 24 V
[TR] = 230 V / 400 V

d

Campana:
[D] = con campana
[-] = senza campana

e

Passacatena:
[X] = passacatena destro
[Y] = passacatena sinistro

MODELLO	DV5 - / D				
POTENZA MOTORE	1700W		2000W	2300W	3000W
Tensione motore	12V	24V	24V	24V	
Tiro istantaneo massimo	1100 Kg (2425,1 lb)	1200 Kg (2645,5 lb)	1260 Kg (2777,8 lb)	2400 Kg (5291,1 lb)	3100 Kg (6834,3 lb)
Carico di lavoro massimo	470 Kg (1036,2 lb)	570 Kg (1256,6 lb)	750 Kg (1653,5 lb)	850 Kg (1873,9 lb)	1200 Kg (2645,5 lb)
Carico di lavoro	155 Kg (341,7 lb)	190 Kg (418,9 lb)	250 Kg (551,1 lb)	285 Kg (628,3 lb)	400 Kg (881,8 lb)
Assorbimento corrente al carico di lavoro ⁽¹⁾	175 A	100 A	115 A	120 A	145 A
Velocità massima di recupero ⁽²⁾	m/min 36,1 (118,4 ft/min)	38,3 (125,7 ft/min)	41,2 (135,2 ft/min)	41,2 (135,2 ft/min)	39,2 (128,6 ft/min)
Velocità di recupero al carico di lavoro ⁽²⁾	m/min 20,6 (67,6 ft/min)	20,8 (68,2 ft/min)	22,3 (73,2 ft/min)	23,3 (76,4 ft/min)	19,3 (63,3 ft/min)
Sezione minima cavi motore ⁽³⁾	50 mm ² (AWG0)	25 mm ² (AWG3)	35 mm ² (AWG2)	35 mm ² (AWG2)	50 mm ² (AWG0)
Interruttore di protezione ⁽⁴⁾	100 A	60 A	80 A	80 A	100 A
Spessore coperta ⁽⁵⁾	40 ÷ 80 mm (1" 9/16" ÷ 3" 5/32)				
Peso - modello senza campana	33,6 kg (74,1 lb)		39,3 kg (86,6 lb)	51,0 kg (112,4 lb)	61,3 kg (135,1 lb)
Peso - modello con campana	37,0 kg (81,6 lb)		42,7 Kg (94,1 lb)	54,4 Kg (119,9 lb)	64,7 Kg (142,6 lb)

MODELLO	DV5 - / D	
POTENZA MOTORE	3000W TR	
Tensione motore	230/400 V	
Tiro istantaneo massimo	2800 Kg	6172,9 lb
Carico di lavoro massimo	930 Kg	2050,3 lb
Velocità massima di recupero ⁽²⁾	15,4 m/nm	50,5 ft/min

(1) Dopo un primo periodo d'uso.

(2) Misure effettuate con barbotin per catena da 12/13 mm.

(3) Valore minimo consigliato per una lunghezza totale L<20m. Calcolare la sezione in funzione della lunghezza del collegamento.

(4) Con interruttore specifico per correnti continue (DC) e ritardato (magneto-termico o magneto-idraulico).

(5) Su richiesta possono essere forniti alberi e prigionieri per spessori di coperta maggiori.

BARBOTIN	10 mm - 3/8"				12/13 mm			14 mm		
	10 mm	10 mm	3/8"	3/8"	13 mm	12 mm	7/16"	14 mm	14 mm	1/2"
Catena supportata	DIN 766	ISO	G4	BBB	DIN 766	ISO	G4	DIN 766	ISO	G4
Cima supportata (*)	3/4" (19 mm)				3/4" (19 mm)			3/4" (19 mm)		

(*) I valori indicati in tabella si riferiscono ad una combinazione cima e catena secondo il sistema Quick®, non garantiamo il corretto funzionamento con altri tipi di anchor-rod.

Dimensioni dei modelli a pagina 32/33

Quick® si riserva il diritto di apportare modifiche alle caratteristiche tecniche dell'apparecchio e al contenuto di questo manuale senza alcun preavviso. In caso di discordanze o eventuali errori tra il testo tradotto e quello originario in italiano, fare riferimento al testo italiano.



PRIMA DI UTILIZZARE IL SALPA ANCORA LEGGERE ATTENTAMENTE IL PRESENTE MANUALE D'USO. IN CASO DI DUBBI CONSULTARE IL RIVENDITORE QUICK®.



ATTENZIONE: i salpa ancora Quick® sono stati progettati e realizzati per salpare l'ancora.

- Non utilizzare questi apparecchi per altri tipi di operazioni. • Quick® non si assume alcuna responsabilità per i danni diretti o indiretti causati da un uso improprio dell'apparecchio. • Il salpa ancora non è progettato per sostenere carichi generati in particolari condizioni atmosferiche (burrasca). • Disattivare sempre il salpa ancora quando non è in uso. • Accertarsi che non vi siano bagnanti nelle vicinanze prima di calare l'ancora. • La giunzione tra la cima e la catena deve avere dimensioni ridotte per poter scorrere agevolmente dentro la sagoma del barbotin. Per qualsiasi problema o richiesta contattare l'assistenza Quick®. • Per maggiore sicurezza, nel caso in cui uno si danneggi suggeriamo di installare almeno due comandi per l'azionamento del salpa ancora. • Consigliamo l'uso dell'interruttore magneto-idraulico Quick® come sicurezza per il motore. • Bloccare la catena con un fermo prima di partire per la navigazione.
- La scatola teleruttori o teleinvertitori deve essere installata in un luogo protetto da possibili entrate d'acqua.
- Dopo aver completato l'ancoraggio, fissare la catena o cima a punti fissi quali chian stopper o bitta.
- Per prevenire rilasci non voluti l'ancora deve essere fissata, il salpa ancora non deve essere usato come unica presa di forza.
- Isolare il salpa ancora dall'impianto elettrico durante la navigazione (disinserire l'interruttore di protezione del motore) e bloccare la catena ad un punto fisso dell'imbarcazione.

LA CONFEZIONE CONTIENE: salpa ancora (top + motoriduttore) - cassetta teleruttori (DV 1700/2000/2300W) / cassetta teleinvertitori (DV 3000W) - dima di foratura - leva - viterie (per l'assemblaggio) - manuale di istruzioni - condizioni di garanzia.

ATTREZZI NECESSARI PER L'INSTALLAZIONE: trapano con punta: Ø 12 mm (15/32"); a tazza Ø 90 mm (3"1/2); chiave esagonale: 17 mm.

ACCESSORI QUICK® CONSIGLIATI: deviatore da pannello (mod. 800) - Pulsantiera stagna (mod. HRC 1002) - Pulsante a piede (mod. 900) - Interruttore magneto-idraulico - Conta catena per l'ancoraggio (mod. CHC 1102M e CHC 1202M) - Sistema di comando via radio RRC (mod. R02, P02, H02).

REQUISITI PER L'INSTALLAZIONE: il salpa ancora va posizionato allineando il barbotin con il puntale di prua. Verificare che le superfici superiore e inferiore della coperta siano più parallele possibili; se ciò non dovesse accadere compensare opportunamente la differenza (la mancanza di parallelismo potrebbe causare perdite di potenza del motore). Lo spessore di coperta dovrà essere compreso fra i valori indicati in tabella. Se si avessero spessori differenti è necessario consultare il rivenditore Quick®. Non devono esistere ostacoli sotto coperta per il passaggio di cavi, cima e catena, la poca profondità del gavone potrebbe provocare inceppamenti.

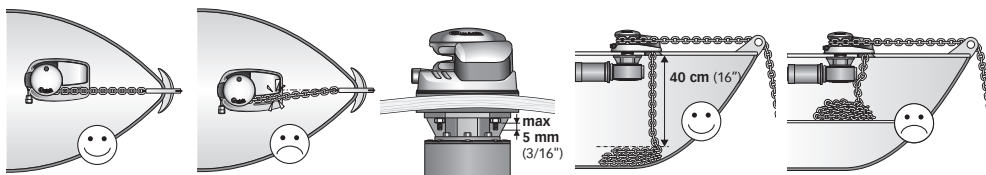

PROCEDURA DI MONTAGGIO: stabilita la posizione ideale praticare i fori utilizzando la dima di foratura fornita a corredo. Rimuovere il materiale in eccesso dal foro di passaggio della catena/cima, rifinirlo e lisciarlo con un prodotto specifico (vernice marittima, gel o resina epossidica) assicurando il libero passaggio della catena/cima. Posizionare la parte superiore e collegare a questa la parte inferiore infilando l'albero nel riduttore. Fissare il salpa ancora avvitando i dadi sui prigionieri di bloccaggio. Collegare i cavi di alimentazione provenienti dal salpa ancora al teleruttore.

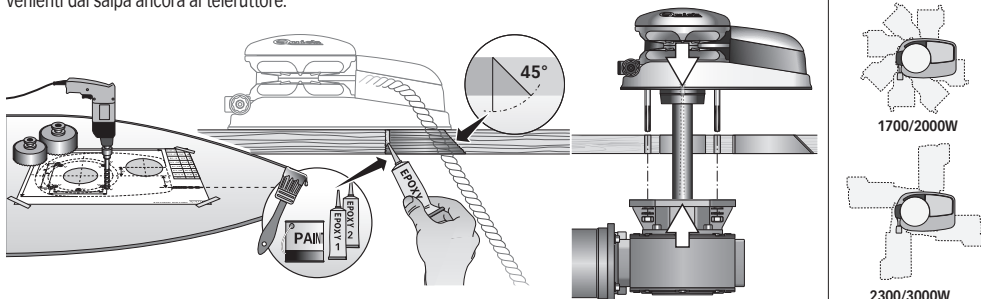

ATTENZIONE: prima di effettuare il collegamento accertarsi che non sia presente l'alimentazione su cavi.

Possibili installazioni dei motoriduttori



SISTEMA BASE DV5 1700-2000-2300W

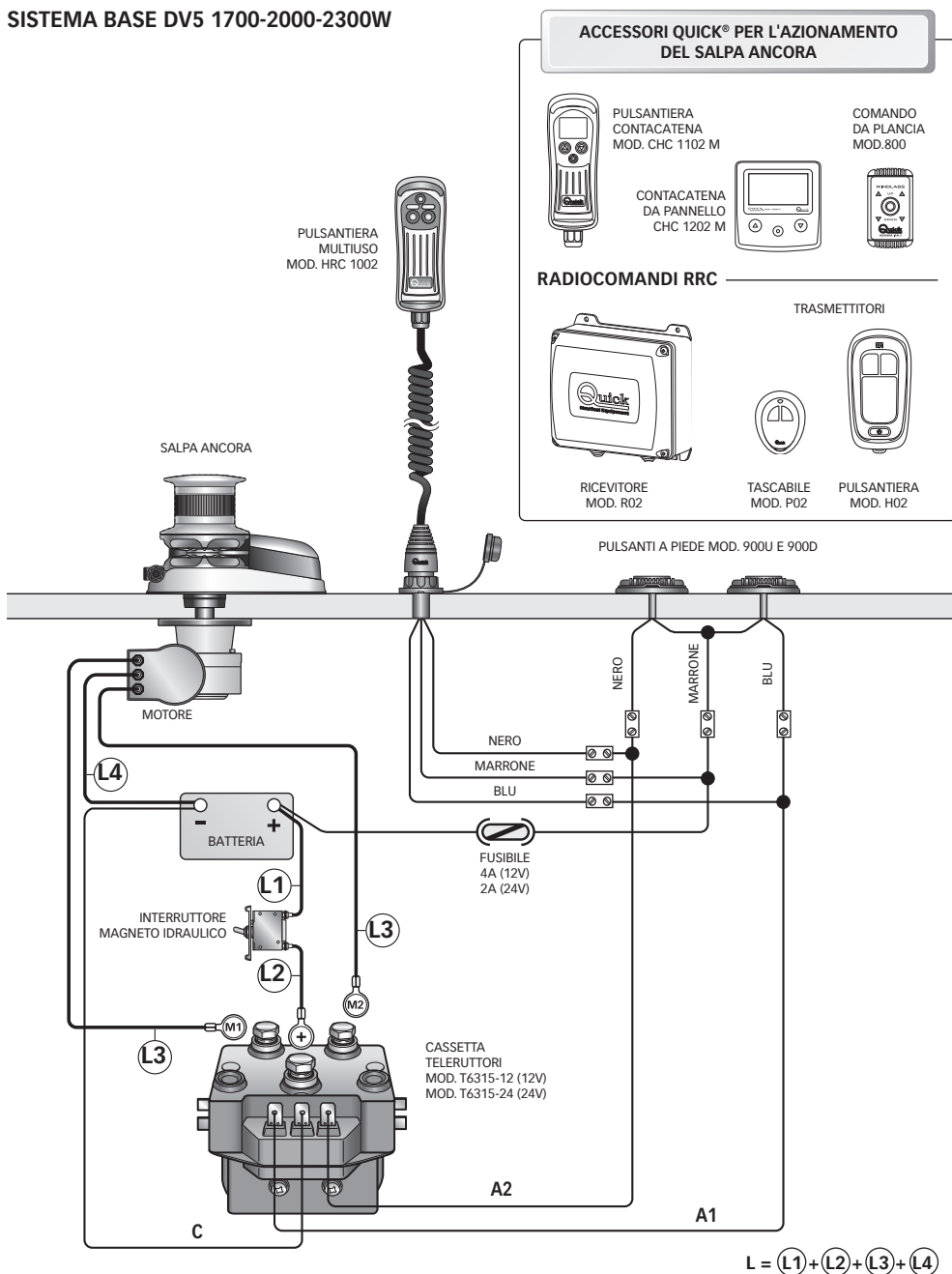



SISTEMA BASE DV5 3000W

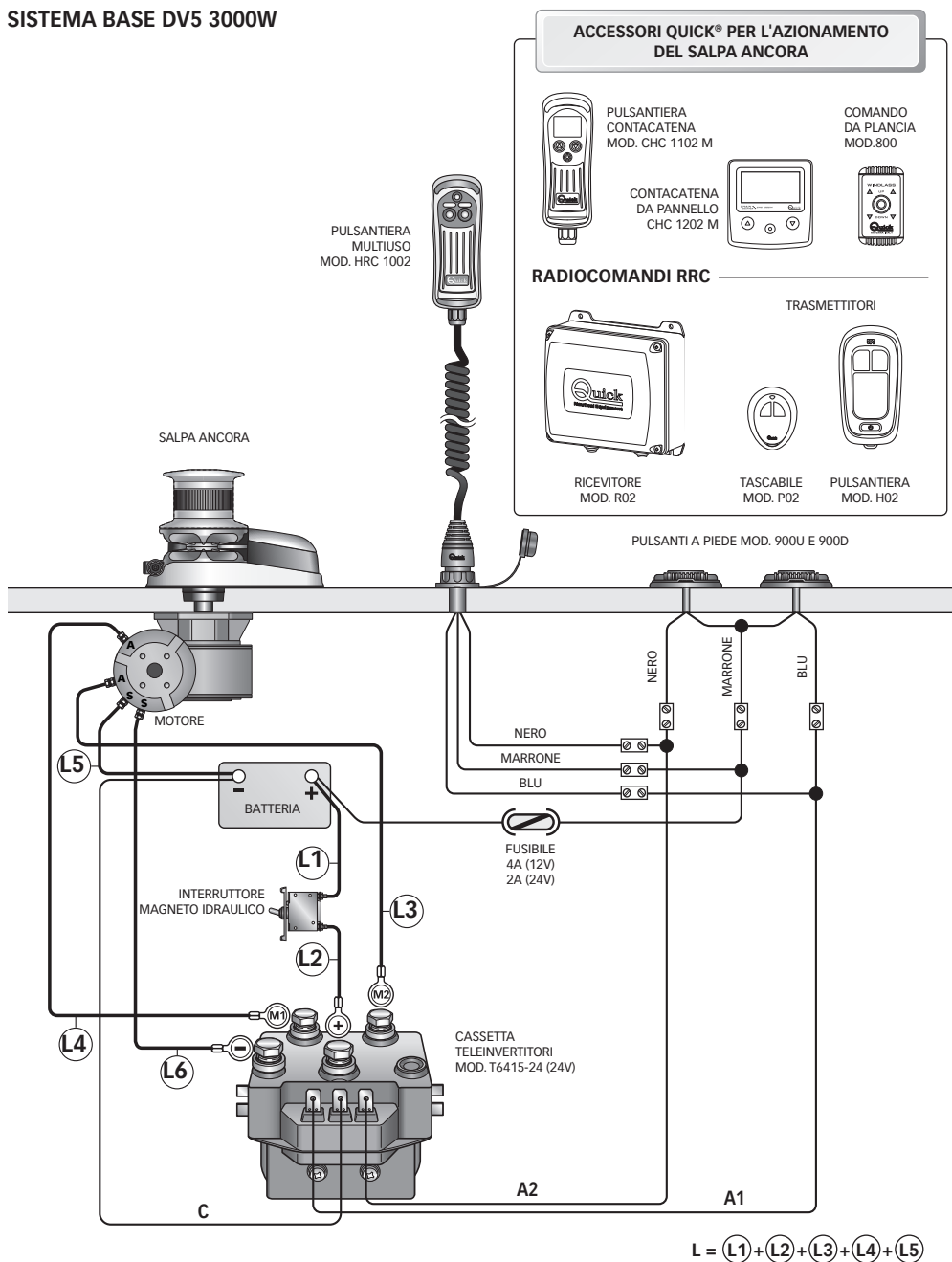



SISTEMA BASE DV5 3000W 230V

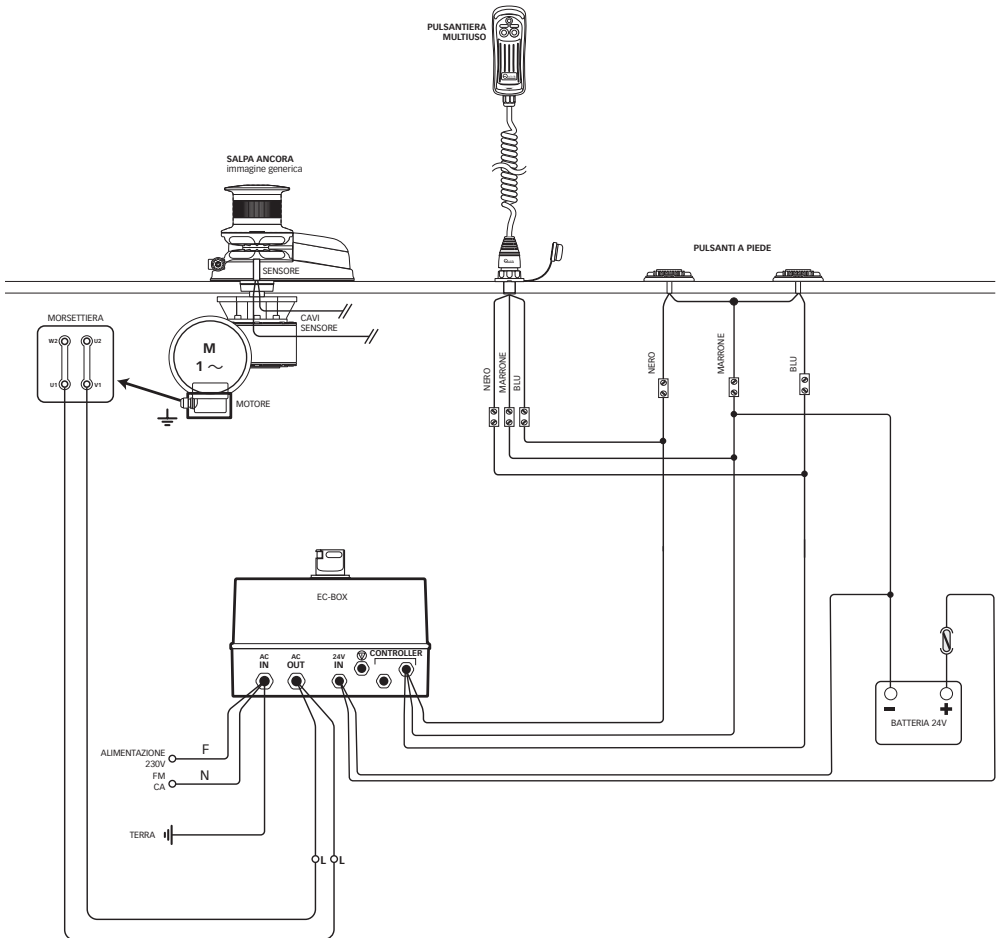



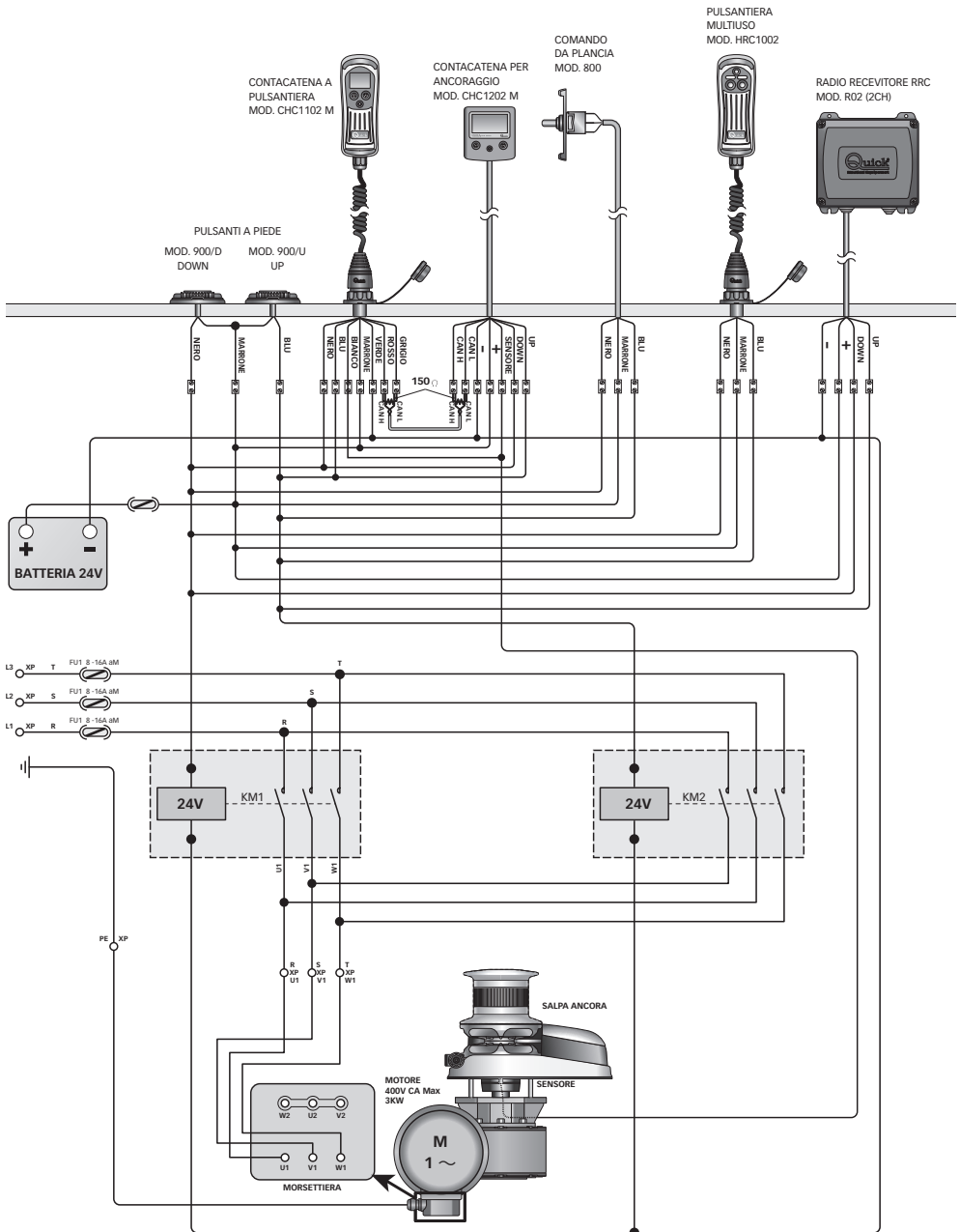

SISTEMA BASE DV5 3000W 400V





 **ATTENZIONE:** non avvicinare parti del corpo o oggetti alla zona in cui scorrono catena, cima e barbotin. Accertarsi che non sia presente l'alimentazione al motore elettrico quando si opera manualmente sul salpa ancora (anche quando si utilizza la leva per allentare la frizione); infatti persone dotate di comando a distanza del salpa ancora (pulsantiera remota o radiocomando) potrebbero accidentalmente attivarlo.

 **ATTENZIONE:** bloccare la catena con un fermo prima di partire per la navigazione.

 **ATTENZIONE:** non attivare elettricamente il salpa ancora con la leva inserita nella campana o nel coperchio del barbotin.

 **ATTENZIONE:** Quick® consiglia di utilizzare una protezione tipo fusibile/magnetotermico/magnetoidraulico di potenza adeguata a seconda del motore utilizzato per salvaguardare il motore da surriscaldamenti o corto-circuiti. L'interruttore può essere utilizzato per isolare il circuito di comando del salpa ancora evitando così azionamenti accidentali.

USO DELLA FRIZIONE

Il barbotin è reso solidale all'albero principale (27, 28, 29 o 30) dalla frizione (7 e 9).

La frizione si apre (stacco) utilizzando la leva (1) che inserita nella bussola (3) della campana (4) o nel coperchio barbotin (5), dovrà ruotare in senso antiorario. Ruotando in senso orario si provocherà la chiusura (attacco) della frizione.

PER SALPARE

Accendere il motore dell'imbarcazione. Assicurarsi che la frizione sia serrata e il freno allentato ed estrarre la leva. Premere il pulsante UP del comando a vostra disposizione. Se il salpa ancora si arresta senza che l'interruttore magneto-idraulico (o magnetotermico) sia scattato, attendere qualche secondo e riprovare (evitare una pressione continuata del pulsante). Se l'interruttore magneto-idraulico (o magnetotermico) è scattato, riattivare l'interruttore e attendere qualche minuto prima di riprendere a salpare. Se, dopo ripetuti tentativi, il salpa ancora continua a bloccarsi consigliamo di manovrare l'imbarcazione per disincagliare l'ancora. Controllare la salita degli ultimi metri di catena per evitare danni alla prua.

PER CALARE

La calata dell'ancora si può effettuare tramite comandi elettrici oppure manualmente. Per effettuare l'operazione manualmente occorre aprire la frizione e allentare il freno, lasciando libero il barbotin di girare sul proprio asse e trascinare la catena o la cima in acqua. Per frenare la caduta dell'ancora bisogna ruotare la leva in senso orario. Per calare l'ancora elettricamente occorre premere il pulsante DOWN del comando a vostra disposizione. In questo modo la calata è perfettamente controllabile e lo svolgimento della catena o della cima è regolare. Per evitare sollecitazioni sul salpa ancora, una volta ancorati, bloccare la catena con un fermo oppure fissarla ad un punto saldo con una cima.

USO DELLA CAMPANA

 **ATTENZIONE:** Prima di eseguire operazioni di tonneggio, accertarsi che l'ancora e relativa cima o catena siano fissate saldamente ad una bitta o ad altro punto resistente dell'imbarcazione.

Per l'uso indipendente della campana (4), agire sul freno (15) per bloccare il barbotin (8). Con la leva (1) aprire la frizione (almeno due giri della bussola in senso antiorario). Rimuovere la leva dalla bussola (3), avvolgere la cima sulla campana in senso antiorario (2 giri). Attivare il comando DOWN del salpa ancora mantenendo in tensione la cima durante il recupero. Variando questa tensione in fase di recupero è possibile modificare la velocità di avvolgimento della cima.

 **ATTENZIONE:** durante il recupero, mantenere un'adeguata distanza di sicurezza tra mani e campana salpa ancora.

Terminata la procedura di recupero serrare la frizione stringendo la bussola del barbotin in senso orario e assicurare la cima ad una bitta o ad altro punto resistente dell'imbarcazione.

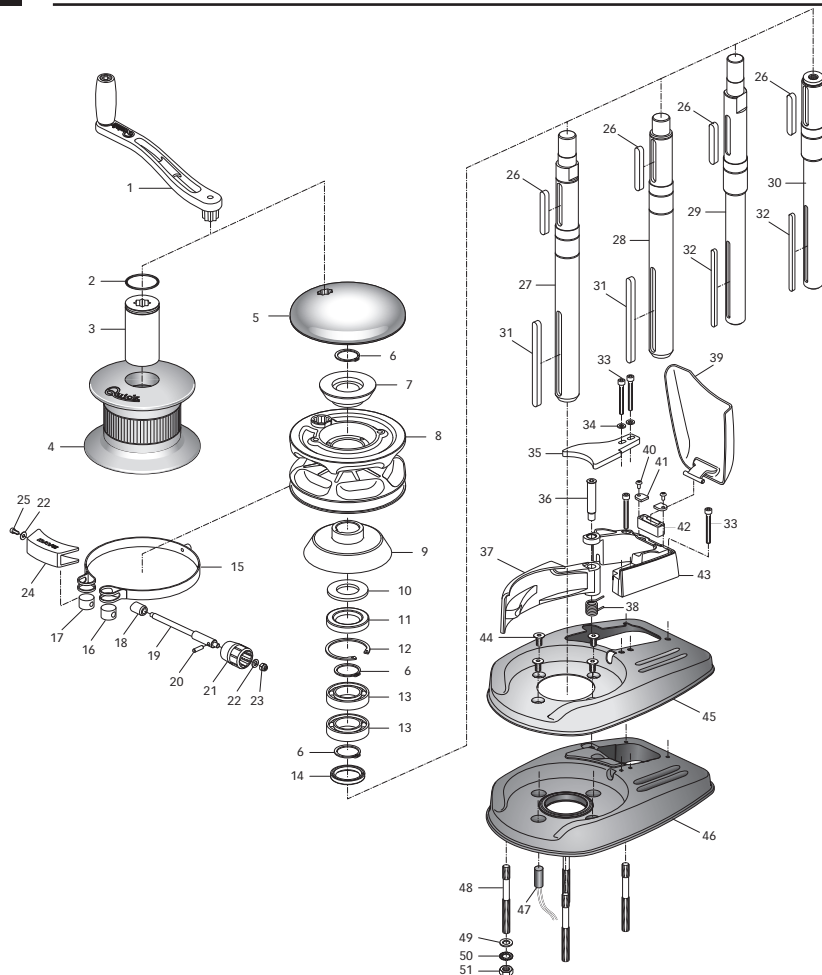

ATTENZIONE: accertarsi che non sia presente l'alimentazione al motore elettrico quando si opera manualmente sul salpa ancora; rimuovere con cura la catena dal barbotin o la cima dalla campana.

I salpa ancora Quick® sono costituiti da materiali resistenti all'ambiente marino: è indispensabile, in ogni caso, rimuovere periodicamente i depositi di sale che si formano sulle superfici esterne per evitare corrosioni e di conseguenza danni all'apparecchio.

Lavare accuratamente con acqua dolce le superfici e le parti in cui il sale può depositarsi.

Smontare una volta all'anno il barbotin e la campana attenendosi alla seguente sequenza:

VERSIONE CON CAMPANA

Con la leva (1) svitare la bussola (3); estrarre la campana (4) e il cono frizione superiore (7); svitare le viti di fissaggio (33) dello stacca catena (35) e rimuoverlo; estrarre il barbotin (8).

VERSIONE SENZA CAMPANA

Con la leva (1) svitare il coperchio barbotin (5) e il cono frizione superiore (7); svitare le viti di fissaggio (33) dello stacca catena (35) e rimuoverlo; estrarre il barbotin (8).

Pulire ogni parte smontata affinché non si verifichino attacchi di corrosione e ingrassare (con grasso marino) il filetto dell'albero (27, 28, 29 o 30) e il barbotin (8) dove appoggiano i coni frizione (7 e 9).

Rimuovere eventuali depositi di ossido sui morsetti della cassetta teleruttori/teleinvertitori; cospargerli di grasso.

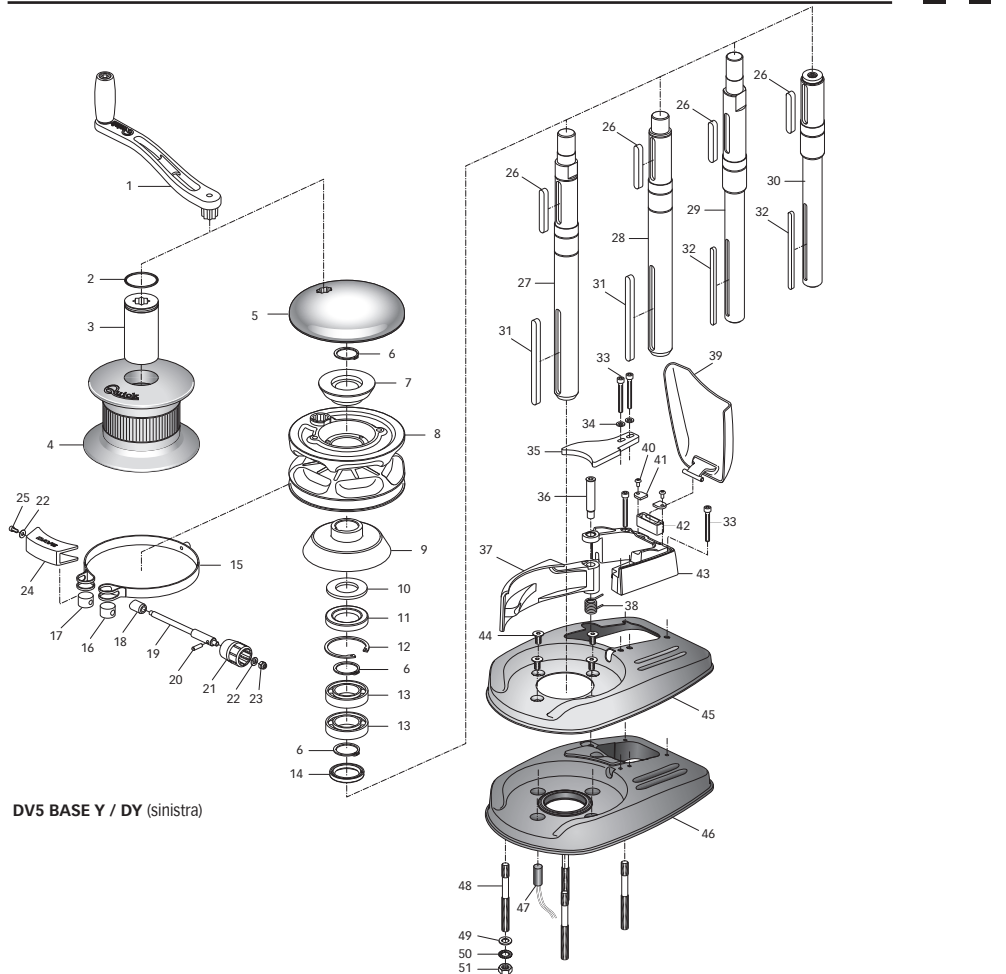

DV5 BASE Y / DY (sinistra)

POS. DENOMINAZIONE

1	LEVA SALPA PIEGATA	19	ALBERO FRENO FASCIA "DV" 4000W	38A	MOLLA TENDICIMA SALPA 3000W "DV" X
2	O-RING BUSSOLA	20	SPINA	38B	MOLLA TENDICIMA SALPA 3000W "DV" Y
3	BUSSOLA CAMPANA	21	POMELLO FRENO FASCIA SERIE "DV"	39A	COPERCHIO GUIDA CATENA "DV" X
4	CAMPANA SALPA 2000W	22	RONDELLA	39B	COPERCHIO GUIDA CATENA "DV" Y
5	COPERCHIO BARBOTIN	23	DADO AUTOBLOCCANTE	40	VITE
6	ANELLO ELASTICO ESTERNO	24	CARTER FRENO FASCIA "DV"	41	INSERTO GUIDA CATENA "DV" INOX
7	CONO FRIZIONE SALPA 3000W SUP.	25	VITE	42	INSERTO PLAST CADUTA CATENA 3000W "DV"
8A	BARBOTIN 3000W 10 MM-3/8" COMPL.	26	CHIAVETTA	43A	SUPPORTO GUIDA CATENA "DV" X
8B	BARBOTIN 3000W 12-13 MM COMPL.	27	ALBERO SERIE "DV" 3000W D	43B	SUPPORTO GUIDA CATENA "DV" Y
8C	BARBOTIN 3000W 14MM COMPL.	28	ALBERO SERIE "DV" 3000W	44	VITE
9	CONO FRIZIONE SALPA 3000W INF.	29	ALBERO SERIE "DV" 1700W D	45A	COVER BASE "DV" INOX X
10	RONDELLA DI RINFORZO 3000W	30	ALBERO SERIE "DV" 1700W	45B	COVER BASE "DV" INOX Y
11	PARAOILIO	31	CHIAVETTA	46A	BASE SALPA SERIE "DV" X
12	ANELLO ELASTICO INTERNO	32	CHIAVETTA	46B	BASE SALPA SERIE "DV" Y
13	CUSCINETTO	33	VITE	47	SENSORE REED ASSEMBLATO
14	PARAOILIO	34	RONDELLA	48	PRIGIONIERO
15	FRENO FASCIA 4000 W "DV"	35	STACCA CATENA 4000W "DV"	49	RONDELLA
16	PERNO OTTONE FRENO FASCIA 3000W	36	PERNO TENDICIMA 3000W "DV"	50	GROWER
17	PERNO OTTONE FRENO FASCIA FORO	37A	LEVA TENDICIMA "DV" X	51	DADO
18	INSERTO ALBERO FRENO A FASCIA "DV"	37B	LEVA TENDICIMA "DV" Y		

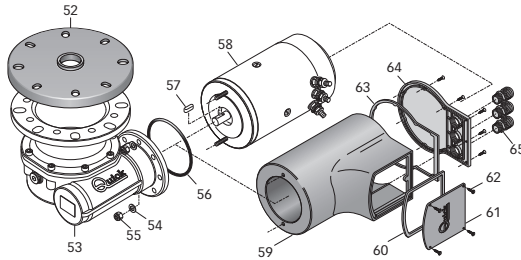
**MOTORIDUTTORE 1700W**

POS.	DENOMINAZIONE
52	GUARNIZIONE FLANGIA RIDUT. TOP TG70
53	RIDUTTORE - 1700W - SERIE QUICK
54	RONDELLA
55	DADO AUTOBLOCCANTE
56	O-RING RIDUTTORE 1700W
57	CHIAVETTA
58 A	MOTORE 1700W 12V
58 B	MOTORE 1700W 24V
59	CARTER MOTORE 1700W
60	GUARNIZIONE MORSETTIERA
61	COPERCHIO MORSETTIERA
62	VITE
63	GUARNIZIONE FONDO
64	COPERCHIO FONDO
65	PASSACAVI
66	RIDUTTORE 2000W
67	RONDELLA
68	VITE
69	O-RING 2000W
70	CHIAVETTA
71	MOTORE 2000W - 24V
72	CARTER MOTORE 2000W
73	O-RING COPERTURA MOTORE
74	COPERCHIO FONDO
75	GUARNIZIONE MORSETTIERA INF.
76	GUARNIZIONE MORSETTIERA SUP.
77	COPERCHIO MORSETTIERA SUP.
78	VITE AUTOFILETTANTE
79	VITE AUTOFILETTANTE
80	RIDUTTORE 3000W - 24V
81	GUARNIZIONE MOTORIDUTTORE 3000W
82	ADATTATORE MOTORE 2300W
83	CHIAVETTA ADATTATORE
84	MOTORE 2300W 24V
85	MOTORE 3000W 24V
86	CHIAVETTA
87	MOTORE 4000W AC 230/400

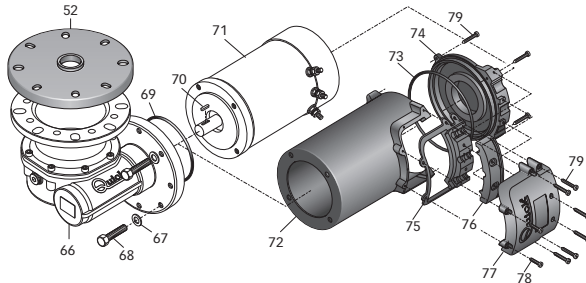
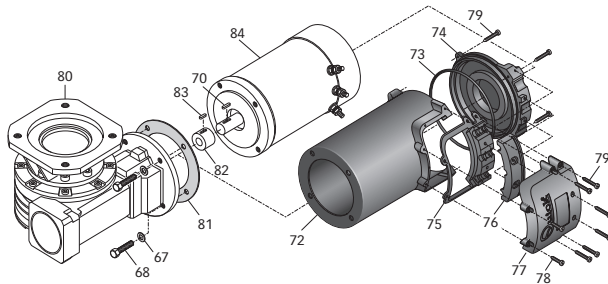
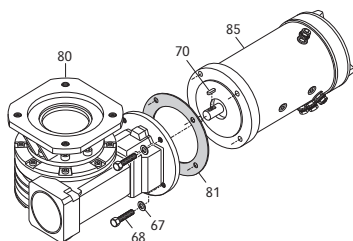
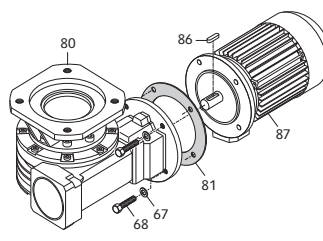
MOTORIDUTTORE 2000W**MOTORIDUTTORE 2300W****MOTORIDUTTORE 3000W****MOTORIDUTTORE 3000 TR**

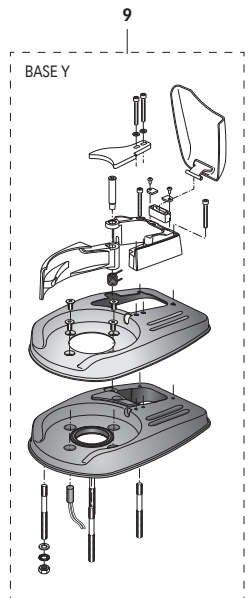
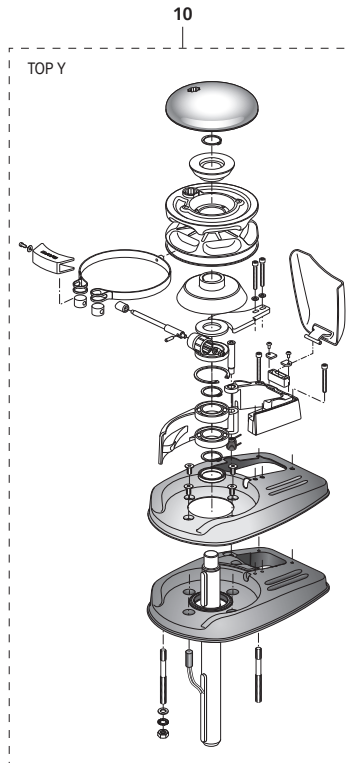
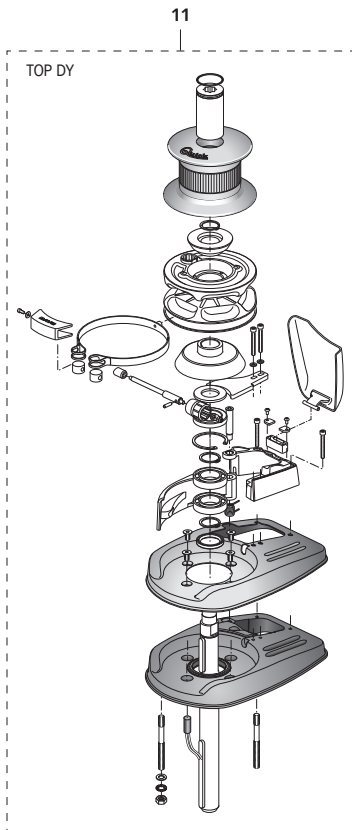
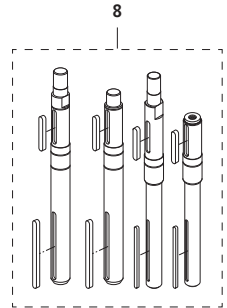
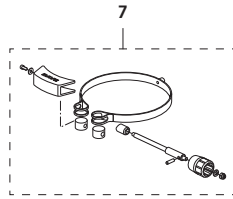
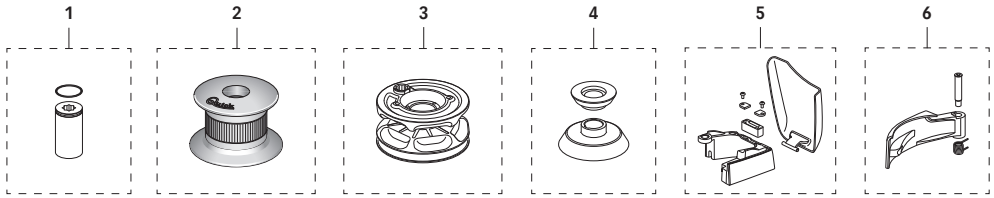



1	OSP BUSSOLA CAMPANA SERIE DV5	FVSSGMSDCPAG300	10A	OSP TOP DV5 17/2000W X	10MM	FVSSTDVX17010A0
2	OSP CAMPANA SALPA 3000W HR5/DV5/RG5/TB5	FVSSMSE30AG0A00	10B	OSP TOP DV5 17/2000W X	12-13MM	FVSSTDVX17012A0
3A	OSP BARBOTIN 3000W 10MM-3/8" DV5	FVSSB3010382A00	10C	OSP TOP DV5 17/2000W X	14MM	FVSSTDVX17014A0
3B	OSP BARBOTIN 3000W 12MM-13MM DV5	FVSSB3012132A00	10D	OSP TOP DV5 17/2000W Y	10MM	FVSSTDVY17010A0
3C	OSP BARBOTIN 3000W 14MM DV5	FVSSB3014002A00	10E	OSP TOP DV5 17/2000W Y	12-13MM	FVSSTDVY17012A0
4	OSP KIT CONI FRIZIONE 3000W DV5/RG5	FVSSCF30DV00A00	10F	OSP TOP DV5 17/2000W Y	14MM	FVSSTDVY17014A0
5A	OSP KIT COPERCHIO GUIDA CATENA DV5 X	FVSSPCSDVX0A00	11A	OSP TOP DV5 17/2000W DX	10MM	FVSSTDVX17D10A0
5B	OSP KIT COPERCHIO GUIDA CATENA DV5 Y	FVSSPCSDVY0A00	11B	OSP TOP DV5 17/2000W DX	12-13MM	FVSSTDVX17D12A0
6A	OSP KIT TENDICIMA DV5 X	FVSSCTDVX000A00	11C	OSP TOP DV5 17/2000W DX	14MM	FVSSTDVX17D14A0
6B	OSP KIT TENDICIMA DV5 Y	FVSSCTDVY000A00	11D	OSP TOP DV5 17/2000W DY	10MM	FVSSTDVY17D10A0
7	OSP KIT FRENO FASCIA INOX DV5	FVSSFRDVX000A00	11E	OSP TOP DV5 17/2000W DY	12-13MM	FVSSTDVY17D12A0
8A	OSP KIT ALBERO DV5 1700	FVSSADV17000A00	11F	OSP TOP DV5 17/2000W DY	14MM	FVSSTDVY17D14A0
8B	OSP KIT ALBERO DV5 1700 D	FVSSADV1700DA00	10A	OSP TOP DV5 3000W X	10MM	FVSSTDVX30010A0
8C	OSP KIT ALBERO DV5 3000	FVSSADV30000A00	10B	OSP TOP DV5 3000W X	12-13MM	FVSSTDVX30012A0
8D	OSP KIT ALBERO DV5 3000 D	FVSSADV3000DA00	10C	OSP TOP DV5 3000W X	14MM	FVSSTDVX30014A0
9A	OSP BASE SALPA SERIE DV5 X	FVSSBDV5X000A00	10D	OSP TOP DV5 3000W Y	10MM	FVSSTDVY30010A0
9B	OSP BASE SALPA SERIE DV5 Y	FVSSBDV5Y000A00	10E	OSP TOP DV5 3000W Y	12-13MM	FVSSTDVY30012A0
			10F	OSP TOP DV5 3000W Y	14MM	FVSSTDVY30014A0
			11A	OSP TOP DV5 3000W DX	10MM	FVSSTDVX30D10A0
			11B	OSP TOP DV5 3000W DX	12-13MM	FVSSTDVX30D12A0
			11C	OSP TOP DV5 3000W DX	14MM	FVSSTDVX30D14A0
			11D	OSP TOP DV5 3000W DY	10MM	FVSSTDVY30D10A0
			11E	OSP TOP DV5 3000W DY	12-13MM	FVSSTDVY30D12A0
			11F	OSP TOP DV5 3000W DY	14MM	FVSSTDVY30D14A0

12A	OSP RIDUTTORE 2300W SALPA DV5	FVSSMR230000A00
12B	OSP RIDUTTORE 3000W SALPA DV5/TB6	FVSSMR300000A00
13A	OSP MOTORIDUTTORE 2300W 24V DV5	FVSSR2324000A00
13B	OSP MOTORIDUTTORE 3000W 230/400V DV5	FVSSR30TRL00A00
13C	OSP MOTORIDUTTORE 3000W 24V DV5	FVSSR3024000A00
14A	OSP MOTORE 2300W SALPA DV5	FVSSMR230000A00
14B	OSP MOTORE 3000W SALPA DV5/TB6	FVSSMR300000A00

13

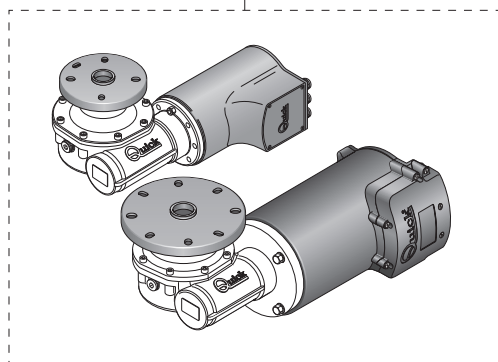

12

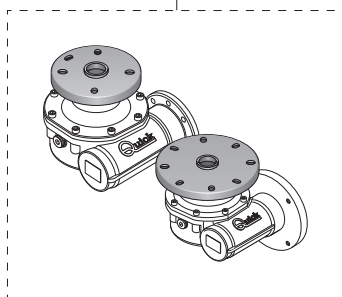

14

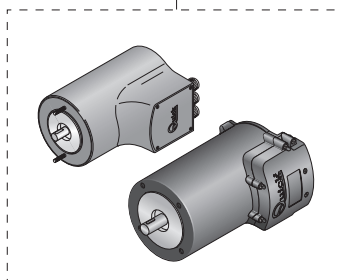



MODELLO IDRAULICO	DV5 HYDRO - / D	
Tipologia motore	Reversibile ad ingranaggi	
Cilindrata	9,6 cc	0,59 in ³
Capacità di sollevamento	• 100 bar = 600 kg • 200 bar = 1700 kg	• 1450.4 psi = 1433 lb • 2900 psi = 3748 lb
Velocità di recupero al carico di lavoro (1)	40 lt /min = 23 mt/min	9,1 USG/min = 76 ft/min
Spessore coperta (2)	40 ÷ 80 mm	1" 9/16 ÷ 3" 5/32 inch
Peso senza campana	31,8 kg	70,1 lb
Peso con campana	37 kg	81,6 lb
VALORI DI REGOLAZIONE (consigliati da Quick)		
Portata	40 lt/min	9,1 USG/min
Pressione massima	200 bar	2900 psi

(1) Misure effettuate con barbotin per catena da 12 mm.

(2) Su richiesta possono essere forniti alberi e prigionieri per spessori di coperta maggiori.

Dimensioni del modello a pagina 33

LA CONFEZIONE CONTIENE: salpa ancora idraulico (top + motoriduttore) - dima di foratura - leva - viterie (per l'assemblaggio) - manuale di istruzioni - condizioni di garanzia.

ATTREZZI NECESSARI PER L'INSTALLAZIONE: trapano con punta: Ø 12 mm (15/32"); a tazza Ø 90 mm (3"1/2); chiave esagonale: 17 mm.

ACCESSORI QUICK® CONSIGLIATI: deviatore da pannello (mod. 800) - Pulsantiera stagna (mod. HRC 1002) - Pulsante a piede (mod. 900) - Interruttore magneto-idraulico - Conta catena per l'ancoraggio (mod. CHC 1102M e CHC 1202M) - Sistema di comando via radio RRC (mod. R02, P02, H02).

PROCEDURA DI MONTAGGIO

Posizionare la parte superiore e collegare a questa la parte inferiore, infilando l'albero nel riduttore.

Fissare il salpa ancora avvitando i dadi sui prigionieri di bloccaggio. Collegare i tubi provenienti dalla valvola distributrice alle due flangette del motore idraulico (vedi schema di collegamento a pag.17).

ESEMPIO INSTALLAZIONE
TOP SENZA CAMPANA

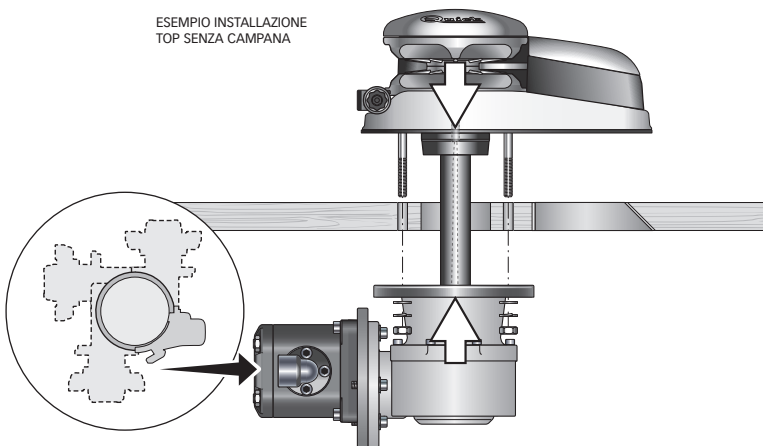

Quick® si riserva il diritto di apportare modifiche alle caratteristiche tecniche dell'apparecchio e al contenuto di questo manuale senza alcun preavviso. In caso di discordanze o eventuali errori tra il testo tradotto e quello originario in italiano, fare riferimento al testo italiano o inglese.



SISTEMA BASE DV5 IDRAULICO

SCHEMA DI COLLEGAMENTO

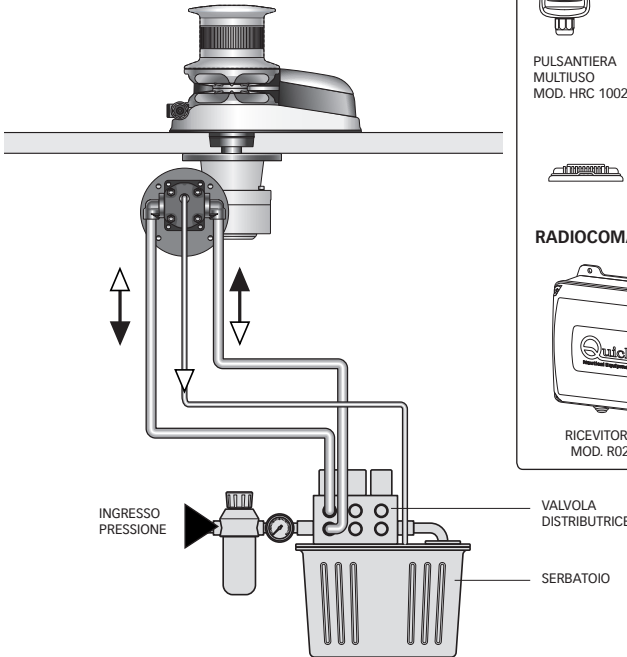

ACCESSORI QUICK® PER L'AZIONAMENTO DEL SALPA ANCORA IDRAULICO



PULSANTIERA MULTIUSO MOD. HRC 1002



PULSANTIERA CONTACATENA MOD. CHC 1102 M



CONTACATENA DA PANNELLO CHC 1202 M



COMANDO DA PLANCIA MOD. 800



PULSANTI A PIEDE MOD. 900U E 900D

RADIOCOMANDI RRC



RICEVITORE MOD. R02

TRASMETTITORI



TASCABILE MOD. P02



PULSANTIERA MOD. H02

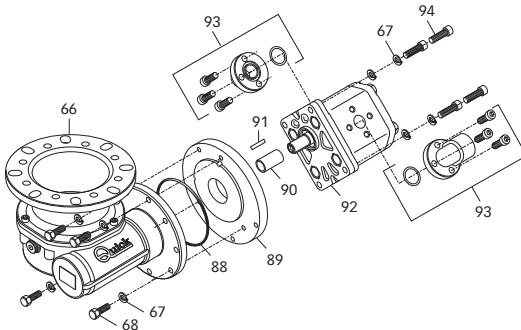

- | N°. | DENOMINAZIONE |
|-----|---|
| 66 | RIDUTTORE - 2000W - SERIE QUICK |
| 67 | VITE |
| 68 | GROWER |
| 87 | O-RING |
| 89 | FLANGIA |
| 90 | ADATTATORE TG70 |
| 91 | CHIAVETTA |
| 92 | MOTORE AD INGRANAGGI 17,9CC BIDIREZIONALE |
| 93 | FLANGETTA 90° G3/4 FEMMINA |
| 94 | VITE |



HOW TO IDENTIFY THE WINDLASS THROUGH THE CODE:

1° EXAMPLE:
DV1712DX

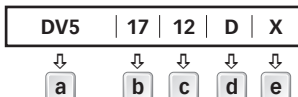

2° EXAMPLE:
DAVE3024Y

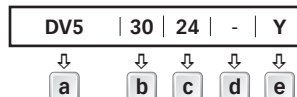

a

Name of the line:
[DV5] = base ovale
in acciaio inox AISI 316

b

Motor output:
[17] = 1700 W
[20] = 2000 W
[23] = 2300 W
[30] = 3000 W

c

Motor supply voltage:
[12] = 12 V
[24] = 24 V
[TR] = 230 V / 400 V

d

Drum:
[D] = con campana
[-] = senza campana

e

Chain pipe:
[X] = right chain pipe
[Y] = left chain pipe

MODEL	DV5 - / D				
MOTOR OUTPUT	1700W		2000W	2300W	3000W
Motor supply voltage	12V	24V	24V	24V	
Maximum pull	1100 Kg (2425,1 lb)	1200 Kg (2645,5 lb)	1260 Kg (2777,8 lb)	2400 Kg (5291,1 lb)	3100 Kg (6834,3 lb)
Maximum working load	470 Kg (1036,2 lb)	570 Kg (1256,6 lb)	750 Kg (1653,5 lb)	850 Kg (1873,9 lb)	1200 Kg (2645,5 lb)
Working load	155 Kg (341,7 lb)	190 Kg (418,9 lb)	250 Kg (551,1 lb)	285 Kg (628,3 lb)	400 Kg (881,8 lb)
Current absorption @ working load ⁽¹⁾	175 A	100 A	115 A	120 A	145 A
Maximum chain speed ⁽²⁾	m/min 36,1 (118,4 ft/min)	38,3 (125,7 ft/min)	41,2 (135,2 ft/min)	41,2 (135,2 ft/min)	39,2 (128,6 ft/min)
Max. chain speed @ working load ⁽²⁾	m/min 20,6 (67,6 ft/min)	20,8 (68,2 ft/min)	22,3 (73,2 ft/min)	23,3 (76,4 ft/min)	19,3 (63,3 ft/min)
Sezione minima cavi motore ⁽³⁾	50 mm ² (AWG0)	25 mm ² (AWG3)	35 mm ² (AWG2)	35 mm ² (AWG2)	50 mm ² (AWG0)
Interruttore di protezione ⁽⁴⁾	100 A	60 A	80 A	80 A	100 A
Deck thickness ⁽⁵⁾	40 - 80 mm (1" 9/16" - 3" 5/32)				
Weight - model without drum	33,6 kg (74,1 lb)		39,3 kg (86,6 lb)	51,0 kg (112,4 lb)	61,3 kg (135,1 lb)
Weight - model with drum	37,0 kg (81,6 lb)		42,7 Kg (94,1 lb)	54,4 Kg (119,9 lb)	64,7 Kg (142,6 lb)

MODEL	DV5 - / D	
MOTOR OUTPUT	3000W TR	
Motor supply voltage	230/400 V	
Maximum pull	2800 Kg	6172,9 lb
Maximum working load	930 Kg	2050,3 lb
Maximum chain speed ⁽²⁾	15,4 m/nm	50,5 ft/min

(1) After an initial period of use.

(2) Measurements taken with a gypsy for a 12/13 mm chain.

(3) Minimum allowable value for a total length L<20m. Determine the cable size according to the length of the wiring.

(4) With circuit breaker designed for direct currents (DC) and delayed-action (thermal-magnetic or hydraulic-magnetic).

(5) On request, shafts and studs can be supplied for greater deck thicknesses.

GYPSIES	10 mm - 3/8"				12/13 mm			14 mm		
	10 mm	10 mm	3/8"	3/8"	13 mm	12 mm	7/16"	14 mm	14 mm	1/2"
Chain size	DIN 766	ISO	G4	BBB	DIN 766	ISO	G4	DIN 766	ISO	G4
Rope size (*)	3/4" (19 mm)				3/4" (19 mm)			3/4" (19 mm)		

(*) The values indicated in the table refer to a rope and chain combination manufactured with the Quick® system, do not guarantee the correct functioning with other types of anchor-rode.

Models' dimensions on page 32/33

Quick® reserves the right to introduce changes to the equipment and the contents of this manual without prior notice. In case of discordance or errors in translation between the translated version and the original text in the Italian language, reference will be made to the Italian or English text.



**BEFORE USING THE WINDLASS READ THESE INSTRUCTIONS CAREFULLY.
IF IN DOUBT, CONTACT YOUR NEAREST "QUICK®" DEALER.**

- ⚠ WARNING:** the Quick® windlasses are designed to weigh the anchor. • Do not use the equipment for other purposes.
- Quick® shall not be held responsible for damage to equipment and/or personal injury, caused by a faulty use of the equipment.
 - The windlass is not designed for the loads that might occur in extreme weather conditions (storms).
 - Always deactivate the windlass when not in use. • Check that there are no swimmers nearby before dropping anchor.
 - The splice between the rope and the chain must be tightly woven for the rope to slide easily into the gypsy shape. For any problem or request, feel free to contact Quick® Technical Service. • For improved safety we recommend installing at least two anchor windlass controls in case one is accidentally damaged. • We recommend the use of the Quick® hydraulic-magnetic switch as the motor safety switch. • Secure the chain with a further device before starting the navigation.
 - The contactor unit or reversing contactor unit must be installed in a point protected from accidental water contact.
 - After completing the anchorage, secure the chain or rope to fixed points such as chain stopper or bollard.
 - To prevent accidental releases, the anchor must be secured. The windlass shall not be used as the only securing device.
 - Isolate the windlass from the power system during navigation (switch the circuit breaker off) and lock the chain securing it to a fixed point of the boat.

THE PACKAGE CONTAINS: windlass (on deck unit + motorgearbox) - contactor unit (DV 1700/2000/2300W) / reversing contactor unit (DV 3000W) - base gasket - drill template - handle - bolts and screws (for assembly) - user's manual - conditions of warranty.

TOOLS REQUIRED FOR INSTALLATION: drill and drill bits: Ø 12 mm (15/32"); Ø 90 mm (3 1/2") hollow mill; hexagonal wrench: 17 mm.

"QUICK®" ACCESSORIES RECOMMENDED: anchoring RL control board (mod. 800) - Waterproof hand holds R/C (mod. HRC1002) - Foot switch (mod. 900) - Hydraulic-magnetic circuit breaker - Anchor chain counter (mod. CHC1102M and CHC1202M) - Radio control RRC (mod. R02, P02, H02).

INSTALLATION REQUIREMENTS: the windlass must be positioned with the gypsy aligned with the bow roller. Ensure that the upper and lower surfaces of the deck are as parallel as possible. If this is not the case, compensate the difference appropriately (a lack of parallelism could result in a loss of motor power). The deck thickness must be included among the figures listed in the table. In cases of other thicknesses it is necessary to consult a Quick® retailer. There must be no obstacles under deck to the passage of cables, rope and chain; lack of depth of the peak could cause jamming.

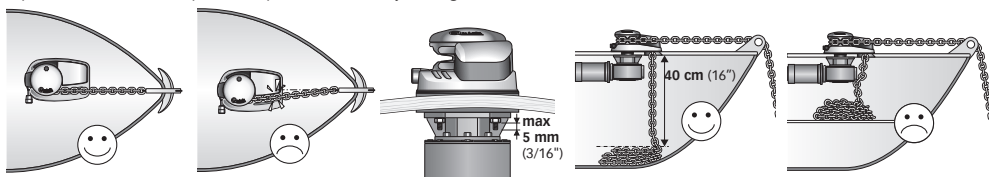

FITTING PROCEDURE: when the ideal position has been established, drill four holes using the drilling template provided. Remove excess material from the chain passage, refine and flatten with a specialized product (marine paint, gel coat or two pack epoxy) to assure free passage for both rope and chain. Position the upper section, inserting the gasket between the deck and the base and connect the lower section to the assembly, inserting the shaft into the reduction unit. Fix the windlass by screwing the nuts onto the fixing studs. Connect the supply cables from the windlass to the contactor unit.

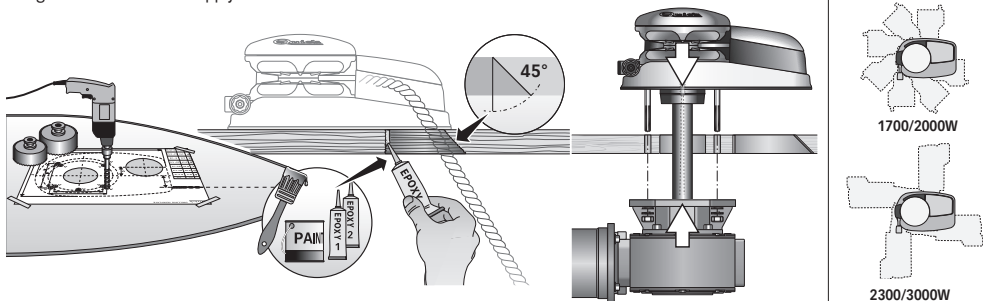

⚠ WARNING: before wiring up, be sure the electrical cables are not live.



BASIC SYSTEM DV5 1700-2000-2300W

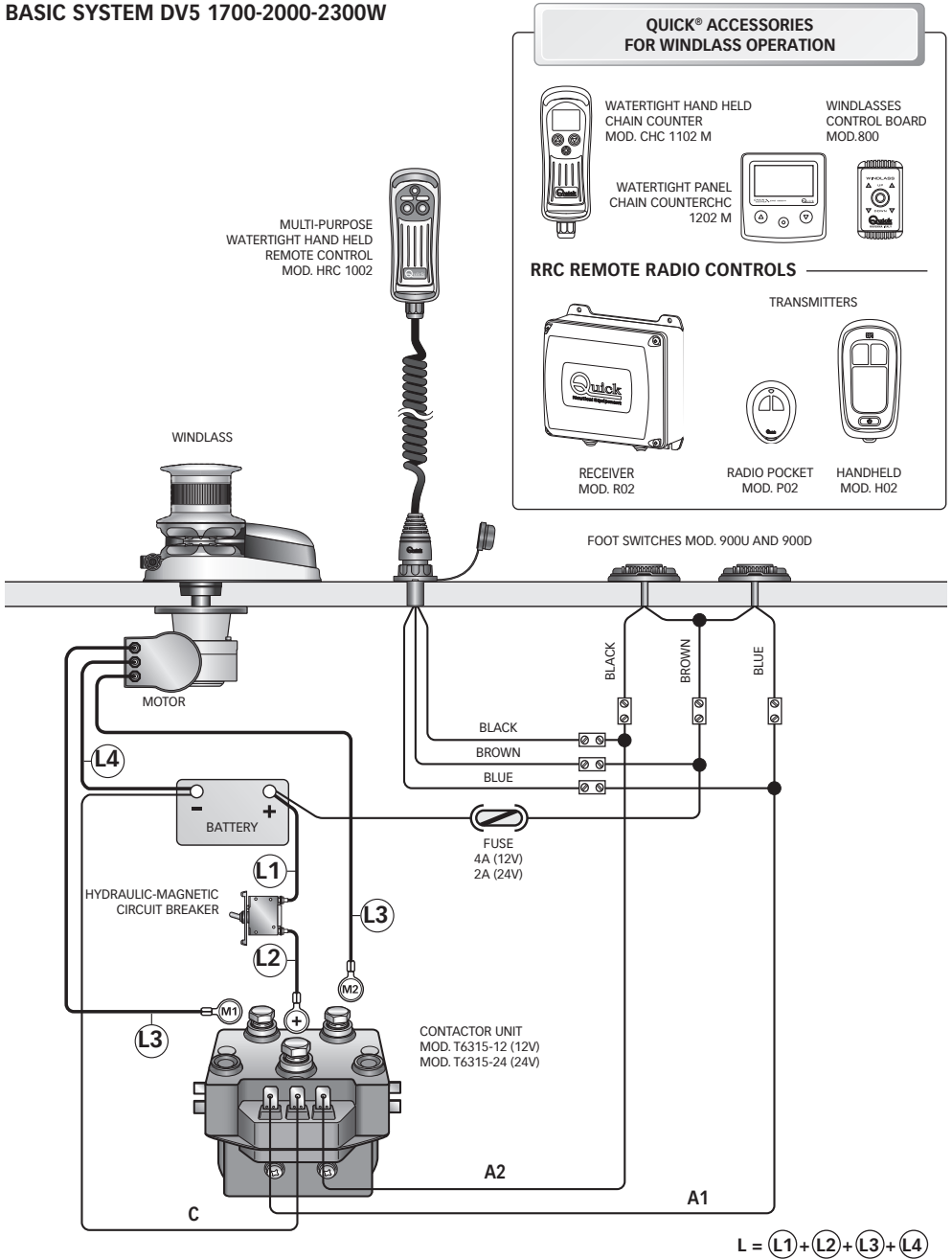



BASIC SYSTEM DV5 3000W

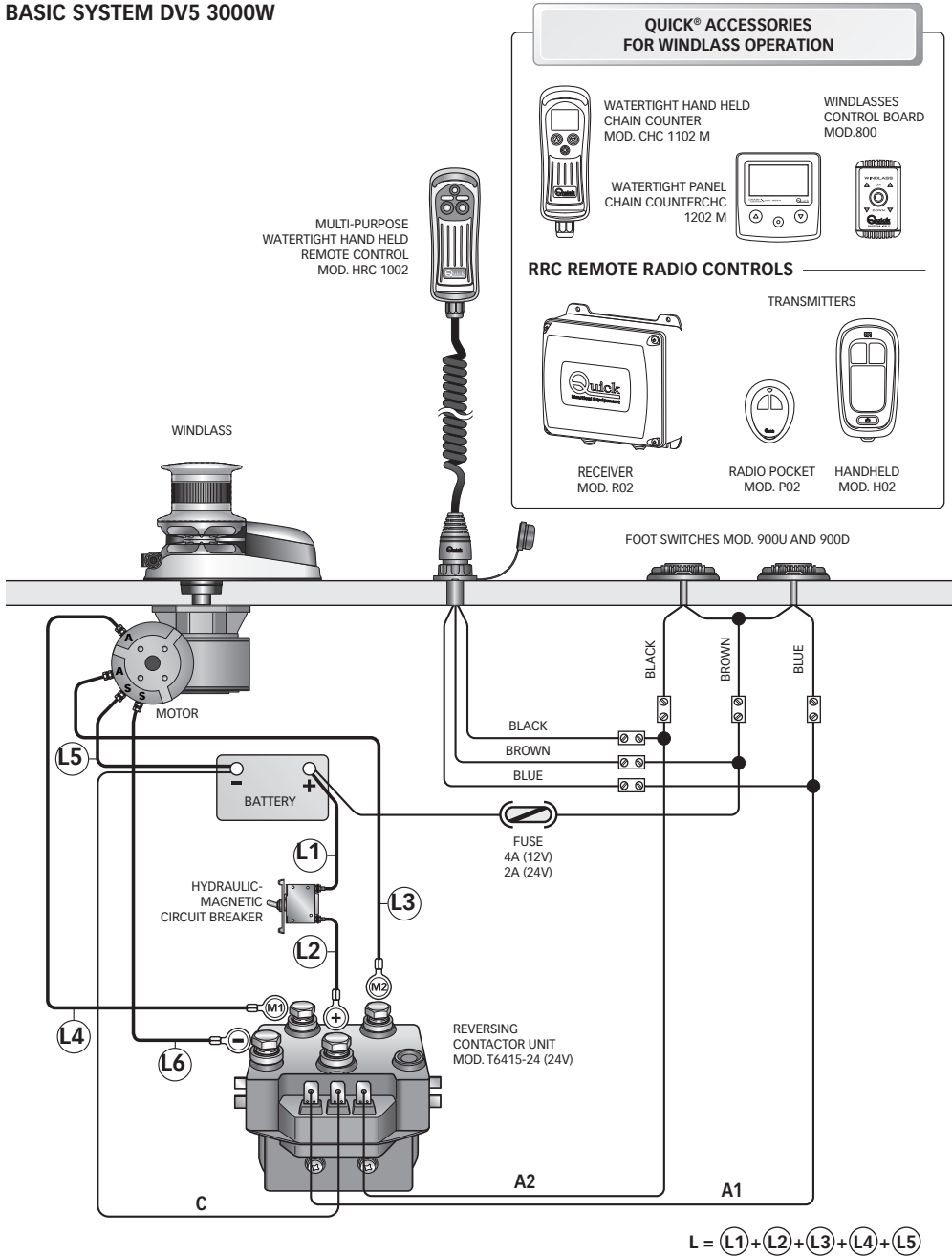



BASIC SYSTEM DV5 3000W 230V

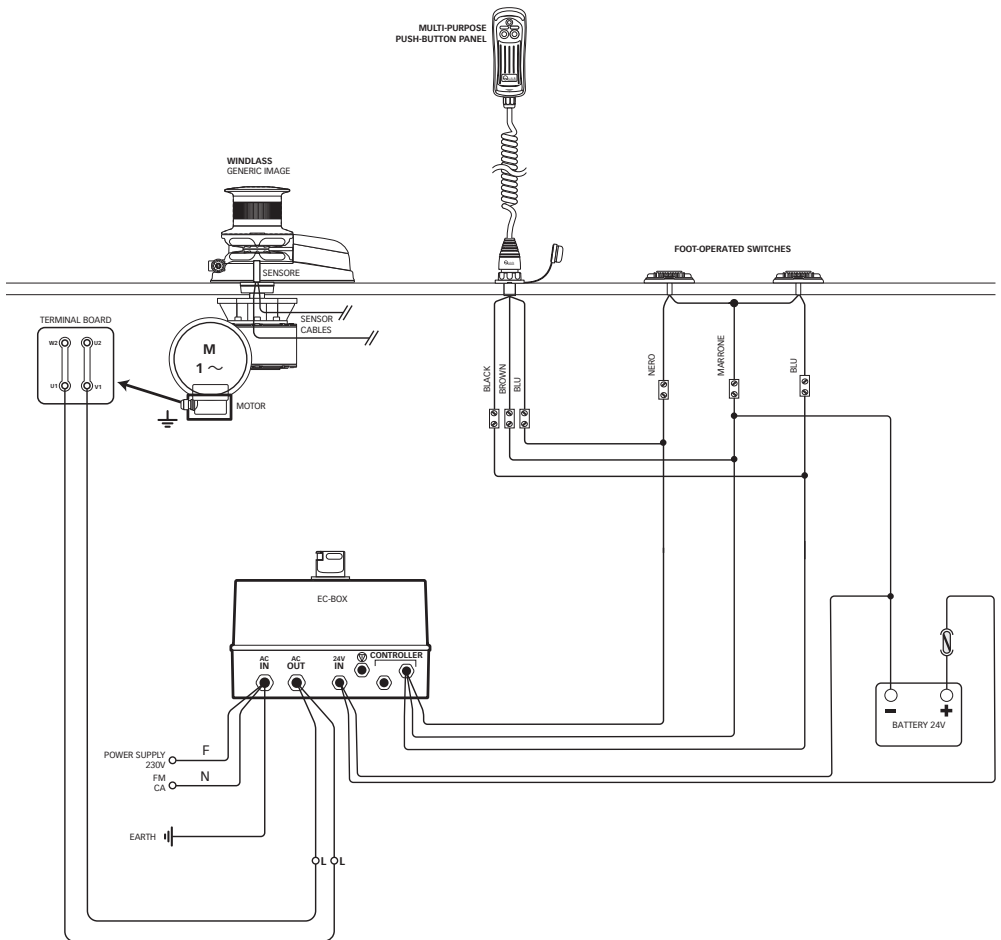



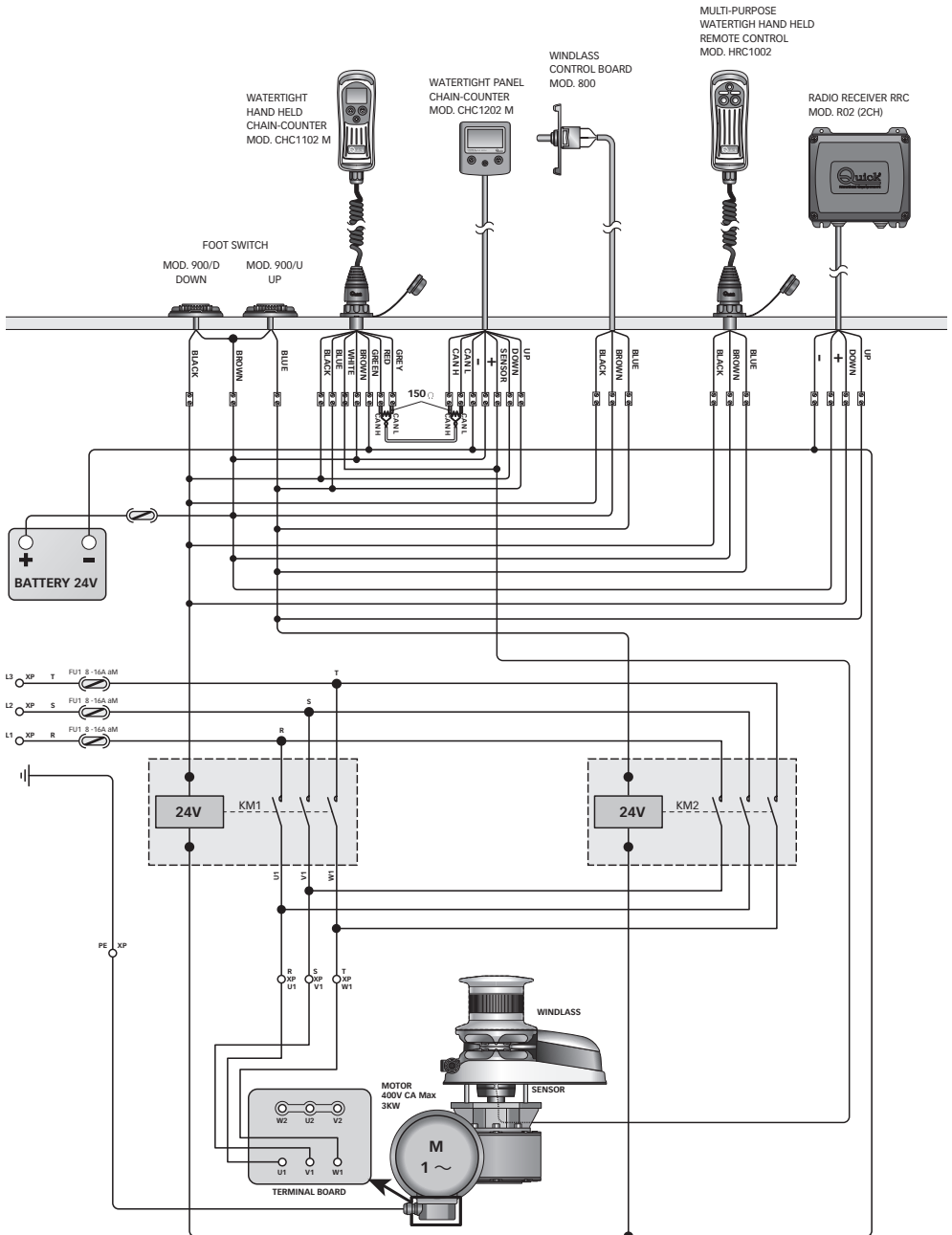

BASIC SYSTEM DV5 3000W 400V





 **WARNING:** stay clear of the chains, ropes and gypsy. Make sure the electric motor is off when windlass is used manually (even when using the handle to disengage the clutch). In fact people with windlass remote controls (hand-held remote control or radio-controlled systems) might accidentally operate it.

 **WARNING:** secure the chain with a device before starting the navigation.

 **WARNING:** do not operate the windlass by using the electrical power when the handle is inserted in the drum or into the gypsy cover.

 **WARNING:** Quick® suggests the use of a protection such as a fuse/thermal-magnetic/ hydraulic-magnetic circuit breaker of suitable power according to the motor chosen, in order to protect it from any overheating or short circuits. The circuit breaker can be used to cut off power to the windlass control circuit and so avoid accidental activation.

CLUTCH USE

The clutch (7 and 9) provides a link between the gypsy and the main shaft (27, 28, 29 or 30).

The clutch can be released (disengagement) by using the handle (1) which, when inserted in the bush (3) of the drum (4) or of the gypsy cover (5), must be turned counter-clockwise. The clutch will be re-engaged by turning it clockwise (engagement).

WEIGHING THE ANCHOR - Turn on the engine. Make sure the clutch is engaged and the brake is released, remove the handle. Press the UP button on the control provided. If the windlass stops and the hydraulic magnetic switch (or thermal cutout) has not tripped, wait a few seconds and try again (avoid keeping the button pressed). If the hydraulic magnetic switch, has tripped, reset it and wait a few minutes before weighing anchor once again. If, after a number of attempts, the windlass is still blocked, we suggest to move the boat to release the anchor. Check the upward movement of the chain for the last few meters in order to avoid damages to the bow.

CASTING THE ANCHOR - The anchor can be cast by using the electrical control or manually. To operate manually, the clutch must be disengaged and the brake is released allowing the gypsy to revolve and letting the rope or chain fall into the water. To slow down the chain, the handle must be turned clockwise. To cast the anchor by using the electrical power, press the DOWN button on the control provided. In this manner, anchor casting is under control and the chain and rope unwind evenly. In order to avoid any stress on the windlass -once the boat is anchored- fasten the chain or secure it in place with a rope.

DRUM USE

WARNING: Before carrying out warping operations, check that the anchor and relative rope or chain are solidly fixed to a bitt or another strong point on the boat.

For the independent use of the drum (4), operate on the brake to lock the gypsy (8). Release the clutch with the handle (1), (at least 2 turns of the bush anticlockwise). Remove the handle from the bush (3), wrap the rope around the drum (2 turns). Activate the windlass control, keeping the rope under tension during take up. By varying the tension during take up it is possible to modify the rope winding speed.



WARNING: during take up maintain a safe distance between hands and windlass drum.

Once take up is complete, screw up the clutch by tightening the gypsy drum clockwise and secure the rope to a bitt or other strong point on the boat.

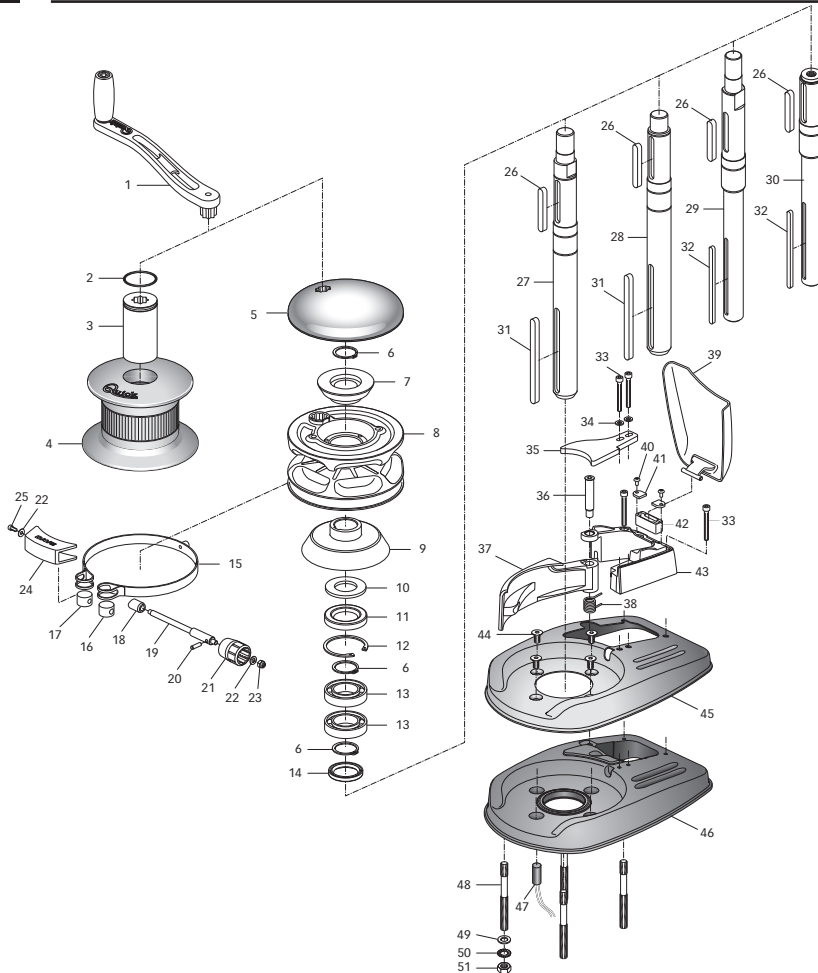

WARNING: make sure the electrical power to the motor is switched off when working manually on the windlass. Carefully remove the chain or rope from the gypsy or the rope from the drum.

Quick® windlasses are manufactured with materials resistant to marine environments. In any case, any salt deposits on the outside must be removed periodically to avoid corrosion and damage to the equipment.

The parts where salt may have built up should be washed thoroughly with fresh water.

Once a year, the drum and the gypsy are to be taken apart as follows:

DRUM VERSION

Use the handle (1) to loosen the bush (3); pull off the drum (4) and the top clutch cone (7); loosen the fixing screws (33) of the rope/chain stripper (35) and remove it. Pull off the gypsy (8).

NO-DRUM VERSION

Use the handle (1) to remove the gypsy cover (5); remove the top clutch cone (7); loosen the fixing screws (33) of the rope/chain stripper (35) and remove it. Pull off the gypsy (8).

Clean all the parts removed to avoid corrosion, and grease the shaft thread (27,28,29 or 30) and the gypsy (8) where the clutch cones rest (7 and 9) (use grease suitable for marine environment).

Remove any oxide deposits from the terminals of the electric motor and the solenoid unit / reversing solenoid; grease them.

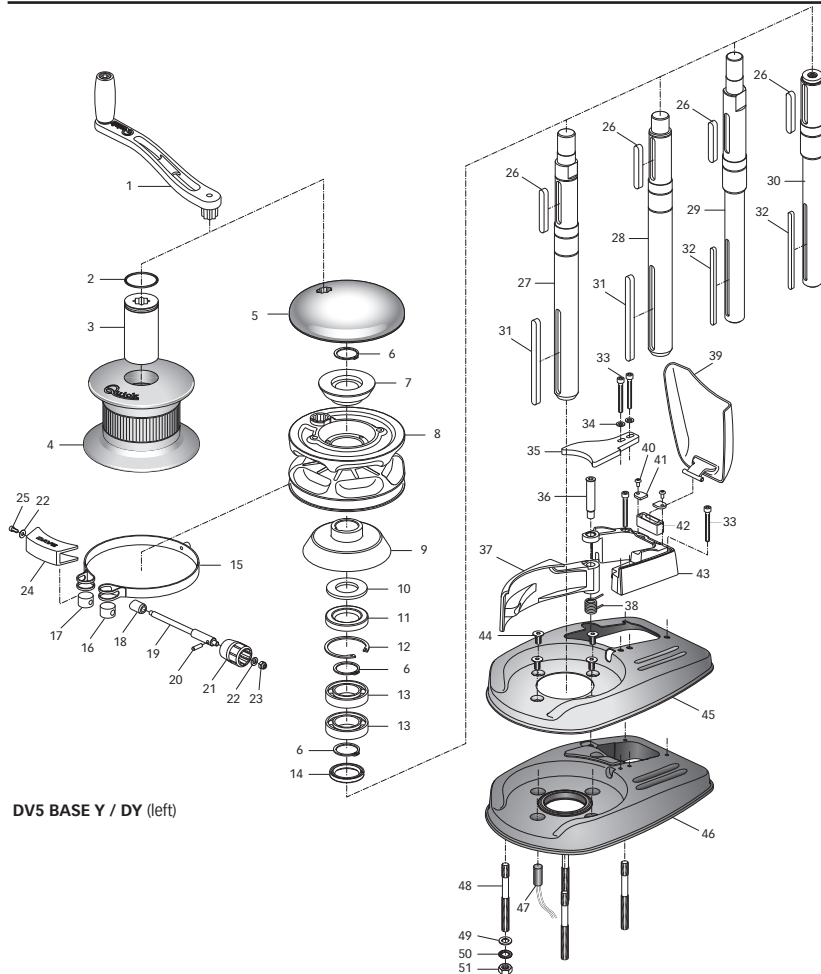

DV5 BASE Y / DY (left)

POS.	DESCRIPTION	19	BRAKE BELT SHAFT "DV" 4000W	38A	SPRING FOR PRESSURE LEVER 3000W "DV" X
1	BENT ANCHOR WINCH LEVER	20	PLUG	38B	SPRING FOR PRESSURE LEVER 3000W "DV" Y
2	O-RING BUSH	21	BRAKE BELT KNOB "DV" SERIES	39A	CHAIN GUIDE COVER "DV" X
3	DRUM BUSH	22	SCREW	39B	CHAIN GUIDE COVER "DV" Y
4	WINDLASS DRUM 2000W	23	SELF-LOCKING NUTS	40	SCREW
5	GYPSY COVER	24	BRAKE BELT CASING "DV"	41	INSERT FOR CHAIN GUIDE "DV"
6	EXTERNAL CIRCLIP	25	SCREW	42	PLASTIC INSERT CHAIN FALL 3000W "DV"
7	TOP CLUTCH CONE 3000W	26	KEY	43A	"DV" CHAIN GUIDE SUPPORT X
8A	GYPSY 3000W 10 MM-3/8" COMPL.	27	SHAFT SERIES "DV" 3000W D	43B	"DV" CHAIN GUIDE SUPPORT Y
8B	GYPSY 3000W 12-13 MM COMPL.	28	SHAFT SERIES "DV" 3000W	44	SCREW
8C	GYPSY 3000W 14MM COMPL.	29	SHAFT SERIES "DV" 1700W D	45A	COVER BASE "DV" INOX X
9	BOTTOM CLUTCH CONE 3000W	30	SHAFT SERIES "DV" 1700W	45B	COVER BASE "DV" INOX Y
10	REINFORCEMENT WASHER 3000W	31	KEY	46A	WINDLASS BASE SERIES "DV" X
11	OIL SEAL	32	KEY	46B	WINDLASS BASE SERIES "DV" Y
12	INTERNAL CIRCLIP	33	SCREW	47	ASSEMBLED SENSOR REED
13	BEARING	34	SCREW	48	STUD
14	OIL SEAL	35	ROPE/CHAIN STRIPPER 4000W "DV"	49	WASHER
15	BRAKE BELT 4000 W "DV"	36	PRESSURE LEVER PIN 3000W "DV"	50	GROWER
16	BRAKE BELT BRASS PIN 3000W	37A	PRESSURE LEVER "DV" X	51	NUT
17	BRAKE BELT BRASS PIN	37B	PRESSURE LEVER "DV" Y		
18	SHAFT INSERT BRAKE BELT "DV"				



MOTORGearBOX 1700W

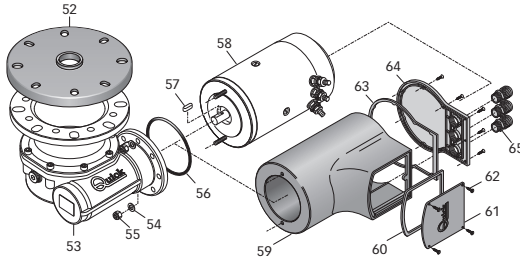

POS.	DESCRIPTION
52	GEARBOX FLANGE GASKET TOP TG70
53	GEARBOX - 1700W - QUICK SERIES
54	WASHER
55	SELF LOCKING NUT
56	O-RING MOTORGearBOX 1700W
57	KEY
58 A	ELECTRIC MOTOR 1700W 12V
58 B	ELECTRIC MOTOR 1700W 24V
59	MOTOR CASING WATERTIGHT 1700W
60	GROMMET
61	TERMINAL BOARD COVER
62	SCREW
63	BOTTOM GASKET
64	BOTTOM PROTEC COVER
65	CABLE OUTLET
66	GEARBOX 2000W
67	WASHER
68	SCREW
69	O-RING 2000W
70	KEY
71	ELECTRIC MOTOR 2000W - 24V
72	MOTOR CASING WATERTIGHT 2000W
73	BOTTOM COVER O-RING
74	BOTTOM PROTEC COVER
75	LOWER TERMINAL BOARD GASKET
76	UPPER TERMINAL BOARD GASKET
77	UPPER TERMINAL BOARD COVER
78	SELF-TAPPING SCREW
79	SELF-TAPPING SCREW
80	GEARBOX 3000W - 24V
81	MOTORGearBOX GASKET 3000W
82	ADAPTATOR 2300W
83	KEY ADAPTATOR 8X7X30
84	ELECTRIC MOTOR 2300W 24V
85	ELECTRIC MOTOR 3000W 24V
86	KEY
87	ELECTRIC MOTOR 4000W AC 230/400

MOTORGearBOX 2000W

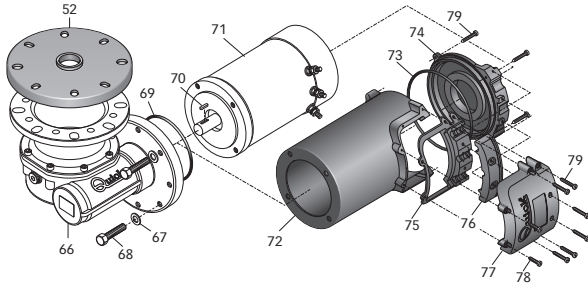

MOTORGearBOX 2300W

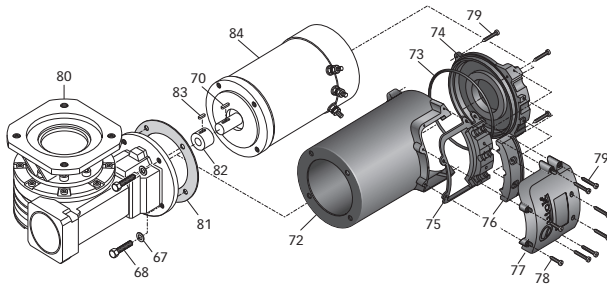

MOTORGearBOX 3000W

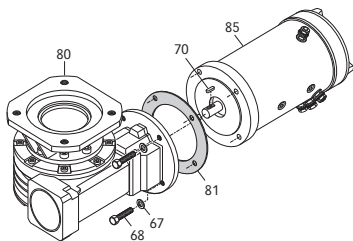

MOTORGearBOX 3000 TR

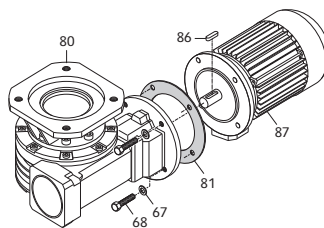

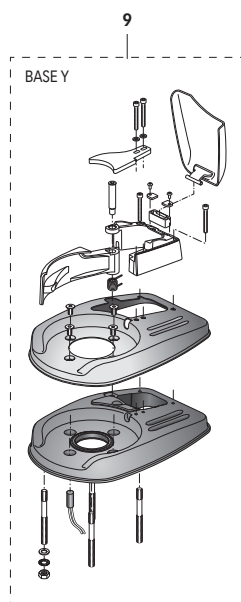
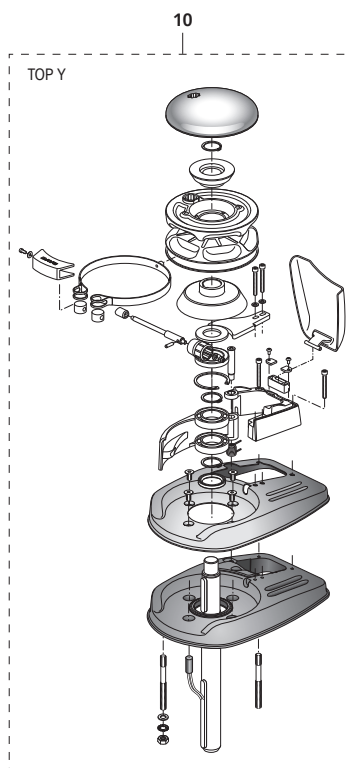
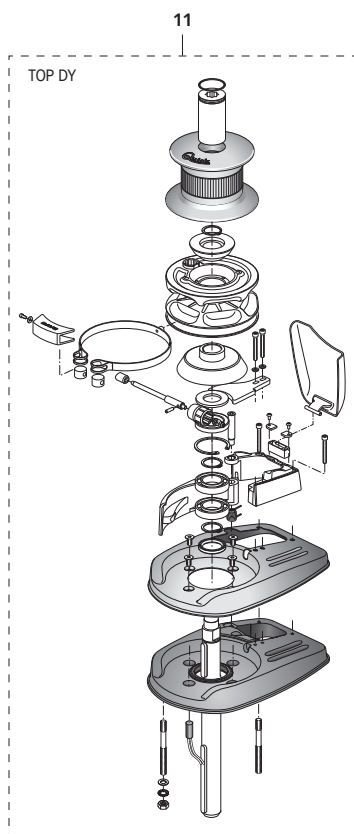
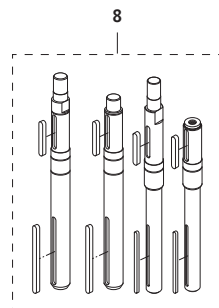
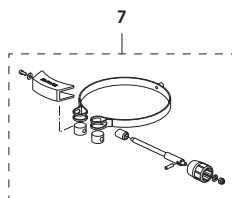
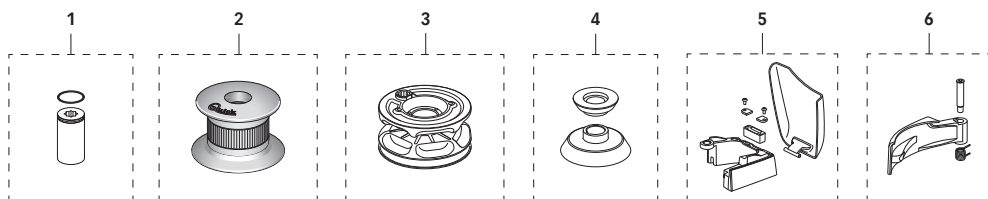



1	OSP DRUM BUSH SERIES DV5	FVSSGMSDCPAG300	10A	OSP TOP DV5 17/2000W X	10MM	FVSSTDVX17010A0
2	OSP DRUM WINDLASS 3000W HR5/DV5/RG5/TB5	FVSSMSE30AG0A00	10B	OSP TOP DV5 17/2000W X	12-13MM	FVSSTDVX17012A0
3A	OSP GYPSY 3000W 10MM-3/8" DV5	FVSSB3010382A00	10C	OSP TOP DV5 17/2000W X	14MM	FVSSTDVX17014A0
3B	OSP GYPSY 3000W 12MM-13MM DV5	FVSSB3012132A00	10D	OSP TOP DV5 17/2000W Y	10MM	FVSSTDVY17010A0
3C	OSP GYPSY 3000W 14MM DV5	FVSSB3014002A00	10E	OSP TOP DV5 17/2000W Y	12-13MM	FVSSTDVY17012A0
4	OSP KIT TOP CLUTCH CONES 3000W DV5/RG5	FVSSCF30DV00A00	10F	OSP TOP DV5 17/2000W Y	14MM	FVSSTDVY17014A0
5A	OSP KIT CHAIN GUIDE COVER DV5 X	FVSSPCSDVX0A00	11A	OSP TOP DV5 17/2000W DX	10MM	FVSSTDVX17D10A0
5B	OSP KIT CHAIN GUIDE COVER DV5 Y	FVSSPCSDVY0A00	11B	OSP TOP DV5 17/2000W DX	12-13MM	FVSSTDVX17D12A0
6A	OSP KIT PRESSURE LEVER DV5 X	FVSSCTDVX000A00	11C	OSP TOP DV5 17/2000W DX	14MM	FVSSTDVX17D14A0
6B	OSP KIT PRESSURE LEVER DV5 Y	FVSSCTDVY000A00	11D	OSP TOP DV5 17/2000W DY	10MM	FVSSTDVY17D10A0
7	OSP KIT STAINLESS STEEL BRAKE BELT DV5	FVSSFRDVX000A00	11E	OSP TOP DV5 17/2000W DY	12-13MM	FVSSTDVY17D12A0
8A	OSP KIT SHAFT DV5 1700	FVSSADV17000A00	11F	OSP TOP DV5 17/2000W DY	14MM	FVSSTDVY17D14A0
8B	OSP KIT SHAFT DV5 1700 D	FVSSADV1700DA00	10A	OSP TOP DV5 3000W X	10MM	FVSSTDVX30010A0
8C	OSP KIT SHAFT DV5 3000	FVSSADV30000A00	10B	OSP TOP DV5 3000W X	12-13MM	FVSSTDVX30012A0
8D	OSP KIT SHAFT DV5 3000 D	FVSSADV3000DA00	10C	OSP TOP DV5 3000W X	14MM	FVSSTDVX30014A0
9A	OSP WINDLASS BASE SERIES DV5 X	FVSSBDV5X000A00	10D	OSP TOP DV5 3000W Y	10MM	FVSSTDVY30010A0
9B	OSP WINDLASS BASE SERIES DV5 Y	FVSSBDV5Y000A00	10E	OSP TOP DV5 3000W Y	12-13MM	FVSSTDVY30012A0
			10F	OSP TOP DV5 3000W Y	14MM	FVSSTDVY30014A0
			11A	OSP TOP DV5 3000W DX	10MM	FVSSTDVX30D10A0
			11B	OSP TOP DV5 3000W DX	12-13MM	FVSSTDVX30D12A0
			11C	OSP TOP DV5 3000W DX	14MM	FVSSTDVX30D14A0
			11D	OSP TOP DV5 3000W DY	10MM	FVSSTDVY30D10A0
			11E	OSP TOP DV5 3000W DY	12-13MM	FVSSTDVY30D12A0
			11F	OSP TOP DV5 3000W DY	14MM	FVSSTDVY30D14A0

12A	OSP GEARBOX 2300W SALPA DV5	FVSSMR230000A00
12B	OSP GEARBOX 3000W SALPA DV5/TB6	FVSSMR300000A00
13A	OSP MOTORGEARBOX 2300W 24V DV5	FVSSR2324000A00
13B	OSP MOTORGEARBOX 3000W 230/400V DV5	FVSSR30TRL00A00
13C	OSP MOTORGEARBOX 3000W 24V DV5	FVSSR3024000A00
14A	OSP MOTOR 2300W SALPA DV5	FVSSMR230000A00
14B	OSP MOTOR 3000W SALPA DV5/TB6	FVSSMR300000A00

12

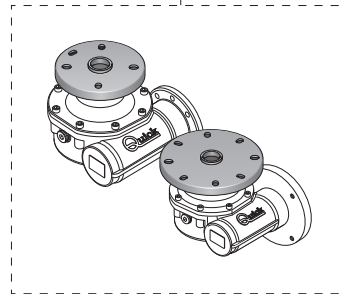

13

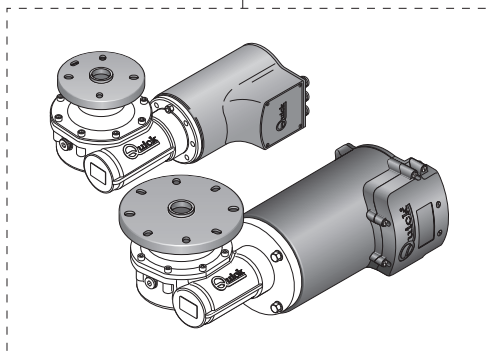

14

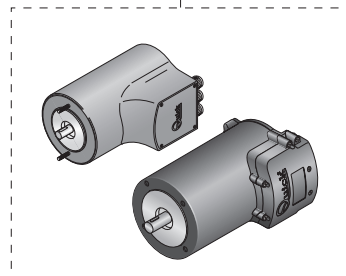



HYDRAULIC MODEL	DV5 HYDRO - / D	
Motor type	Reversible gear-type	
Motor power	9,6 cc	0,59 in ³
Lifting capacity	• 100 bar = 600 kg • 200 bar = 1700 kg	• 1450.4 psi = 1433 lb • 2900 psi = 3748 lb
Max. chain speed @ working load (1)	40 lt /min = 23 mt/min	9,1 USG/min = 76 ft/min
Deck thickness (2)	40 ÷ 80 mm	1" 9/16 ÷ 3" 5/32 inch
Weight - model without drum	31,8 kg	70,1 lb
Weight - model with drum	37 kg	81,6 lb
SETTING VALUES (suggest by Quick)		
Flow rate	40 lt/min	9,1 USG/min
Maximum pression	200 bar	2900 psi

(1) Measurements taken with a gypsy for a 12 mm chain.

(2) On request, shafts and studs can be supplied for greater deck thicknesses.

Model dimensions on page 33

THE PACKAGE CONTAINS: hydraulic windlass (on deck unit + motorgearbox) - drill template - handle - bolts and screws (for assembly) - user's manual - conditions of warranty.

TOOLS REQUIRED FOR INSTALLATION: drill and drill bits: Ø 12 mm (15/32"); Ø 90 mm (3 1/2") hollow mill; hexagonal wrench: 17 mm.

"QUICK" ACCESSORIES RECOMMENDED: anchoring RL control board (mod. 800) - Waterproof hand holds R/C (mod. HRC1002) - Foot switch (mod. 900) - Hydraulic-magnetic circuit breaker - Anchor chain counter (mod. CHC1102M and CHC1202M) - Radio control RRC (mod. R02, P02, H02).

FITTING PROCEDURE

Position the upper section and connect the lower section to the assembly, inserting the shaft into the gearbox.

Fix the windlass by screwing the nuts onto the fixing studs.

Connect the hoses deriving from the selector valve to the flanges of the hydraulic motor (see connection diagram on page 31).

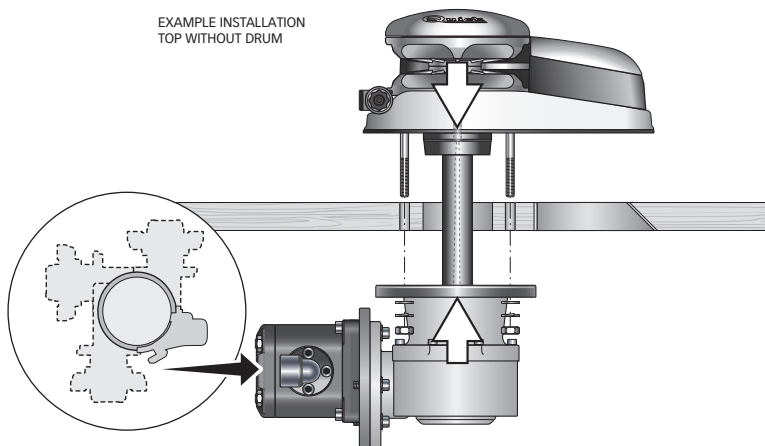



BASIC SYSTEM HYDRAULIC DV5

CONNECTION DIAGRAM

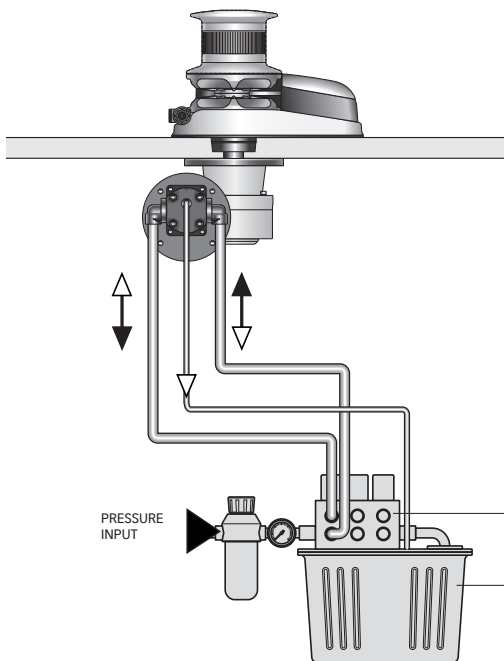

**QUICK® ACCESSORIES
FOR HYDRAULIC WINDLASS OPERATION**

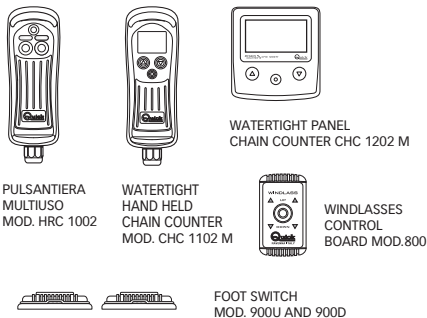

REMOTE RADIO CONTROLS RRC

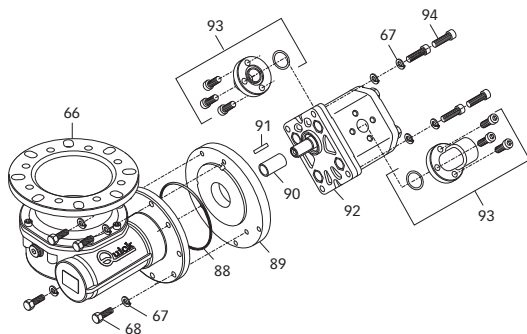
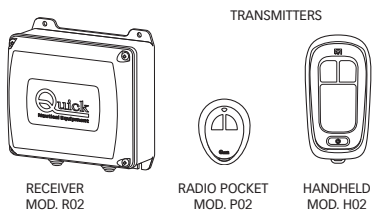

POS.	DESCRIPTION
66	GEARBOX - 2000W - QUICK SERIES
67	SCREW
68	GROWER
87	O-RING
89	FLANGE
90	ADAPTER TG70
91	KEY
92	BIDIRECTIONAL GEAR-TYPE MOTOR 17,9CC
93	FLANGE 90° G3/4 FEMALE
94	SCREW



DV5 1700 Y

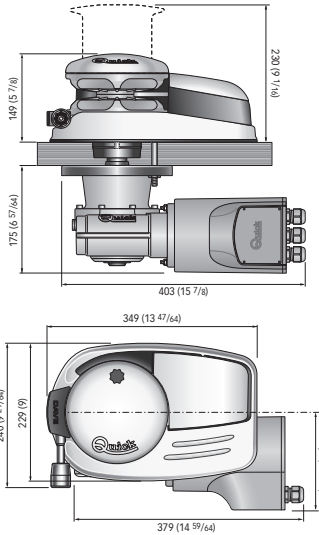

DV5 2000 Y

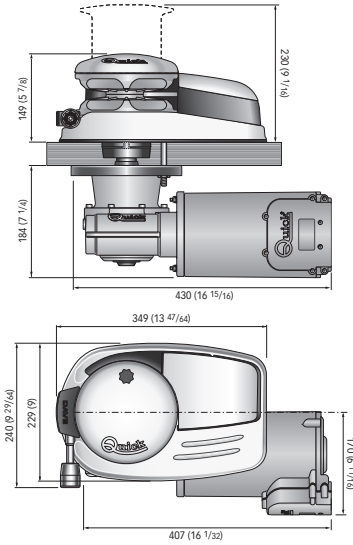

DV5 2300 Y

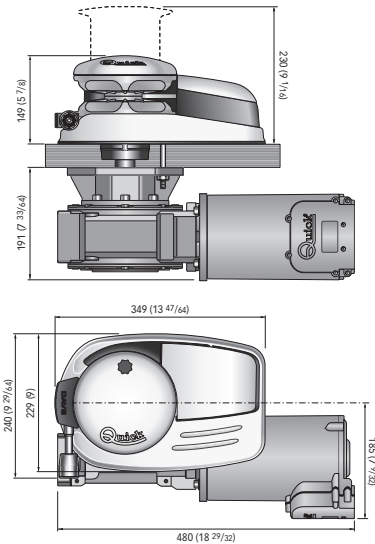

DV5 3000 Y

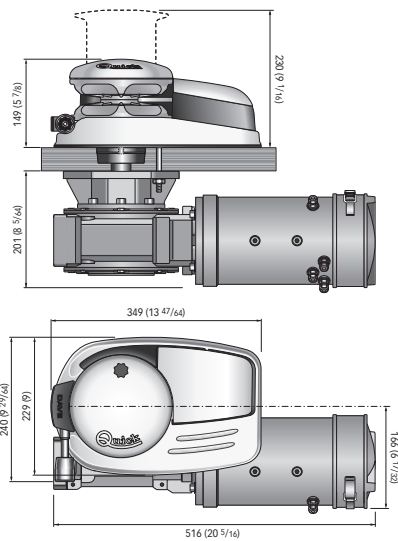



DV5 3000 TR Y

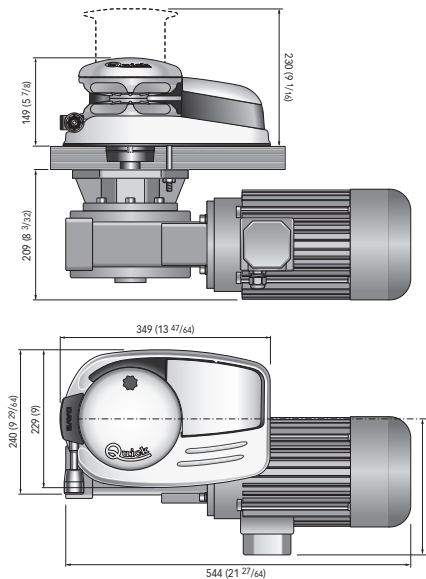

DV5 HYDRO Y

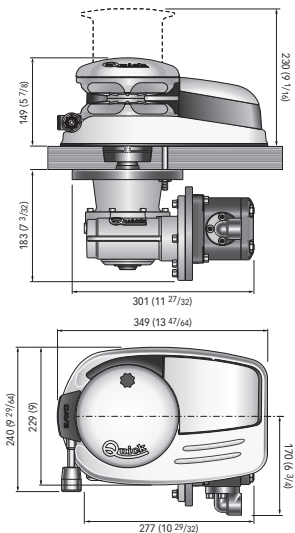

DV5

R003A

1700/2000/2300/3000W
3000TR/HYDRO

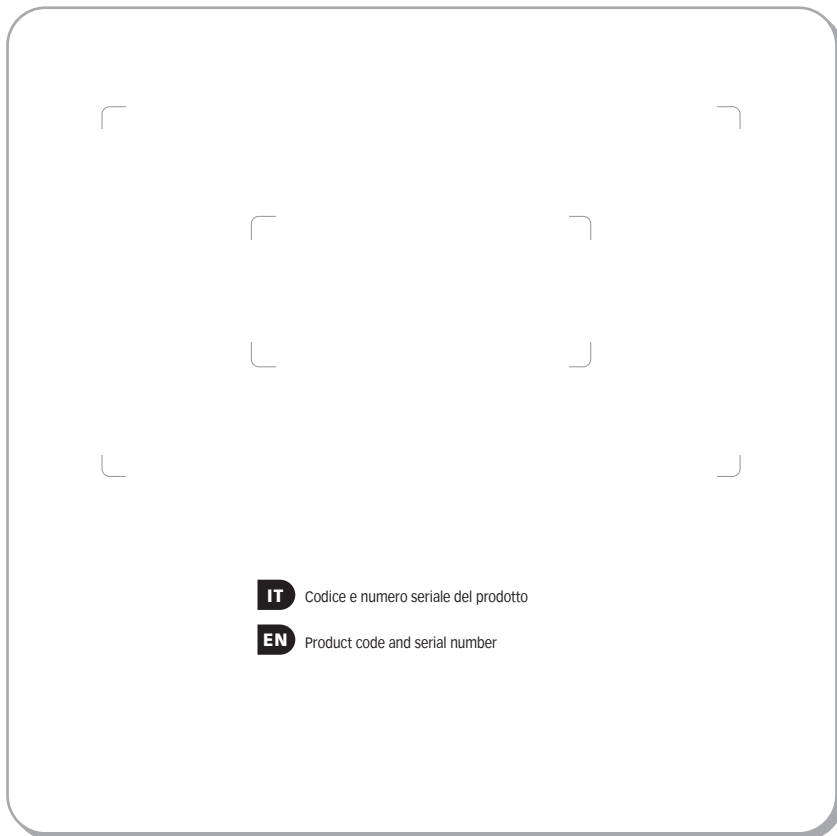

Quick[®]
Nautical Equipment

QUICK[®] S.p.A. - Via Piangipane, 120/A - 48124 Piangipane (RA) - ITALY
Tel. +39.0544.415061 - Fax +39.0544.415047

www.quickitaly.com