

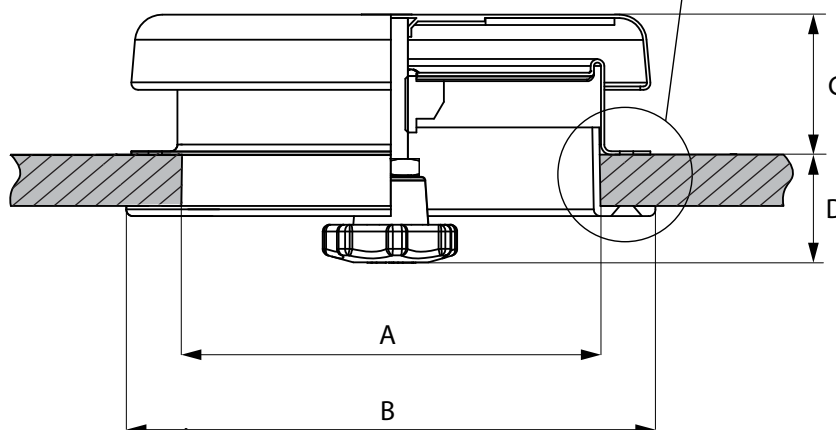

DARTAGN1
ATHOS1
PORTOS1

Dekventilator
Deckventilator
Decksventilator
Aeratuer de pont
Aireadores de cubierta
Ventilatore di coperta

Onderzijde van de flens dient te worden voorzien van een dunne laag siliconenkit.
 The underside of the flange should be coated with a thin layer of silicon sealant.
 Die Unterseite des Flansches muss mit einer dünnen Schicht Silikonkitt versehen werden.
 Il faudra appliquer une fine couche de mastic silicone sur la partie inférieure de la bride.
 La parte inferior del reborde debe cubrirse con una fina capa de sellador de silicona.
 Sul lato inferiore della flangia deve essere applicato un leggero strato di mastice silconico.

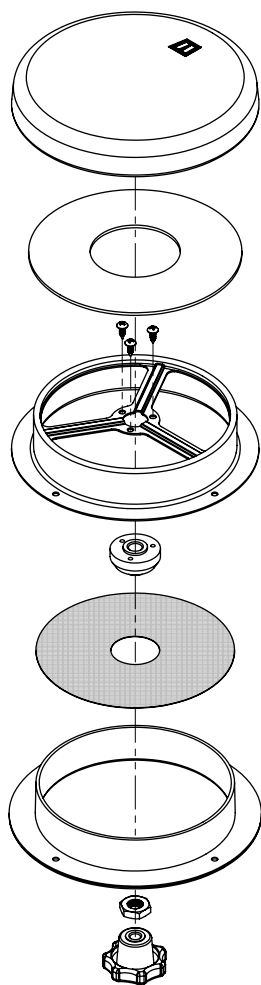
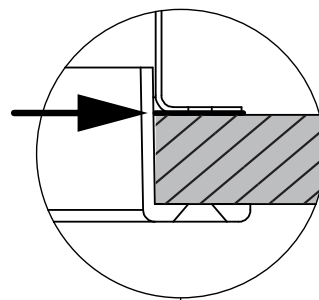

	A	B	C	D
DARTAGN1	Ø 147 (DIA 5 13/16")	Ø 185 (DIA 7 5/16")	36 - 53 (1 7/16" - 2 1/16")	32 - 49 (1 1/4" - 1 15/16")
ATHOS1	Ø 122 (DIA 4 13/16")	Ø 152 (DIA 6")	31 - 43 (1 1/4" - 1 11/16")	37 - 49 (1 7/16" - 1 15/16")
PORTOS1	Ø 85 (DIA 3 3/8")	Ø 117 (DIA 4 5/8")	31 - 45 (1 1/4" - 1 3/4")	27 - 41 (1 1/16" - 1 5/8")

Netto doorlaat - Net opening size - Nettodurchlaß
 Passage net - Conducto neto - Dimensioni retali relative

DARTAGN1	76 cm ² (10.8 sq. inch)
ATHOS1	45 cm ² (7.2 sq. inch)
PORTOS1	30 cm ² (4.7 sq. inch)



FOKKERSTRAAT 571 - 3125 BD SCHIEDAM - HOLLAND
 TEL.: +31 0(0)88 4884700 - sales@vetus.nl - www.vetus.com